

DS26F31MQML Quad High Speed Differential Line Drivers

Check for Samples: [DS26F31MQML](#)

FEATURES

- Operation from Single +5.0V Supply
- Outputs Won't Load Line When $V_{CC} = 0V$
- Output Short Circuit Protection
- Meets the Requirements of EIA Standard RS-422
- High Output Drive Capability for 100 Ω Terminated Transmission Lines

DESCRIPTION

The DS26F31M is a quad differential line driver designed for digital data transmission over balanced lines. The DS26F31M meets all the requirements of EIA Standard RS-422 and Federal Standard 1020. It is designed to provide unipolar differential drive to twisted-pair or parallel-wire transmission lines.

The DS26F31M offers improved performance due to the use of state-of-the-art L-FAST bipolar technology. The L-FAST technology allows for higher speeds and lower currents by utilizing extremely short gate delay times. Thus, the DS26F31M features lower power, extended temperature range, and improved specifications.

The circuit provides an enable and disable function common to all four drivers. The DS26F31M features TRI-STATE outputs and logical OR-ed complementary enable inputs. The inputs are all LS compatible and are all one unit load.

The DS26F31M offers optimum performance when used with the DS26F32 Quad Differential Line Receiver.

Connection and Logic Diagrams

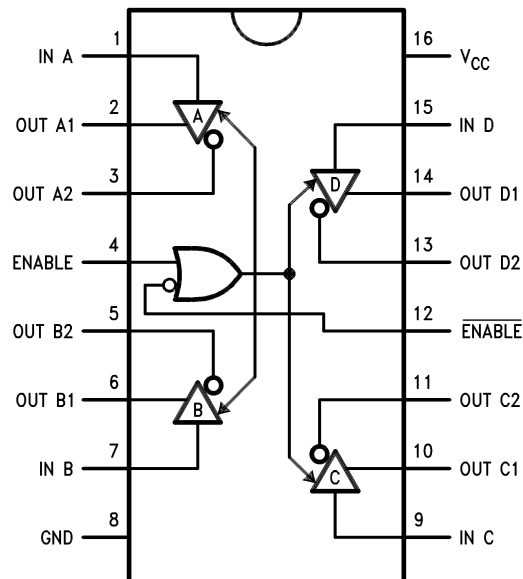

Figure 1. 16-Lead CDIP Package- Top View
See Package Numbers NFE0016A, NAD0016A, NAC0016A



Please be aware that an important notice concerning availability, standard warranty, and use in critical applications of Texas Instruments semiconductor products and disclaimers thereto appears at the end of this data sheet.

All trademarks are the property of their respective owners.

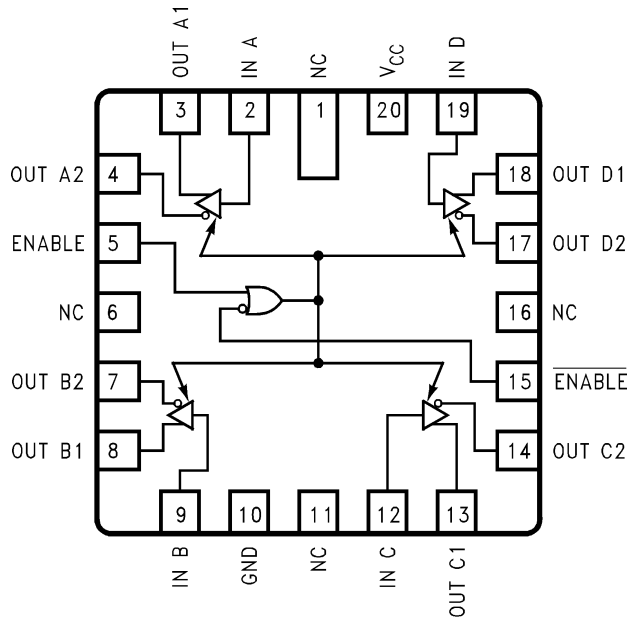

Figure 2. 20-Lead LCCC Package
See Package Number NAJ0020A

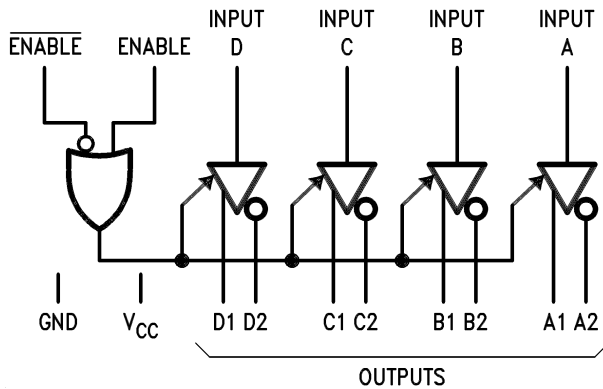

Figure 3. Logic Symbol



These devices have limited built-in ESD protection. The leads should be shorted together or the device placed in conductive foam during storage or handling to prevent electrostatic damage to the MOS gates.

Absolute Maximum Ratings⁽¹⁾

Storage Temperature Range	$-65^{\circ}\text{C} \leq T_A \leq +175^{\circ}\text{C}$
Lead Temperature (Soldering, 60 sec.)	300°C
Supply Voltage	7.0V
Input Voltage	7.0V
Output Voltage	5.5V
Maximum Power Dissipation at 25°C ⁽²⁾	450mW
Thermal Resistance	
θ_{JA}	
NFE0016A, derate above +25°C @ 11.4mW/°C	88°C/mW
NAD0016A, derate above +25°C @ 6.6 mW/°C	151°C/mW
NAJ0020A, derate above +25°C @ 12.3 mW/°C	81°C/mW
θ_{JC}	
NFE0016A	14°C/mW
NAD0016A	13°C/mW
NAJ0020A	15°C/mW

- (1) Absolute Maximum Ratings indicate limits beyond which damage to the device may occur. Operating Ratings indicate conditions for which the device is functional, but do not verify specific performance limits. For verified specifications and test conditions, see the Electrical Characteristics. The verified specifications apply only for the test conditions listed. Some performance characteristics may degrade when the device is not operated under the listed test conditions.
- (2) Power dissipation must be externally controlled at elevated temperatures.

Recommended Operating Range

Temperature	$-55^{\circ}\text{C} \leq T_A \leq +125^{\circ}\text{C}$
Supply Voltage	4.5V to 5.5V

Table 1. Radiation Features

DS26F31MJFQMLV	300 krad (Si)
DS26F31MWFQMLV	300 krad (Si)
DS26F31MWGFQMLV	300 krad (Si)

Quality Conformance Inspection
Table 2. Mil-Std-883, Method 5005 - Group A

Subgroup	Description	Temp °C
1	Static tests at	25
2	Static tests at	125
3	Static tests at	-55
4	Dynamic tests at	25
5	Dynamic tests at	125
6	Dynamic tests at	-55
7	Functional tests at	25
8A	Functional tests at	125
8B	Functional tests at	-55
9	Switching tests at	25
10	Switching tests at	125
11	Switching tests at	-55
12	Settling time at	25
13	Settling time at	125
14	Settling time at	-55

DS26F31M Electrical Characteristics DC Parameters ⁽¹⁾

Parameter		Test Conditions	Notes	Min	Max	Units	Sub-groups
V _{IH}	Logical "1" Input Voltage	V _{CC} = 4.5V	(2)	2.0		V	1, 2, 3
V _{IL}	Logical "0" Input Voltage	V _{CC} = 5.5V	(2)		0.8	V	1, 2, 3
V _{OH}	Logical "1" Output Voltage	V _{CC} = 4.5V, I _{OH} = -20mA, V _{IL} = 0.8V, V _{IH} = 2V		2.5		V	1, 2, 3
V _{OL}	Logical "0" Output Voltage	V _{CC} = 4.5V, I _{OL} = 20mA, V _{IL} = 0.8V, V _{IH} = 2V			0.5	V	1, 2, 3
I _{IH}	Logical "1" Input Current	V _{CC} = 5.5V, V _I = 2.7V	(3)	-2.0	20	μA	1, 2, 3
I _{IL}	Logical "0" Input Current	V _{CC} = 5.5V, V _I = 0.4V	(3)	100	-200	μA	1, 2, 3
I _I	Input Reverse Current	V _{CC} = 5.5V, V _I = 7V	(3)	-0.01	0.1	mA	1, 2, 3
I _{OZ}	TRI-STATE Output Current	V _{CC} = 5.5V, V _O = 0.5V			-20	μA	1, 2, 3
		V _{CC} = 5.5V, V _O = 2.5V			20	μA	1, 2, 3
V _I	Input Clamp Voltage	V _{CC} = 4.5V, I _I = -18mA			-1.5	V	1, 2, 3
I _{SC Min}	Output Short Circuit Current	V _{CC} = 5.5V, V _O = 0V		-30		mA	1, 2, 3
I _{SC Max}	Output Short Circuit Current	V _{CC} = 5.5V, V _O = 0V			-150	mA	1, 2, 3
I _{CC Dis}	Power Supply Current	V _{CC} = 5.5V, V _I = 0.8V or 2V, V _{En} = 0.8V, V _{En} = 2V			50	mA	1, 2, 3
I _{CC En}	Power Supply Current	V _{CC} = 5.5V, V _{En} = 2V, V _{En} = 0.8V			40	mA	1, 2, 3

- (1) Pre and post irradiation limits are identical to those listed under AC and DC electrical characteristics, except as listed in the Post Radiation Limits Table — if applicable. Radiation end point limits for the noted parameters are specified only for the conditions, as specified.
- (2) Parameter tested go-no-go only.
- (3) The minimum limits apply to device Class Q & V. The limits specified for the INPUT LOW CURRENT represents the numerical range in which this parameter will pass.

DS26F31M Electrical Characteristics AC Parameters - Propagation Delay Time

The following conditions apply, unless otherwise specified.

AC: V_{CC} = 5V, C_L = 50pF or equivalent impedance provided by diode load

Parameter		Test Conditions	Notes	Min	Max	Units	Sub-groups
t _{PLH}	Input to Output		(1)		16	nS	9
			(1)		24	nS	10, 11
		C _L = 30pF	(2)		15	nS	9
			(2)		23	nS	10, 11
t _{PHL}	Input to Output		(1)		17	nS	9
			(1)		25	nS	10, 11
		C _L = 30pF	(2)		15	nS	9
			(2)		23	nS	10, 11
t _{LZ}	Disable Time		(1)		38	nS	9
			(1)		56	nS	10, 11
		C _L = 10 pF	(2)		35	nS	9
			(2)		53	nS	10, 11
t _{HZ}	Disable Time		(1)		23	nS	9
			(1)		30	nS	10, 11
		C _L = 10 pF	(2)		20	nS	9
			(2)		27	nS	10, 11

- (1) Tested at 50pF, system capacitance exceed 10 and 30pF.
- (2) Testing at 50pF specifies limits at 10 and 30pF.

DS26F31M Electrical Characteristics AC Parameters - Propagation Delay Time (continued)

The following conditions apply, unless otherwise specified.

AC: $V_{CC} = 5V$, $C_L = 50pF$ or equivalent impedance provided by diode load

Parameter		Test Conditions	Notes	Min	Max	Units	Sub-groups
t_{ZL}	Enable Time		(1)		28	nS	9
			(1)		40	nS	10, 11
		$C_L = 30pF$	(2)		25	nS	9
			(2)		37	nS	10, 11
t_{ZH}	Enable Time		(1)		32	nS	9
			(1)		52	nS	10, 11
		$C_L = 30 pF$	(2)		30	nS	9
			(2)		50	nS	10, 11
Skew	Output to Output		(1)		6.0	nS	9
			(1)		9.0	nS	10, 11
		$C_L = 30pF$	(2)		4.5	nS	9
			(2)		7.0	nS	10, 11

DS26F31M Electrical Characteristics DC Drift Parameters

This section applies to -QMLV devices only and shall be read & recorded at $T_A = +25^\circ C$ before and after each burn-in & Subgroup B5, and shall not change by more than the limits indicated. The delta rejects shall be included in the PDA calculations.

Parameter		Test Conditions	Notes	Min	Max	Units	Sub-groups
V_{OH}	Logical "1" Output Voltage	$V_{CC} = 4.5V$, $I_{OH} = -20mA$, $V_{IL} = 0.8V$, $V_{IH} = 2V$.		-250	250	mV	1
V_{OL}	Logical "0" Output Voltage	$V_{CC} = 4.5V$, $I_{OL} = 20mA$, $V_{IL} = 0.8V$, $V_{IH} = 2V$.		-50	50	mV	1
$I_{CC\ En}$	Power Supply Current	$V_{CC} = 5.5V$, $V_I = 0.8V$ or $2V$, $V_{En} = 2V$, $V_{En} = 0.8V$.		-8.0	8.0	mA	1
$I_{CC\ Dis}$	Power Supply Current	$V_{CC} = 5.5V$, $V_I = 0.8V$ or $2V$, $V_{En} = 0.8V$, $V_{En} = 2V$.		-8.0	8.0	mA	1

TEST CIRCUIT AND TIMING WAVEFORMS

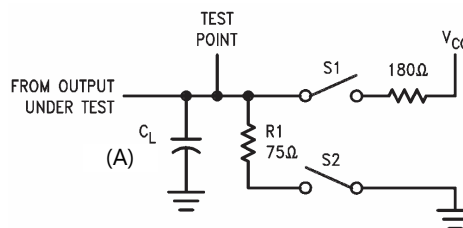

- A. Parameter tested go-no-go only.
S1 and S2 of Load Circuit are closed except where shown.
 C_L includes probe and jig capacitance.

Figure 4. AC Load Test Circuit for TRI-STATE Outputs

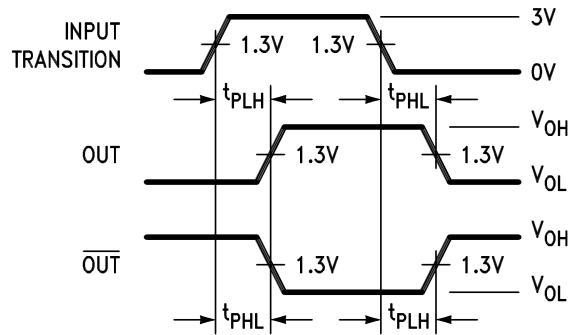

Pulse Generator for all Pulses: Rate $\leq 1.0\text{ MHz}$, $Z_O = 50\Omega$, $t_r \leq 6.0\text{ ns}$, $t_f \leq 6.0\text{ ns}$.

Figure 5. Propagation Delay (1) (2)

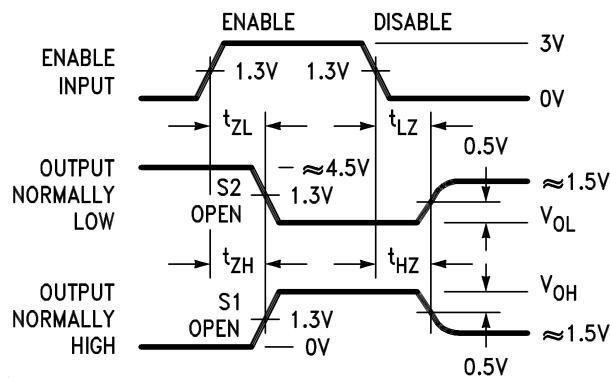

Pulse Generator for all Pulses: Rate $\leq 1.0\text{ MHz}$, $Z_O = 50\Omega$, $t_r \leq 6.0\text{ ns}$, $t_f \leq 6.0\text{ ns}$.

Diagram shown for Enable Low. Switches S1 and S2 open.

Figure 6. Enable and Disable Times (2)

- (1) Absolute Maximum Ratings indicate limits beyond which damage to the device may occur. Operating Ratings indicate conditions for which the device is functional, but do not verify specific performance limits. For verified specifications and test conditions, see the Electrical Characteristics. The verified specifications apply only for the test conditions listed. Some performance characteristics may degrade when the device is not operated under the listed test conditions.
- (2) All currents into the device pins are positive; all currents out of the device pins are negative. All voltages are referenced to ground unless otherwise specified.

TYPICAL APPLICATION

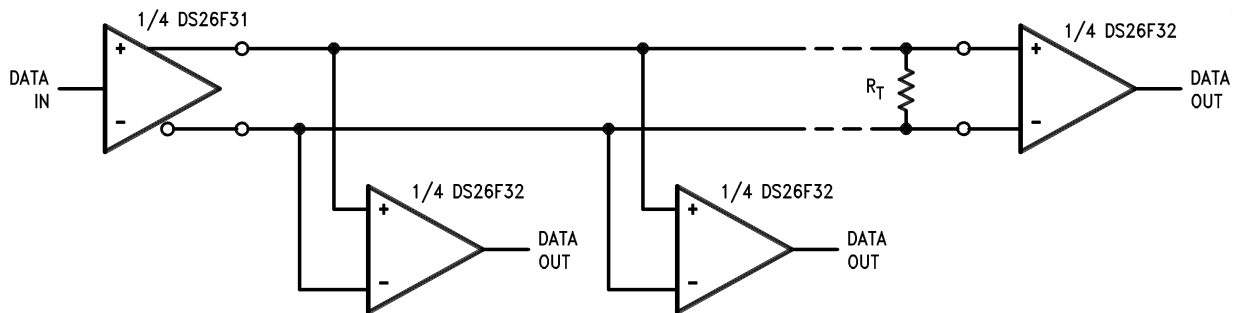

Figure 7. Typical Application

REVISION HISTORY

Released	Revision	Section	Originator	Changes
3/01/06	*	New Release, Corporate format	L. Lytle	1 MDS data sheet converted into one Corp. data sheet format. MNDS26F31M-X-RH Rev 0B0 will be archived.
4/15/2013	A			Changed layout of National Data Sheet to TI format

PACKAGING INFORMATION

Orderable Device	Status (1)	Package Type	Package Drawing	Pins	Package Qty	Eco Plan (2)	Lead/Ball Finish (6)	MSL Peak Temp (3)	Op Temp (°C)	Device Marking (4/5)	Samples
5962-7802302M2A	ACTIVE	LCCC	NAJ	20	50	TBD	Call TI	Call TI	-55 to 125	DS26F31ME/ 883 Q 5962-78023 02M2A ACO 02M2A >T	Samples
5962-7802302MFA	ACTIVE	CFP	NAD	16	19	TBD	Call TI	Call TI	-55 to 125	DS26F31MW /883 Q 5962-78023 02MFA ACO 02MFA >T	Samples
5962F7802302VFA	ACTIVE	CFP	NAD	16	19	TBD	Call TI	Call TI	-55 to 125	DS26F31MWF QMLV Q 5962F78023 02VFA ACO 02VFA >T	Samples
DS26F31ME/883	ACTIVE	LCCC	NAJ	20	50	TBD	Call TI	Call TI	-55 to 125	DS26F31ME/ 883 Q 5962-78023 02M2A ACO 02M2A >T	Samples
DS26F31MW/883	ACTIVE	CFP	NAD	16	19	TBD	Call TI	Call TI	-55 to 125	DS26F31MW /883 Q 5962-78023 02MFA ACO 02MFA >T	Samples
DS26F31MWFQMLV	ACTIVE	CFP	NAD	16	19	TBD	Call TI	Call TI	-55 to 125	DS26F31MWF QMLV Q 5962F78023 02VFA ACO 02VFA >T	Samples

(1) The marketing status values are defined as follows:

ACTIVE: Product device recommended for new designs.

LIFEBUY: TI has announced that the device will be discontinued, and a lifetime-buy period is in effect.

NRND: Not recommended for new designs. Device is in production to support existing customers, but TI does not recommend using this part in a new design.

PREVIEW: Device has been announced but is not in production. Samples may or may not be available.

OBSOLETE: TI has discontinued the production of the device.

(2) Eco Plan - The planned eco-friendly classification: Pb-Free (RoHS), Pb-Free (RoHS Exempt), or Green (RoHS & no Sb/Br) - please check <http://www.ti.com/productcontent> for the latest availability information and additional product content details.

TBD: The Pb-Free/Green conversion plan has not been defined.

Pb-Free (RoHS): TI's terms "Lead-Free" or "Pb-Free" mean semiconductor products that are compatible with the current RoHS requirements for all 6 substances, including the requirement that lead not exceed 0.1% by weight in homogeneous materials. Where designed to be soldered at high temperatures, TI Pb-Free products are suitable for use in specified lead-free processes.

Pb-Free (RoHS Exempt): This component has a RoHS exemption for either 1) lead-based flip-chip solder bumps used between the die and package, or 2) lead-based die adhesive used between the die and leadframe. The component is otherwise considered Pb-Free (RoHS compatible) as defined above.

Green (RoHS & no Sb/Br): TI defines "Green" to mean Pb-Free (RoHS compatible), and free of Bromine (Br) and Antimony (Sb) based flame retardants (Br or Sb do not exceed 0.1% by weight in homogeneous material)

(3) MSL, Peak Temp. - The Moisture Sensitivity Level rating according to the JEDEC industry standard classifications, and peak solder temperature.

(4) There may be additional marking, which relates to the logo, the lot trace code information, or the environmental category on the device.

(5) Multiple Device Markings will be inside parentheses. Only one Device Marking contained in parentheses and separated by a "~" will appear on a device. If a line is indented then it is a continuation of the previous line and the two combined represent the entire Device Marking for that device.

(6) Lead/Ball Finish - Orderable Devices may have multiple material finish options. Finish options are separated by a vertical ruled line. Lead/Ball Finish values may wrap to two lines if the finish value exceeds the maximum column width.

Important Information and Disclaimer: The information provided on this page represents TI's knowledge and belief as of the date that it is provided. TI bases its knowledge and belief on information provided by third parties, and makes no representation or warranty as to the accuracy of such information. Efforts are underway to better integrate information from third parties. TI has taken and continues to take reasonable steps to provide representative and accurate information but may not have conducted destructive testing or chemical analysis on incoming materials and chemicals. TI and TI suppliers consider certain information to be proprietary, and thus CAS numbers and other limited information may not be available for release.

In no event shall TI's liability arising out of such information exceed the total purchase price of the TI part(s) at issue in this document sold by TI to Customer on an annual basis.

OTHER QUALIFIED VERSIONS OF DS26F31MQML, DS26F31MQML-SP :

- Military: [DS26F31MQML](#)
- Space: [DS26F31MQML-SP](#)

NOTE: Qualified Version Definitions:

- Military - QML certified for Military and Defense Applications
- Space - Radiation tolerant, ceramic packaging and qualified for use in Space-based application

NAD0016A

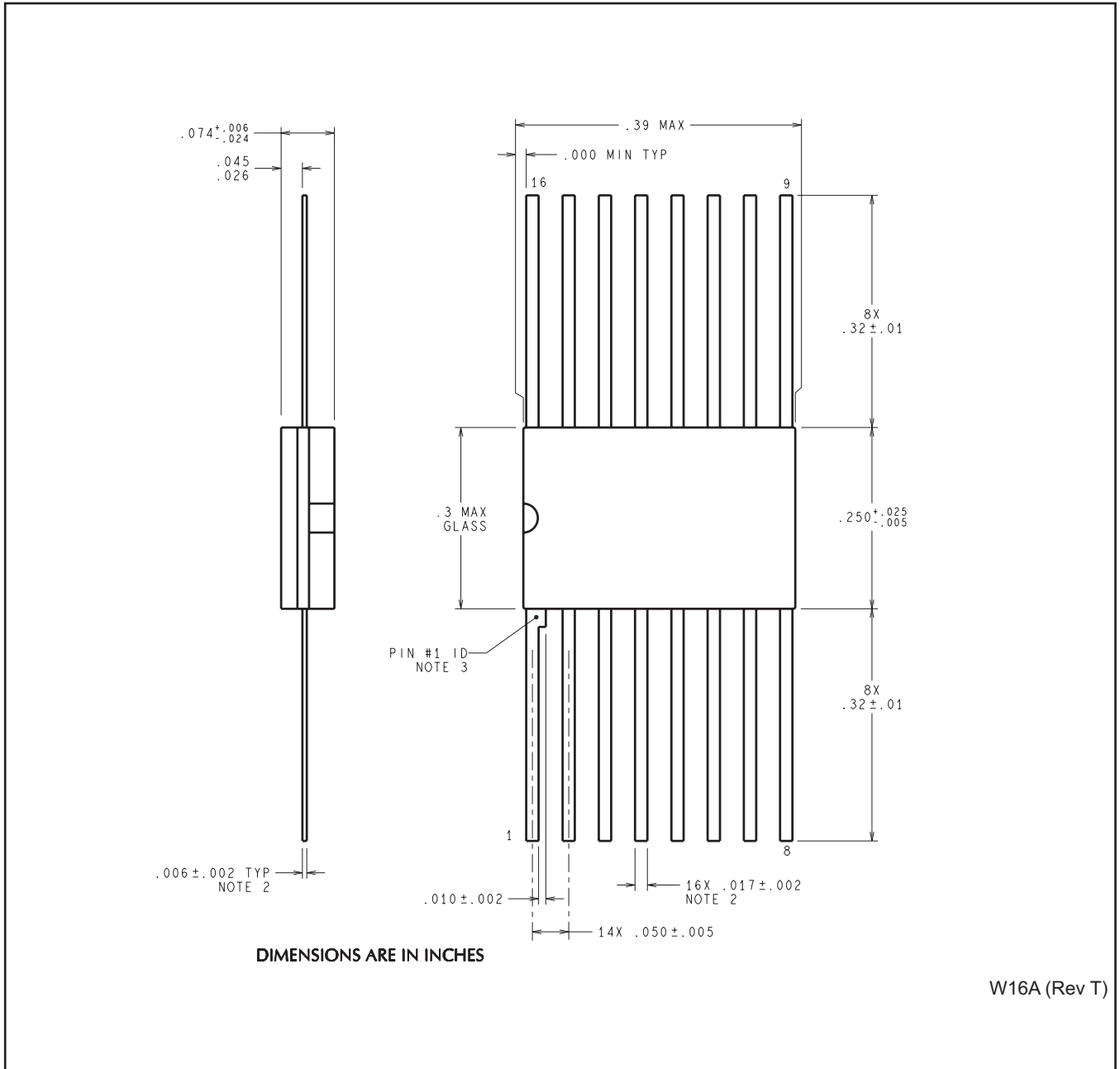

W16A (Rev T)

NAJ0020A

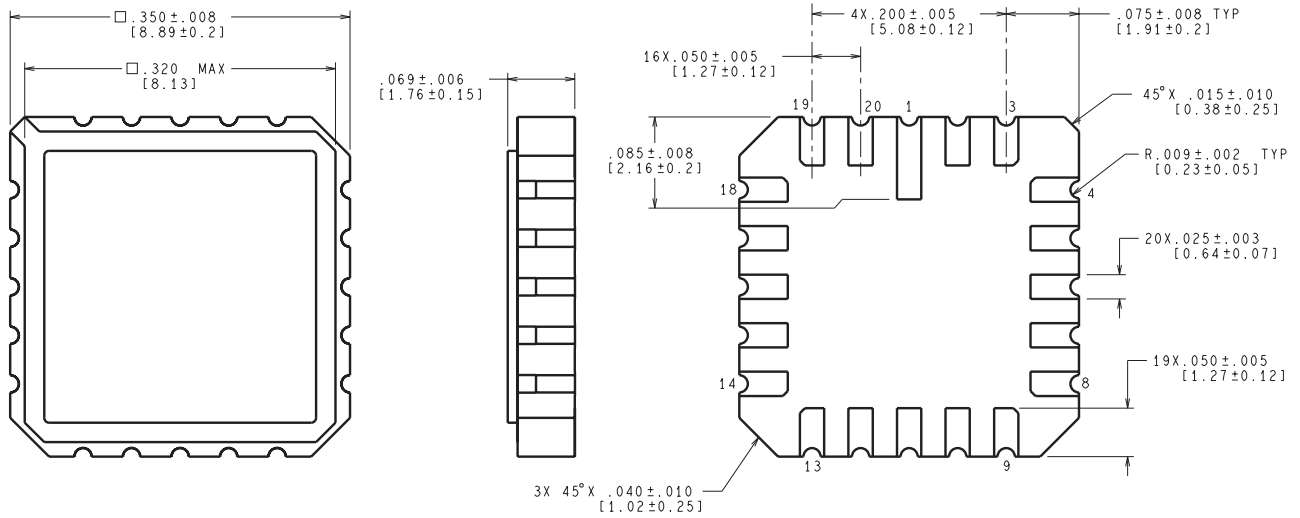

CONTROLLING DIMENSION IS INCH
 VALUES IN [] ARE MILLIMETERS

E20A (Rev F)

IMPORTANT NOTICE

Texas Instruments Incorporated and its subsidiaries (TI) reserve the right to make corrections, enhancements, improvements and other changes to its semiconductor products and services per JESD46, latest issue, and to discontinue any product or service per JESD48, latest issue. Buyers should obtain the latest relevant information before placing orders and should verify that such information is current and complete. All semiconductor products (also referred to herein as "components") are sold subject to TI's terms and conditions of sale supplied at the time of order acknowledgment.

TI warrants performance of its components to the specifications applicable at the time of sale, in accordance with the warranty in TI's terms and conditions of sale of semiconductor products. Testing and other quality control techniques are used to the extent TI deems necessary to support this warranty. Except where mandated by applicable law, testing of all parameters of each component is not necessarily performed.

TI assumes no liability for applications assistance or the design of Buyers' products. Buyers are responsible for their products and applications using TI components. To minimize the risks associated with Buyers' products and applications, Buyers should provide adequate design and operating safeguards.

TI does not warrant or represent that any license, either express or implied, is granted under any patent right, copyright, mask work right, or other intellectual property right relating to any combination, machine, or process in which TI components or services are used. Information published by TI regarding third-party products or services does not constitute a license to use such products or services or a warranty or endorsement thereof. Use of such information may require a license from a third party under the patents or other intellectual property of the third party, or a license from TI under the patents or other intellectual property of TI.

Reproduction of significant portions of TI information in TI data books or data sheets is permissible only if reproduction is without alteration and is accompanied by all associated warranties, conditions, limitations, and notices. TI is not responsible or liable for such altered documentation. Information of third parties may be subject to additional restrictions.

Resale of TI components or services with statements different from or beyond the parameters stated by TI for that component or service voids all express and any implied warranties for the associated TI component or service and is an unfair and deceptive business practice. TI is not responsible or liable for any such statements.

Buyer acknowledges and agrees that it is solely responsible for compliance with all legal, regulatory and safety-related requirements concerning its products, and any use of TI components in its applications, notwithstanding any applications-related information or support that may be provided by TI. Buyer represents and agrees that it has all the necessary expertise to create and implement safeguards which anticipate dangerous consequences of failures, monitor failures and their consequences, lessen the likelihood of failures that might cause harm and take appropriate remedial actions. Buyer will fully indemnify TI and its representatives against any damages arising out of the use of any TI components in safety-critical applications.

In some cases, TI components may be promoted specifically to facilitate safety-related applications. With such components, TI's goal is to help enable customers to design and create their own end-product solutions that meet applicable functional safety standards and requirements. Nonetheless, such components are subject to these terms.

No TI components are authorized for use in FDA Class III (or similar life-critical medical equipment) unless authorized officers of the parties have executed a special agreement specifically governing such use.

Only those TI components which TI has specifically designated as military grade or "enhanced plastic" are designed and intended for use in military/aerospace applications or environments. Buyer acknowledges and agrees that any military or aerospace use of TI components which have **not** been so designated is solely at the Buyer's risk, and that Buyer is solely responsible for compliance with all legal and regulatory requirements in connection with such use.

TI has specifically designated certain components as meeting ISO/TS16949 requirements, mainly for automotive use. In any case of use of non-designated products, TI will not be responsible for any failure to meet ISO/TS16949.

Products

Audio	www.ti.com/audio
Amplifiers	amplifier.ti.com
Data Converters	dataconverter.ti.com
DLP® Products	www.dlp.com
DSP	dsp.ti.com
Clocks and Timers	www.ti.com/clocks
Interface	interface.ti.com
Logic	logic.ti.com
Power Mgmt	power.ti.com
Microcontrollers	microcontroller.ti.com
RFID	www.ti-rfid.com
OMAP Applications Processors	www.ti.com/omap
Wireless Connectivity	www.ti.com/wirelessconnectivity

Applications

Automotive and Transportation	www.ti.com/automotive
Communications and Telecom	www.ti.com/communications
Computers and Peripherals	www.ti.com/computers
Consumer Electronics	www.ti.com/consumer-apps
Energy and Lighting	www.ti.com/energy
Industrial	www.ti.com/industrial
Medical	www.ti.com/medical
Security	www.ti.com/security
Space, Avionics and Defense	www.ti.com/space-avionics-defense
Video and Imaging	www.ti.com/video

TI E2E Community

e2e.ti.com