

DS90LV004 4-Channel LVDS Buffer/Repeater with Pre-Emphasis

 Check for Samples: [DS90LV004](#)

FEATURES

- 1.5 Gbps data rate per channel
- Configurable pre-emphasis drives lossy backplanes and cables
- Low output skew and jitter
- LVDS/CML/LVPECL compatible input, LVDS output
- On-chip 100Ω input and output termination
- 12 kV ESD protection on LVDS outputs
- Single 3.3V supply
- Very low power consumption
- Industrial -40 to +85°C temperature range
- Small TQFP Package Footprint
- Evaluation Kit Available
- See SCAN90004 for JTAG-enabled version

DESCRIPTION

The DS90LV004 is a four channel 1.5 Gbps LVDS buffer/repeater. High speed data paths and flow-through pinout minimize internal device jitter and simplify board layout, while configurable pre-emphasis overcomes ISI jitter effects from lossy backplanes and cables. The differential inputs interface to LVDS, and Bus LVDS signals such as those on TI's 10-, 16-, and 18-bit Bus LVDS SerDes, as well as CML and LVPECL. The differential inputs and outputs are internally terminated with a 100Ω resistor to improve performance and minimize board space. The repeater function is especially useful for boosting signals for longer distance transmission over lossy cables and backplanes.

Typical Application

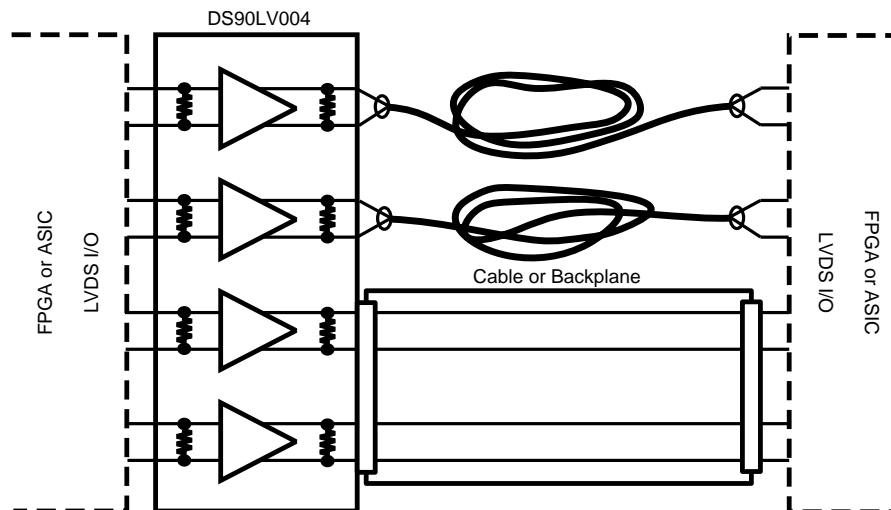

Please be aware that an important notice concerning availability, standard warranty, and use in critical applications of Texas Instruments semiconductor products and disclaimers thereto appears at the end of this data sheet.

TRI-STATE is a registered trademark of National Semiconductor Corporation.
All other trademarks are the property of their respective owners.

Block and Connection Diagrams

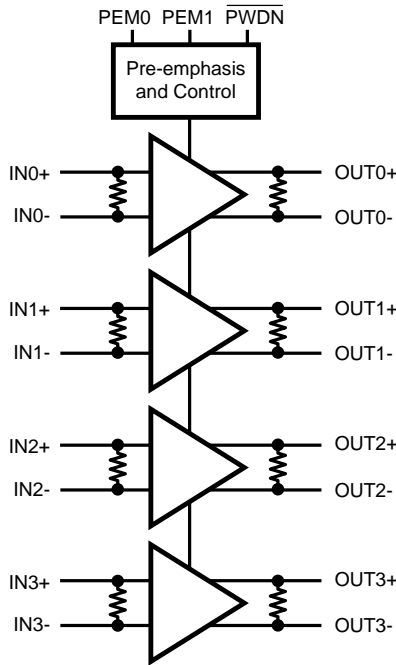

Figure 1. DS90LV004 Block Diagram

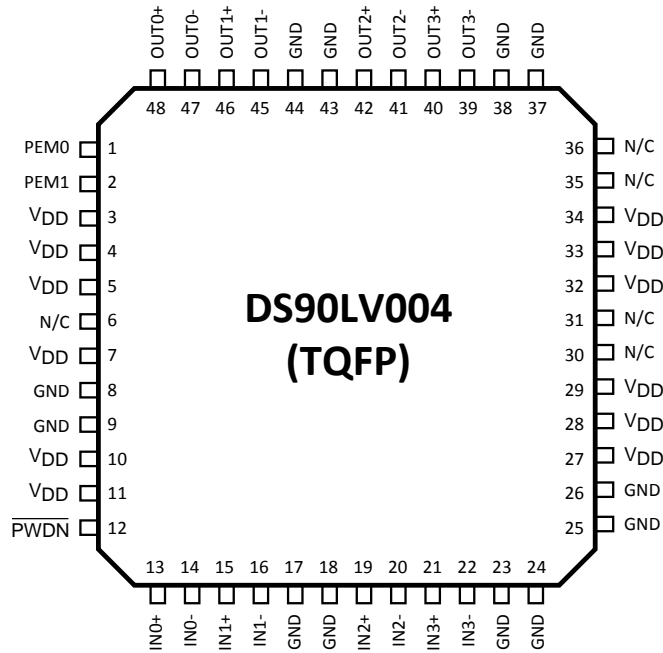

Figure 2. TQFP Pinout - Top View

Pin Descriptions

Pin Name	TQFP Pin Number	I/O, Type	Description
DIFFERENTIAL INPUTS			
IN0+ IN0–	13 14	I, LVDS	Channel 0 inverting and non-inverting differential inputs.
IN1+ IN1–	15 16	I, LVDS	Channel 1 inverting and non-inverting differential inputs.
IN2+ IN2–	19 20	I, LVDS	Channel 2 inverting and non-inverting differential inputs.
IN3+ IN3–	21 22	I, LVDS	Channel 3 inverting and non-inverting differential inputs.
DIFFERENTIAL OUTPUTS			
OUT0+ OUT0–	48 47	O, LVDS	Channel 0 inverting and non-inverting differential outputs. ⁽¹⁾
OUT1+ OUT1–	46 45	O, LVDS	Channel 1 inverting and non-inverting differential outputs. ⁽¹⁾
OUT2+ OUT2–	42 41	O, LVDS	Channel 2 inverting and non-inverting differential outputs. ⁽¹⁾
OUT3+ OUT3–	40 39	O, LVDS	Channel 3 inverting and non-inverting differential outputs. ⁽¹⁾
DIGITAL CONTROL INTERFACE			
$\overline{\text{PWDN}}$	12	I, LVTTTL	A logic low at $\overline{\text{PWDN}}$ activates the hardware power down mode.
PEM0 PEM1	1 2	I, LVTTTL	Pre-emphasis Control Inputs (affects all Channels)
POWER			
V _{DD}	3, 4, 5, 7, 10, 11, 27, 28, 29, 32, 33, 34	I, Power	V _{DD} = 3.3V, ±5%
GND	8, 9, 17, 18, 23, 24, 25, 26, 37, 38, 43, 44	I, Power	Ground reference for LVDS and CMOS circuitry.
N/C	6, 30, 31, 35, 36		No Connect

(1) The LVDS outputs do not support a multidrop (BLVDS) environment. The LVDS output characteristics of the DS90LV004 device have been optimized for point-to-point backplane and cable applications.



These devices have limited built-in ESD protection. The leads should be shorted together or the device placed in conductive foam during storage or handling to prevent electrostatic damage to the MOS gates.

Absolute Maximum Ratings ⁽¹⁾

Supply Voltage (V_{DD})	-0.3V to +4.0V
CMOS Input Voltage	-0.3V to ($V_{DD}+0.3V$)
LVDS Input Voltage ⁽²⁾	-0.3V to ($V_{DD}+0.3V$)
LVDS Output Voltage	-0.3V to ($V_{DD}+0.3V$)
LVDS Output Short Circuit Current	-90 mA
Junction Temperature	+150°C
Storage Temperature	-65°C to +150°C
Lead Temperature (Solder, 4sec)	260°C
Max Pkg Power Capacity @ 25°C	1.64W
Thermal Resistance (θ_{JA})	76°C/W
Package Derating above +25°C	13.2mW/°C
ESD Last Passing Voltage (LVDS Output pins)	
HBM, 1.5k Ω , 100pF	12 kV
EIAJ, 0 Ω , 200pF	250V
Charged Device Model	1000V
ESD Last Passing Voltage (All other pins)	
HBM, 1.5k Ω , 100pF	8 kV
EIAJ, 0 Ω , 200pF	250V
Charged Device Model	1000V

(1) Absolute maximum ratings are those values beyond which damage to the device may occur. The databook specifications should be met, without exception, to ensure that the system design is reliable over its power supply, temperature, and output/input loading variables. TI does not recommend operation of products outside of recommended operation conditions.

(2) V_{ID} max < 2.4V

Recommended Operating Conditions

Supply Voltage (V_{CC})	3.15V to 3.45V
Input Voltage (V_I) ⁽¹⁾	0V to V_{CC}
Output Voltage (V_O)	0V to V_{CC}
Operating Temperature (T_A)	
Industrial	-40°C to +85°C

(1) V_{ID} max < 2.4V

Electrical Characteristics

Over recommended operating supply and temperature ranges unless other specified.

Symbol	Parameter	Conditions	Min	Typ (1)	Max	Units
LVTTL DC SPECIFICATIONS (\overline{PWDN} , PEM0, PEM1)						
V_{IH}	High Level Input Voltage		2.0		V_{DD}	V
V_{IL}	Low Level Input Voltage		GND		0.8	V
I_{IH}	High Level Input Current	$V_{IN} = V_{DD} = V_{DDMAX}$	-10		+10	μ A
I_{IL}	Low Level Input Current	$V_{IN} = V_{SS}, V_{DD} = V_{DDMAX}$	-10		+10	μ A
C_{IN1}	Input Capacitance	Any Digital Input Pin to V_{SS}		3.5		pF
V_{CL}	Input Clamp Voltage	$I_{CL} = -18$ mA	-1.5	-0.8		V
LVDS INPUT DC SPECIFICATIONS ($IN_{n\pm}$)						
V_{TH}	Differential Input High Threshold ⁽²⁾	$V_{CM} = 0.8V$ to 3.4V, $V_{DD} = 3.45V$		0	100	mV
V_{TL}	Differential Input Low Threshold ⁽²⁾	$V_{CM} = 0.8V$ to 3.4V, $V_{DD} = 3.45V$	-100	0		mV
V_{ID}	Differential Input Voltage	$V_{CM} = 0.8V$ to 3.4V, $V_{DD} = 3.45V$	100		2400	mV

(1) Typical parameters are measured at $V_{DD} = 3.3V$, $T_A = 25^\circ C$. They are for reference purposes, and are not production-tested.

(2) Differential output voltage V_{OD} is defined as $ABS(OUT+ - OUT-)$. Differential input voltage V_{ID} is defined as $ABS(IN+ - IN-)$.

Electrical Characteristics (continued)

Over recommended operating supply and temperature ranges unless other specified.

Symbol	Parameter	Conditions	Min	Typ (1)	Max	Units
V_{CMR}	Common Mode Voltage Range	$V_{ID} = 150\text{ mV}$, $V_{DD} = 3.45\text{ V}$	0.05		3.40	V
C_{IN2}	Input Capacitance	IN+ or IN- to V_{SS}		3.5		pF
I_{IN}	Input Current	$V_{IN} = 3.45\text{ V}$, $V_{DD} = V_{DDMAX}$	-10		+10	μA
		$V_{IN} = 0\text{ V}$, $V_{DD} = V_{DDMAX}$	-10		+10	μA
LVDS OUTPUT DC SPECIFICATIONS (OUTn±)						
V_{OD}	Differential Output Voltage, 0% Pre-emphasis (2)	$R_L = 100\Omega$ external resistor between OUT+ and OUT-	250	500	600	mV
ΔV_{OD}	Change in V_{OD} between Complementary States		-35		35	mV
V_{OS}	Offset Voltage (3)		1.05	1.18	1.475	V
ΔV_{OS}	Change in V_{OS} between Complementary States		-35		35	mV
I_{OS}	Output Short Circuit Current	OUT+ or OUT- Short to GND		-60	-90	mA
C_{OUT2}	Output Capacitance	OUT+ or OUT- to GND when TRI-STATE®		5.5		pF
SUPPLY CURRENT (Static)						
I_{CC}	Supply Current	All inputs and outputs enabled and active, terminated with differential load of 100Ω between OUT+ and OUT-, 0% pre-emphasis		117	140	mA
I_{CCZ}	Supply Current - Power Down Mode	$\overline{\text{PWDN}} = \text{L}$, 0% pre-emphasis		2.7	6	mA
SWITCHING CHARACTERISTICS—LVDS OUTPUTS						
t_{LHT}	Differential Low to High Transition Time	Use an alternating 1 and 0 pattern at 200 Mbps, measure between 20% and 80% of V_{OD} . (4)		210	300	ps
t_{HLT}	Differential High to Low Transition Time				210	300
t_{PLHD}	Differential Low to High Propagation Delay	Use an alternating 1 and 0 pattern at 200 Mbps, measure at 50% V_{OD} between input to output.		2.0	3.2	ns
t_{PHLD}	Differential High to Low Propagation Delay				2.0	3.2
t_{SKD1}	Pulse Skew	$ t_{PLHD} - t_{PHLD} $ (4)		25	80	ps
t_{SKCC}	Output Channel to Channel Skew	Difference in propagation delay (t_{PLHD} or t_{PHLD}) among all output channels. (4)		50	125	ps
t_{SKP}	Part to Part Skew	Common Edge, parts at same temp and V_{CC} (4)			1.1	ns
t_{JIT}	Jitter (0% Pre-emphasis) (5)	RJ - Alternating 1 and 0 at 750 MHz (6)		1.1	1.5	psrms
		DJ - K28.5 Pattern, 1.5 Gbps (7)		43	62	psp-p
		TJ - PRBS 2 ²³ -1 Pattern, 1.5 Gbps (8)		35	85	psp-p
t_{ON}	LVDS Output Enable Time	Time from $\overline{\text{PWDN}}$ to OUT± change from TRI-STATE to active.			300	ns
t_{OFF}	LVDS Output Disable Time	Time from $\overline{\text{PWDN}}$ to OUT± change from active to TRI-STATE.			12	ns

(3) Output offset voltage V_{OS} is defined as the average of the LVDS single-ended output voltages at logic high and logic low states.

(4) Not production tested. Ensured by a statistical analysis on a sample basis at the time of characterization.

(5) Jitter is not production tested, but ensured through characterization on a sample basis.

(6) Random Jitter, or RJ, is measured RMS with a histogram including 1500 histogram window hits. The input voltage = $V_{ID} = 500\text{ mV}$, 50% duty cycle at 750MHz, $t_r = t_f = 50\text{ ps}$ (20% to 80%).

(7) Deterministic Jitter, or DJ, is measured to a histogram mean with a sample size of 350 hits. The input voltage = $V_{ID} = 500\text{ mV}$, K28.5 pattern at 1.5 Gbps, $t_r = t_f = 50\text{ ps}$ (20% to 80%). The K28.5 pattern is repeating bit streams of (0011111010 1100000101).

(8) Total Jitter, or TJ, is measured peak to peak with a histogram including 3500 window hits. Stimulus and fixture Jitter has been subtracted. The input voltage = $V_{ID} = 500\text{ mV}$, 2²³-1 PRBS pattern at 1.5 Gbps, $t_r = t_f = 50\text{ ps}$ (20% to 80%).

FEATURE DESCRIPTIONS

INTERNAL TERMINATIONS

The DS90LV004 has integrated termination resistors on both the input and outputs. The inputs have a 100 Ω resistor across the differential pair, placing the receiver termination as close as possible to the input stage of the device. The LVDS outputs also contain an integrated 100 Ω ohm termination resistor, this resistor is used to reduce the effects of Near End Crosstalk (NEXT) and does not take the place of the 100 ohm termination at the inputs to the receiving device. The integrated terminations improve signal integrity and decrease the external component count resulting in space savings.

OUTPUT CHARACTERISTICS

The output characteristics of the DS90LV004 have been optimized for point-to-point backplane and cable applications, and are not intended for multipoint or multidrop signaling.

POWERDOWN MODE

The $\overline{\text{PWDN}}$ input activates a hardware powerdown mode. When the powerdown mode is active ($\overline{\text{PWDN}}=\text{L}$), all input and output buffers and internal bias circuitry are powered off and disabled. Outputs are tri-stated in powerdown mode. When exiting powerdown mode, there is a delay associated with turning on bandgap references and input/output buffer circuits as indicated in the LVDS Output Switching Characteristics

PRE-EMPHASIS

Pre-emphasis dramatically reduces ISI jitter from long or lossy transmission media. Two pins are used to select the pre-emphasis level for all outputs: off, low, medium, or high.

Table 1. Pre-Emphasis Control Selection Table

PEM1	PEM0	Pre-Emphasis
0	0	Off
0	1	Low
1	0	Medium
1	1	High

INPUT FAILSAFE BIASING

External pull up and pull down resistors may be used to provide enough of an offset to enable an input failsafe under open-circuit conditions. This configuration ties the positive LVDS input pin to V_{DD} thru a pull up resistor and the negative LVDS input pin is tied to GND by a pull down resistor. The pull up and pull down resistors should be in the 5k Ω to 15k Ω range to minimize loading and waveform distortion to the driver. The common-mode bias point ideally should be set to approximately 1.2V (less than 1.75V) to be compatible with the internal circuitry. Please refer to application note AN-1194 "Failsafe Biasing of LVDS Interfaces" ([SNLA051](#)) for more information.

INPUT INTERFACING

The DS90LV004 accepts differential signals and allow simple AC or DC coupling. With a wide common mode range, the DS90LV004 can be DC-coupled with all common differential drivers (i.e. LVPECL, LVDS, CML). [Figure 3](#), [Figure 4](#), and [Figure 5](#) illustrate typical DC-coupled interface to common differential drivers. Note that the DS90LV004 inputs are internally terminated with a 100 Ω resistor.

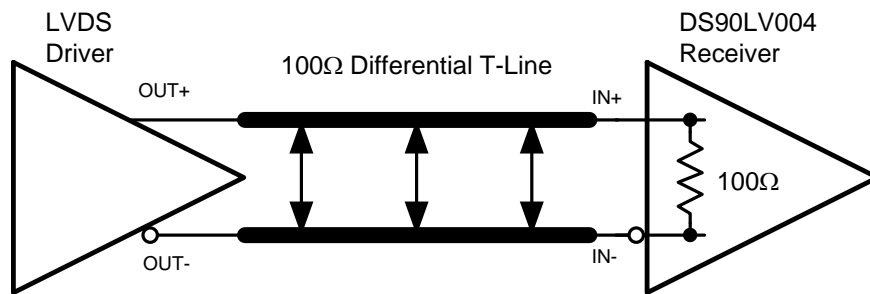

Figure 3. Typical LVDS Driver DC-Coupled Interface to DS90LV004 Input

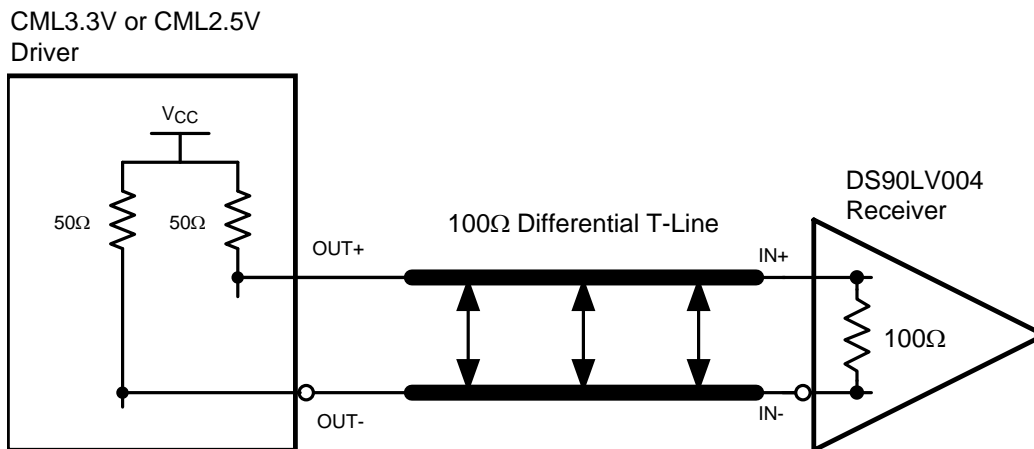

Figure 4. Typical CML Driver DC-Coupled Interface to DS90LV004 Input

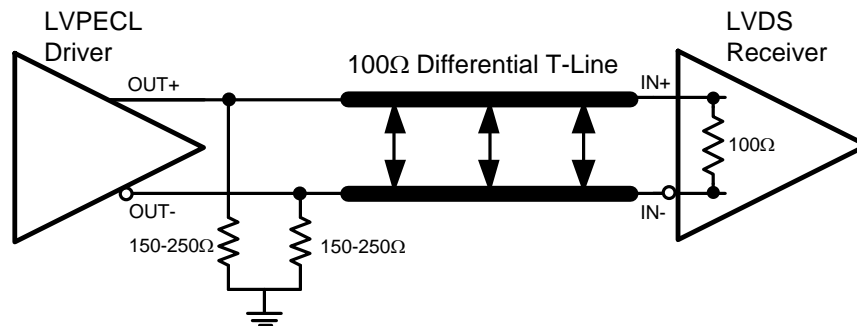

Figure 5. Typical LVPECL Driver DC-Coupled Interface to DS90LV004 Input

OUTPUT INTERFACING

The DS90LV004 outputs signals that are compliant to the LVDS standard. Their outputs can be DC-coupled to most common differential receivers. Figure 6 illustrates typical DC-coupled interface to common differential receivers and assumes that the receivers have high impedance inputs. While most differential receivers have a common mode input range that can accommodate LVDS compliant signals, it is recommended to check respective receiver's data sheet prior to implementing the suggested interface implementation.

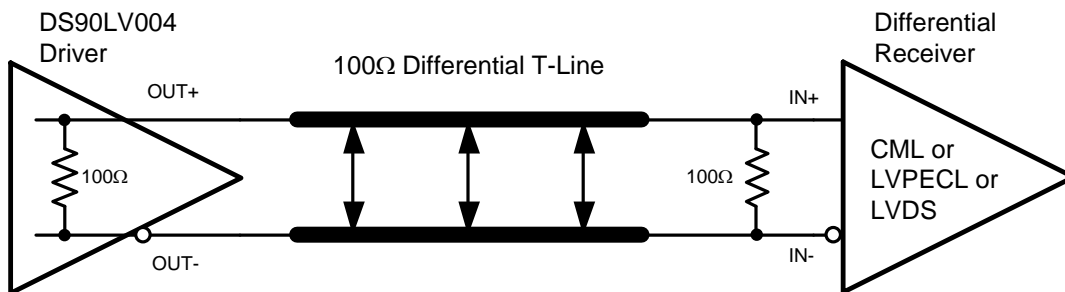

Figure 6. Typical DS90LV004 Output DC-Coupled Interface to an LVDS, CML or LVPECL Receiver

TYPICAL PERFORMANCE CHARACTERISTICS

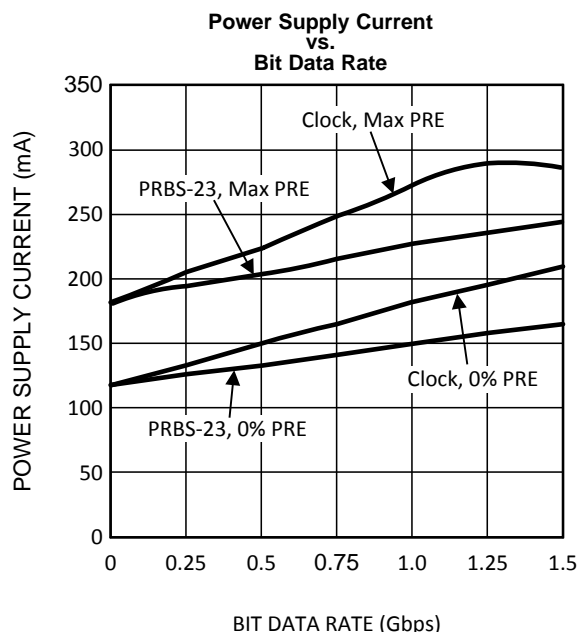

Figure 7.

Dynamic power supply current was measured while running a clock or PRBS $2^{23}-1$ pattern with all 4 channels active. $V_{CC} = 3.3V$, $T_A = +25^{\circ}C$, $V_{ID} = 0.5V$, $V_{CM} = 1.2V$

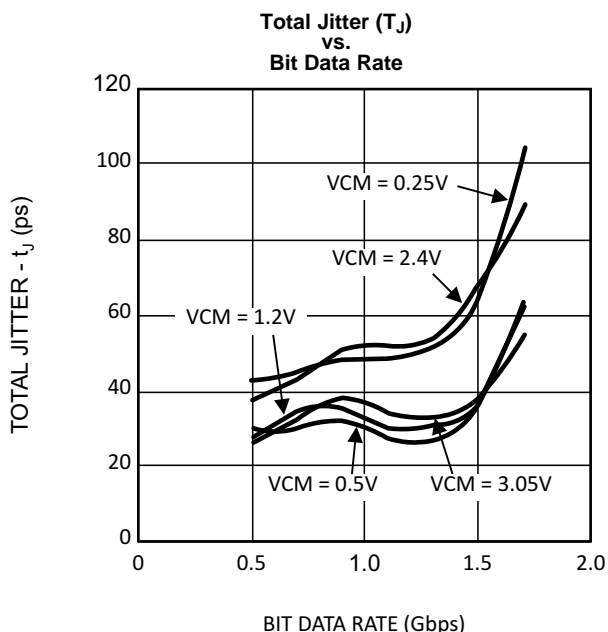

Figure 8.

Total Jitter measured at 0V differential while running a PRBS $2^{23}-1$ pattern with a single channel active. $V_{CC} = 3.3V$, $T_A = +25^{\circ}C$, $V_{ID} = 0.5V$, 0% Pre-emphasis

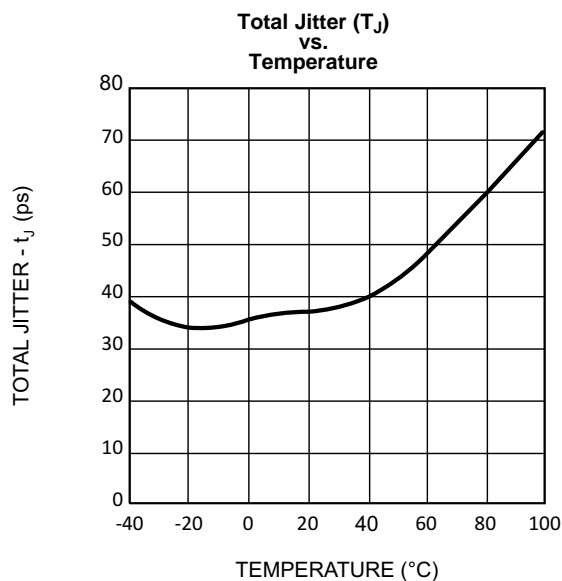

Figure 9.

Total Jitter measured at 0V differential while running a PRBS $2^{23}-1$ pattern with a single channel active. $V_{CC} = 3.3V$, $V_{ID} = 0.5V$, $V_{CM} = 1.2V$, 1.5 Gbps data rate, 0% Pre-emphasis

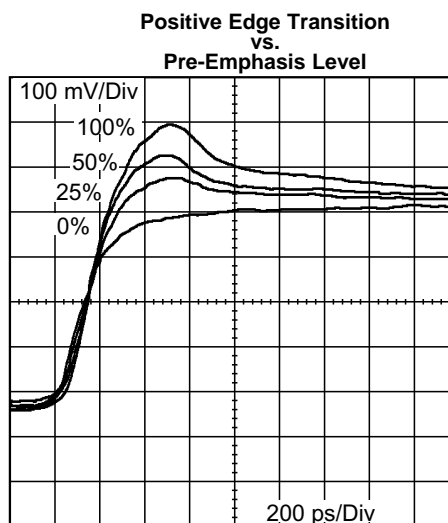

Figure 10.

REVISION HISTORY

Changes from Revision O (April 2013) to Revision P	Page
• Changed layout of National Data Sheet to TI format	9

PACKAGING INFORMATION

Orderable Device	Status (1)	Package Type	Package Drawing	Pins	Package Qty	Eco Plan (2)	Lead/Ball Finish (6)	MSL Peak Temp (3)	Op Temp (°C)	Device Marking (4/5)	Samples
DS90LV004TVS	NRND	TQFP	PFB	48	250	TBD	Call TI	Call TI	-40 to 85	DS90LV004TVS	
DS90LV004TVS/NOPB	ACTIVE	TQFP	PFB	48	250	Green (RoHS & no Sb/Br)	SN	Level-3-260C-168 HR	-40 to 85	DS90LV004TVS	Samples

(1) The marketing status values are defined as follows:

ACTIVE: Product device recommended for new designs.

LIFEBUY: TI has announced that the device will be discontinued, and a lifetime-buy period is in effect.

NRND: Not recommended for new designs. Device is in production to support existing customers, but TI does not recommend using this part in a new design.

PREVIEW: Device has been announced but is not in production. Samples may or may not be available.

OBSOLETE: TI has discontinued the production of the device.

(2) **RoHS:** TI defines "RoHS" to mean semiconductor products that are compliant with the current EU RoHS requirements for all 10 RoHS substances, including the requirement that RoHS substance do not exceed 0.1% by weight in homogeneous materials. Where designed to be soldered at high temperatures, "RoHS" products are suitable for use in specified lead-free processes. TI may reference these types of products as "Pb-Free".

RoHS Exempt: TI defines "RoHS Exempt" to mean products that contain lead but are compliant with EU RoHS pursuant to a specific EU RoHS exemption.

Green: TI defines "Green" to mean the content of Chlorine (Cl) and Bromine (Br) based flame retardants meet JS709B low halogen requirements of <=1000ppm threshold. Antimony trioxide based flame retardants must also meet the <=1000ppm threshold requirement.

(3) MSL, Peak Temp. - The Moisture Sensitivity Level rating according to the JEDEC industry standard classifications, and peak solder temperature.

(4) There may be additional marking, which relates to the logo, the lot trace code information, or the environmental category on the device.

(5) Multiple Device Markings will be inside parentheses. Only one Device Marking contained in parentheses and separated by a "~" will appear on a device. If a line is indented then it is a continuation of the previous line and the two combined represent the entire Device Marking for that device.

(6) Lead/Ball Finish - Orderable Devices may have multiple material finish options. Finish options are separated by a vertical ruled line. Lead/Ball Finish values may wrap to two lines if the finish value exceeds the maximum column width.

Important Information and Disclaimer:The information provided on this page represents TI's knowledge and belief as of the date that it is provided. TI bases its knowledge and belief on information provided by third parties, and makes no representation or warranty as to the accuracy of such information. Efforts are underway to better integrate information from third parties. TI has taken and continues to take reasonable steps to provide representative and accurate information but may not have conducted destructive testing or chemical analysis on incoming materials and chemicals. TI and TI suppliers consider certain information to be proprietary, and thus CAS numbers and other limited information may not be available for release.

In no event shall TI's liability arising out of such information exceed the total purchase price of the TI part(s) at issue in this document sold by TI to Customer on an annual basis.

PFB (S-PQFP-G48)

PLASTIC QUAD FLATPACK

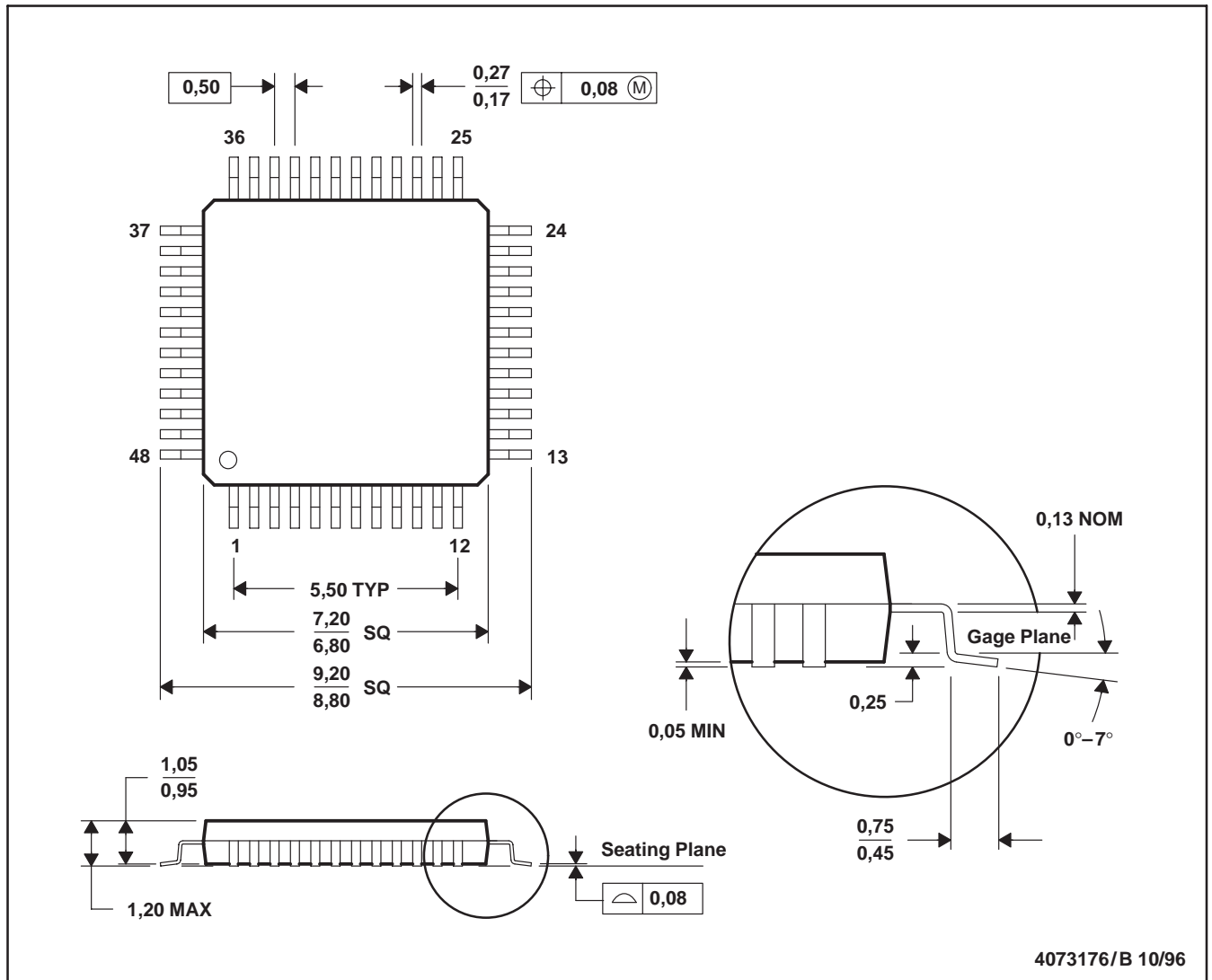

- NOTES: A. All linear dimensions are in millimeters.
 B. This drawing is subject to change without notice.
 C. Falls within JEDEC MS-026

PFB (S-PQFP-G48)

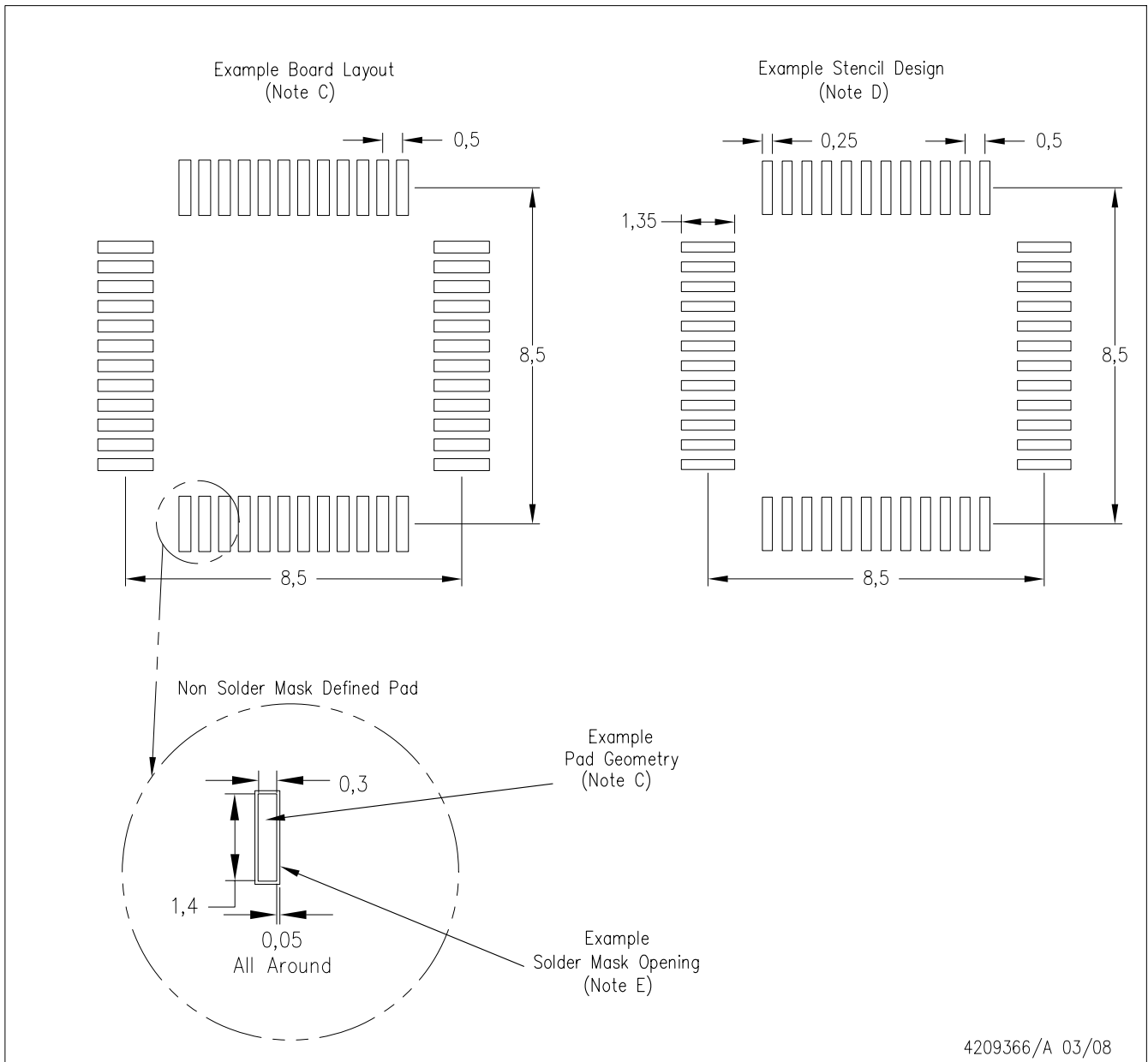

- NOTES:
- A. All linear dimensions are in millimeters.
 - B. This drawing is subject to change without notice.
 - C. Publication IPC-7351 is recommended for alternate designs.
 - D. Laser cutting apertures with trapezoidal walls and also rounding corners will offer better paste release. Customers should contact their board assembly site for stencil design recommendations. Refer to IPC-7525.
 - E. Customers should contact their board fabrication site for solder mask tolerances between and around signal pads.

IMPORTANT NOTICE AND DISCLAIMER

TI PROVIDES TECHNICAL AND RELIABILITY DATA (INCLUDING DATASHEETS), DESIGN RESOURCES (INCLUDING REFERENCE DESIGNS), APPLICATION OR OTHER DESIGN ADVICE, WEB TOOLS, SAFETY INFORMATION, AND OTHER RESOURCES "AS IS" AND WITH ALL FAULTS, AND DISCLAIMS ALL WARRANTIES, EXPRESS AND IMPLIED, INCLUDING WITHOUT LIMITATION ANY IMPLIED WARRANTIES OF MERCHANTABILITY, FITNESS FOR A PARTICULAR PURPOSE OR NON-INFRINGEMENT OF THIRD PARTY INTELLECTUAL PROPERTY RIGHTS.

These resources are intended for skilled developers designing with TI products. You are solely responsible for (1) selecting the appropriate TI products for your application, (2) designing, validating and testing your application, and (3) ensuring your application meets applicable standards, and any other safety, security, or other requirements. These resources are subject to change without notice. TI grants you permission to use these resources only for development of an application that uses the TI products described in the resource. Other reproduction and display of these resources is prohibited. No license is granted to any other TI intellectual property right or to any third party intellectual property right. TI disclaims responsibility for, and you will fully indemnify TI and its representatives against, any claims, damages, costs, losses, and liabilities arising out of your use of these resources.

TI's products are provided subject to TI's Terms of Sale (www.ti.com/legal/termsofsale.html) or other applicable terms available either on ti.com or provided in conjunction with such TI products. TI's provision of these resources does not expand or otherwise alter TI's applicable warranties or warranty disclaimers for TI products.

Mailing Address: Texas Instruments, Post Office Box 655303, Dallas, Texas 75265
Copyright © 2020, Texas Instruments Incorporated