

FEATURES

Initial Accuracy: ± 4 mV Max
Initial Accuracy Error: $\pm 0.2\%$
Low TCVO: ± 50 ppm/ $^{\circ}$ C Max from -40° C to $+125^{\circ}$ C,
30 ppm/ $^{\circ}$ C Max from $+25^{\circ}$ C to $+70^{\circ}$ C
Load Regulation: 200 μ V/mA, 100 ppm/mA
Line Regulation: 25 μ V/V, 20 ppm/V
Wide Operating Range: $V_{IN} = 2.3$ V to 15 V
Low Power: 72 μ A Max
High Output Sink/Source Current: ± 5 mA Min
Wide Temperature Range: -40° C to $+125^{\circ}$ C
Tiny 3-Lead SOT-23 Package with Standard Pinout

APPLICATIONS

Battery-Powered Instrumentation
Portable Medical Instruments
Data Acquisition Systems
Industrial Process Control Systems
Automotive

GENERAL DESCRIPTION

The ADR370 is a low cost, 3-terminal (series) band-gap voltage reference featuring high accuracy, high stability, and low power consumption packaged in a tiny 3-lead SOT-23 package. Precise matching and thermal tracking of on-chip components, as well as patented temperature drift curvature correction design techniques, have been employed to ensure that the ADR370 provides an accurate 2.048 V output.

This micropowered, low dropout voltage device will source or sink up to 5 mA of load current while providing a stable 2.048 V output. The compact footprint, high accuracy, and an operating range of 2.3 V to 12 V make the ADR370 ideal for use in 3 V and 5 V systems where there may be wide variations in supply voltage and a need to minimize power dissipation.

The ADR370 is offered in A and B grades; all devices are specified over the extended industrial range of -40° C to $+125^{\circ}$ C.

PIN CONFIGURATION

3-Lead SOT-23

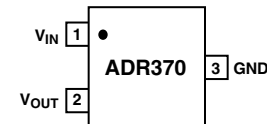

Table I. ADR370 Products

Products	Output Voltage (V_O)	Initial Accuracy		Temperature Coefficient ($\text{ppm}/^{\circ}\text{C}$)
		(mV)	(%)	
ADR370BRT-REEL7	2.048	4	0.2	50
ADR370ART-REEL7	2.048	10	0.5	100

*Protected by U.S. Patent No. 5,969,657; other patents pending.

REV. A

Information furnished by Analog Devices is believed to be accurate and reliable. However, no responsibility is assumed by Analog Devices for its use, nor for any infringements of patents or other rights of third parties that may result from its use. No license is granted by implication or otherwise under any patent or patent rights of Analog Devices. Trademarks and registered trademarks are the property of their respective companies.

ADR370—SPECIFICATIONS

ELECTRICAL CHARACTERISTICS (T_A = T_{MIN} to T_{MAX}, V_{IN} = 5 V, unless otherwise noted.)

Parameter	Symbol	Conditions	Min	Typ	Max	Unit
Output Voltage (@ 25°C)	V _O		2.044	2.048	2.052	V
Initial Accuracy Error						
A Grade	V _{OEERR}		-10		+10	mV
B Grade	V _{OEERR}		-0.5		+0.5	%
	V _{OEERR}		-4		+4	mV
	V _{OEERR}		-0.2		+0.2	%
Output Voltage Temperature Drift						
A Grade	TCV _O	-40°C to +125°C			100	ppm/°C
B Grade	TCV _O	-40°C to +125°C			50	ppm/°C
	TCV _O	25°C to 70°C			30	ppm/°C
Supply Headroom	V _{IN} - V _{OUT}		200			mV
Load Regulation						
		0 mA < I _{OUT} < 5 mA @ 25°C	-0.200		+0.200	mV/mA
		-3 mA < I _{OUT} < 0 mA @ 25°C	-0.480		+0.480	mV/mA
		-0.1 mA < I _{OUT} < +0.1 mA	-0.425		+0.425	mV/mA
Line Regulation		V _{OUT} 200 mV < V _{IN} < 15 V			20	ppm/V
		I _{OUT} = 0 mA				
Ripple Rejection	ΔV _{OUT} /ΔV _{IN}	V _{IN} = 5 V ± 100 mV (f = 120 Hz)	80			dB
Quiescent Current					72	μA
Short-Circuit Current to Ground					15	μA
Noise Voltage (@ 25°C)		0.1 Hz to 10 Hz		70		μV p-p
		10 Hz to 10 kHz		50		μV rms
Turn-On Settling Time	C _L = 0.2 μF			100		μs
Long Term Stability		1,000 Hours @ 25°C			100	ppm/1,000 hrs
Output Voltage Hysteresis				115		ppm
Temperature Range			-40		+125	°C

*Guaranteed by characterization.

Specifications subject to change without notice.

ABSOLUTE MAXIMUM RATINGS*

Supply Voltage	18 V
Storage Temperature Range	
RT Package	-65°C to +125°C
Operating Temperature Range	-40°C to +125°C
Lead Temperature Range	
Soldering, 60 sec	215°C
Infrared, 15 sec	220°C

*Absolute maximum ratings apply at 25°C, unless otherwise noted.

Package Type	θ_{JA}	θ_{JC}	Unit
3-SOT-23 (RT)	220	102	°C/W

ORDERING GUIDE

Model	Output Voltage (V _O)	Initial Accuracy		Temperature Coefficient (ppm/°C)	Package Description	Package Option	Branding	Number of Parts per Reel	Temperature Range
		(mV)	(%)						
ADR370BRT-R2	2.048	±4	0.5	50	SOT-23	3-Lead	RPB	250	-40°C to +125°C
ADR370BRT-REEL7	2.048	±4	0.2	50	SOT-23	3-Lead	RPB	3,000	-40°C to +125°C
ADR370ART-R2	2.048	±10	0.5	100	SOT-23	3-Lead	RPA	250	-40°C to +125°C
ADR370ART-REEL7	2.048	±10	0.5	100	SOT-23	3-Lead	RPA	3,000	-40°C to +125°C

CAUTION

ESD (electrostatic discharge) sensitive device. Electrostatic charges as high as 4000 V readily accumulate on the human body and test equipment and can discharge without detection. Although the ADR370 features proprietary ESD protection circuitry, permanent damage may occur on devices subjected to high energy electrostatic discharges. Therefore, proper ESD precautions are recommended to avoid performance degradation or loss of functionality.



ADR370—Typical Performance Characteristics

www.dataSheet4U.com

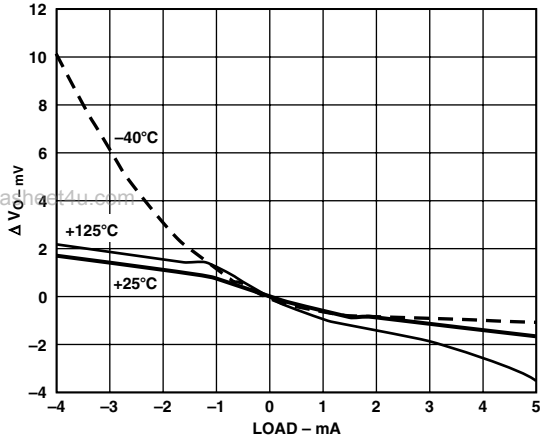

TPC 1. Load Regulation vs. Load Current

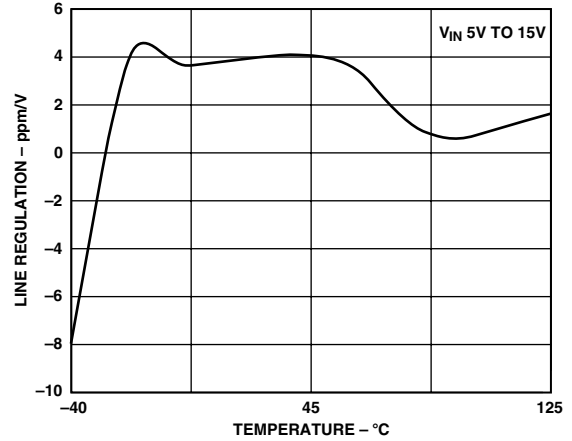

TPC 4. Line Regulation vs. Temperature

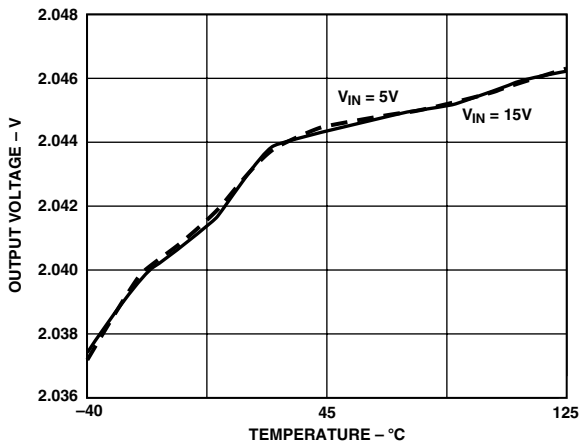

TPC 2. Output Voltage vs. Temperature

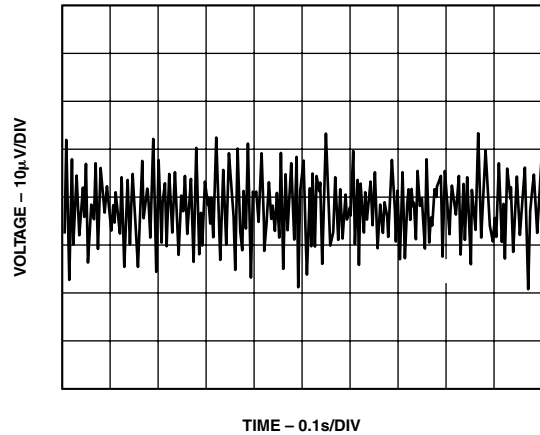

TPC 5. Voltage Noise 0.1 Hz to 10 Hz

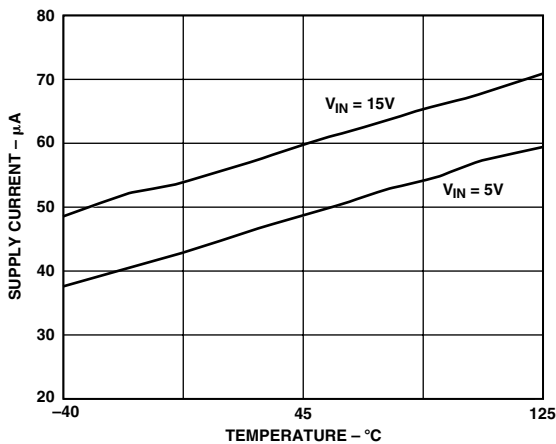

TPC 3. Supply Current vs. Temperature

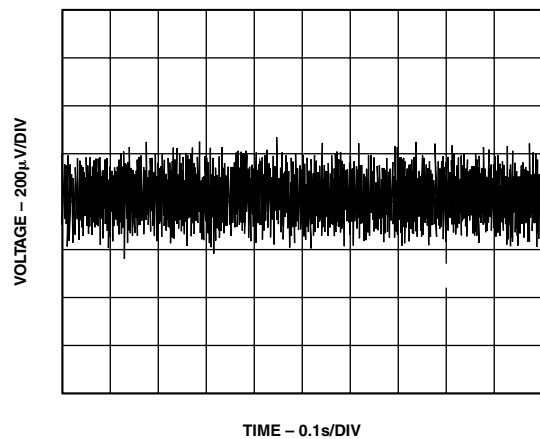

TPC 6. Voltage Noise 10 Hz to 100 kHz

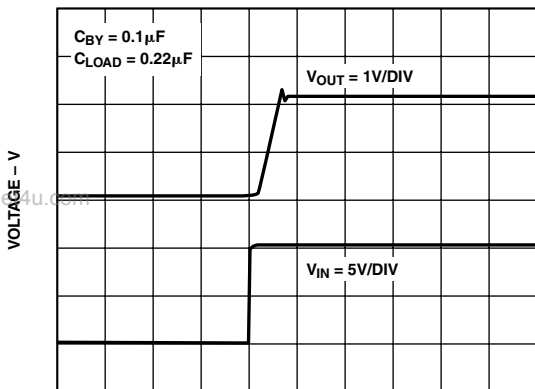

TIME – 100µs/DIV

TPC 7. Turn-On Response

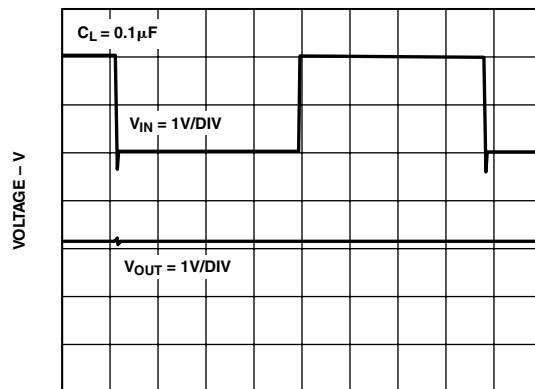

TIME – 100µs/DIV

TPC 9. Line Transient Response

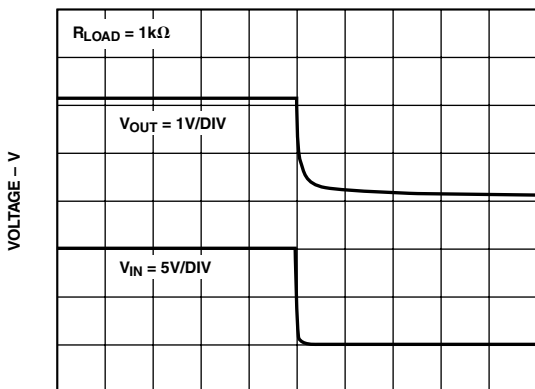

TIME – 100µs/DIV

TPC 8. Turn-Off Response

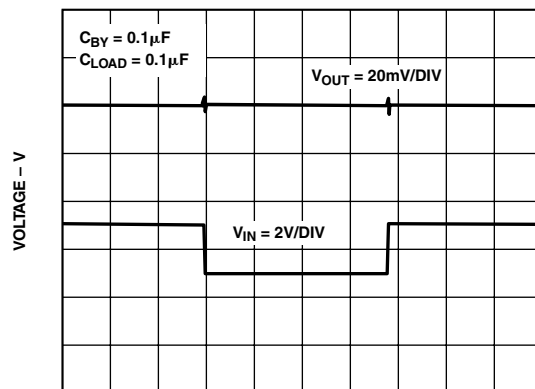

TIME – 100ms/DIV

TPC 10. Load Transient Response

ADR370

PARAMETER DEFINITIONS

Temperature Coefficient

Temperature coefficient is the change of output voltage with respect to operating temperature changes, normalized by the output voltage at 25°C. This parameter is expressed in ppm/°C and can be determined with the following equation

$$TCV_o \left[\frac{ppm}{^\circ C} \right] = \frac{V_o(T_2) - V_o(T_1)}{V_o(25^\circ C) \times (T_2 - T_1)} \times 10^6 \quad (1)$$

where:

$$V_o(25^\circ C) = V_o \text{ at } 25^\circ C.$$

$$V_o(T_1) = V_o \text{ at Temperature 1.}$$

$$V_o(T_2) = V_o \text{ at Temperature 2.}$$

Line Regulation

Line regulation is the change in output voltage due to a specified change in input voltage. This parameter accounts for the effects of self-heating. Line regulation is expressed in either percent per volt, parts-per-million per volt, or microvolts per volt change in input voltage.

Load Regulation

Load regulation is the change in output voltage due to a specified change in load current. This parameter accounts for the effects of self-heating. Load regulation is expressed in either microvolts per milliampere, parts-per-million per milliampere, or ohms of dc output resistance.

Long Term Stability

Long term stability is the typical shift of output voltage at 25°C on a sample of parts subjected to a test of 1,000 hours at 25°C.

$$\Delta V_o = V_o(t_0) - V_o(t_1)$$

$$\Delta V_o [ppm] = \frac{V_o(t_0) - V_o(t_1)}{V_o(t_0)} \times 10^6 \quad (2)$$

where:

$$V_o(T_1) = V_o \text{ at } 25^\circ C \text{ at time 0.}$$

$$V_o(T_2) = V_o \text{ at } 25^\circ C \text{ after 1,000 hours operation at } 25^\circ C.$$

Thermal Hysteresis

Thermal hysteresis is defined as the change of output voltage after the device is cycled through temperature from +25°C to -40°C to +125°C and back to +25°C. This is a typical value from a sample of parts put through such a cycle.

$$V_{o_HYS} = V_o(25^\circ C) - V_{o_TC}$$

$$V_{o_HYS} [ppm] = \frac{V_o(25^\circ C) - V_{o_TC}}{V_o(25^\circ C)} \times 10^6 \quad (3)$$

where:

$$V_o(25^\circ C) = V_o \text{ at } 25^\circ C.$$

$$V_{o_TC} = V_o \text{ at } 25^\circ C \text{ after temperature cycle at } +25^\circ C \text{ to } -40^\circ C \text{ to } +125^\circ C \text{ and back to } +25^\circ C.$$

THEORY OF OPERATION

The ADR370 uses the band-gap concept to produce a stable, low temperature coefficient voltage reference suitable for high accuracy data acquisition components and systems. This device makes use of underlying temperature characteristics of a silicon transistor's base-emitter voltage (V_{BE}) in the forward biased operating region. Under this condition, all such transistors have a $-2 \text{ mV}/^\circ C$ temperature coefficient (TC) and a V_{BE} that, when extrapolated to absolute zero, 0 K, (with collector current proportional to absolute temperature) approximates the silicon band-gap voltage. By summing a voltage that has an equal and opposite temperature coefficient of $2 \text{ mV}/^\circ C$ with a V_{BE} of a forward biased transistor, an almost zero TC reference can be developed. The simplified circuit diagram in Figure 1 shows how a compensating voltage, V_1 , is achieved by driving two transistors at different current densities and amplifying the resultant V_{BE} difference (ΔV_{BE} , which has a positive TC). The sum (V_{BG}) of V_{BE} and V_1 is then buffered and amplified to produce a stable reference voltage of 2.048 V at the output.

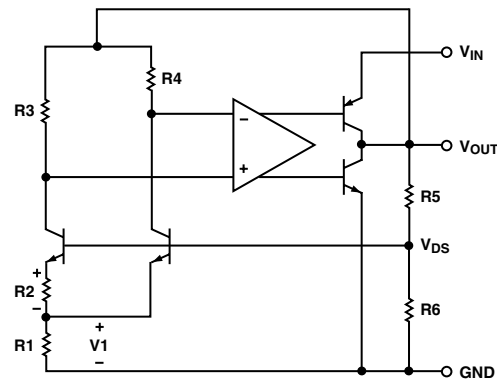

Figure 1. Simplified Schematic

Applying the ADR370

In order to achieve the specified performance, two external components should be used in conjunction with the ADR370, a $4.7 \mu F$ capacitor and a $1 \mu F$ capacitor should be applied to the input and output, respectively. Figure 2 shows the ADR370 with both the input and output capacitors attached.

For further transient response optimization, an additional $0.1 \mu F$ capacitor in parallel with the $4.7 \mu F$ input capacitor can be used.

A $1 \mu F$ output capacitor will provide stable performance for all loading conditions. The ADR370 can, however, operate under low ($-100 \mu A < I_{OUT} < +100 \mu A$) current conditions with just a $0.2 \mu F$ output capacitor and a $1 \mu F$ input capacitor.

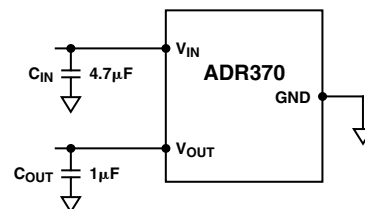

Figure 2. Typical Connection Diagram

APPLICATIONS

Low Cost Negative Reference

A low cost negative reference can be obtained by leveraging the current sinking capability of the ADR370. Simply tying the V_{OUT} terminal to ground and adding a bias resistor, R_{SET} , to the GND pin of the device, a negative voltage reference can be obtained as shown in Figure 3. R_{SET} should be chosen such that I_{SET} remains between 1 mA to 5 mA.

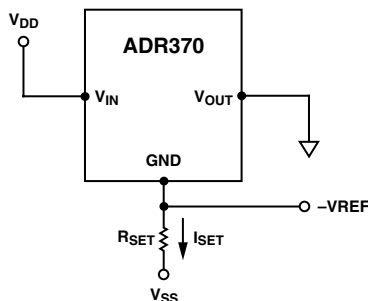

Figure 3. Low Cost Negative Reference

Precision Negative Reference

Without using any matching resistors, a precision negative reference can be obtained using the configuration shown in Figure 4. The voltage difference between V_{OUT} and GND of the ADR370 is 2.048 V. Since V_{OUT} is at virtual ground, U2 will close the loop by forcing the GND pin to be the negative reference node. U2 should be a low offset voltage precision op amp, such as the OP1177.

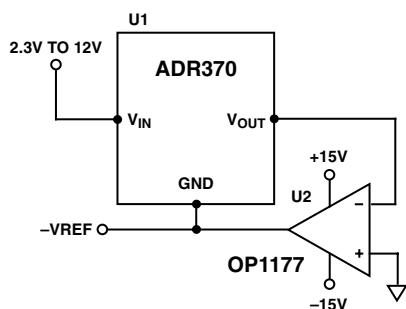

Figure 4. Precision Negative Reference

Low Cost Current Source

Figure 5 illustrates how a simple, low cost current source can be configured using the ADR370. The load current, I_L , is simply the sum of I_{SET} and the quiescent current, I_q . I_{SET} is simply the reference voltage generated by the ADR370 divided by R_{SET} .

$$I_{SET} = \frac{2.048V}{R_{SET}} \quad (4)$$

The quiescent current, I_q , varies slightly with load. The variation in I_q limits the use of this circuit to general-purpose applications.

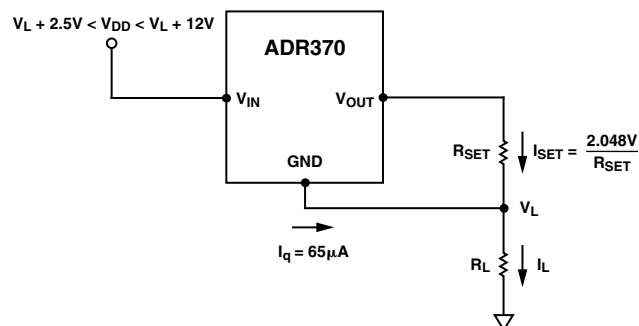

Figure 5. Low Cost Current Source

Precision Current Source with Adjustable Output

A precision current source can be implemented with the circuit shown in Figure 6. By adding a mechanical or digital potentiometer, this circuit becomes an adjustable current source. If a digital potentiometer like the AD5201 is used, the load current is simply the voltage across terminals B-to-W of the digital potentiometer divided by R_{SET} .

$$I_L = \frac{V_{REF} \times D}{R_{SET} \times 256} \quad (5)$$

where D is the decimal equivalent of the digital potentiometer input code.

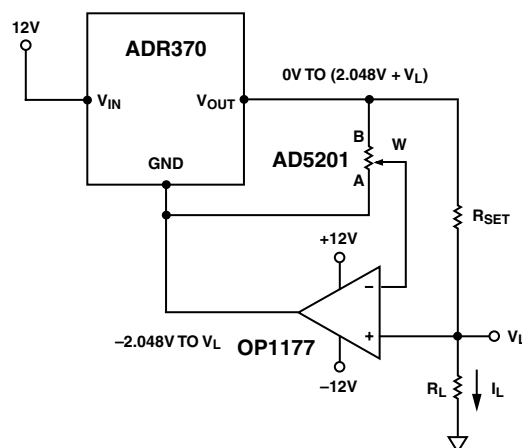

Figure 6. Programmable 0 mA to 5 mA Current Source

To optimize the resolution of this circuit, dual supply op amps should be used because the ground potential of ADR370 can swing from -2.048 V at zero scale to V_L at full scale of the potentiometer setting.

ADR370

12-Bit Precision Programmable Current Source

By replacing the potentiometer in Figure 6 with a 12-bit precision DAC like the AD5322, a higher precision programmable current source can be achieved. Figure 7 illustrates the implementation of this circuit. The load current can be determined with the following equation.

$$I_L = \frac{V_{REF}(1-D)}{R_{SET} \times 4096} \quad (6)$$

The compliance voltage should be kept low so that the supply voltage to U2, between V_{DD} and GND, does not fall below 2.5 V.

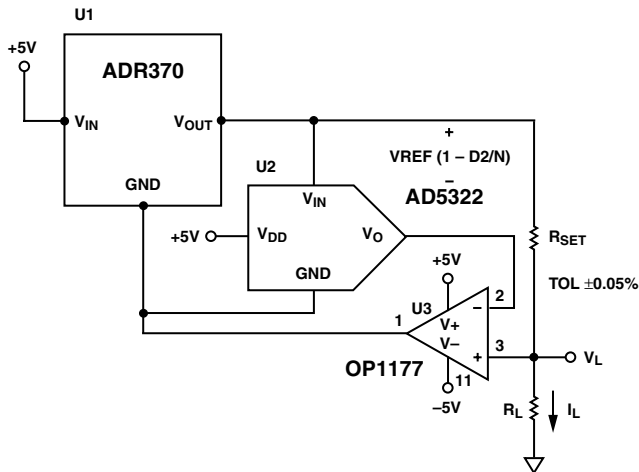

Figure 7. 12-Bit Programmable Current Source

Precision Boosted Output Regulator

A precision voltage output with boosted current can be realized with the circuit shown in Figure 8. In this circuit, V_O is maintained by the ADR370 at 2.048 V.

The ADR370 sources a maximum of 5 mA if the load current, I_L , is more than 5 mA, current is furnished by the transistor, Q1, and the input voltage supply V_{DD} .

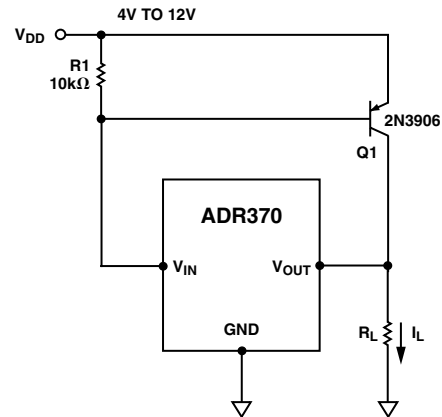

Figure 8. Precision Boosted Output Regulator

Q1 will be turned on to regulate current as needed. R1 is required to bias the base of Q1 and must be large enough to comply with the supply current requirements of the ADR370. The supply voltage can be as low as 4 V.

The maximum current output of this circuit is limited by the power dissipation of the bipolar transistor, Q1.

$$P_{DISS} = (V_{DD} - 2.048) \times I_L \quad (7)$$

Using the 2N3906 PNP transistor shown in Figure 8 and a 4 V power supply, R_L should be chosen so that a maximum of 100 mA is drawn from the circuit, which limits the power dissipation of Q1 to ~200 mW.

TAPE AND REEL DIMENSIONS

Dimensions shown in millimeters.

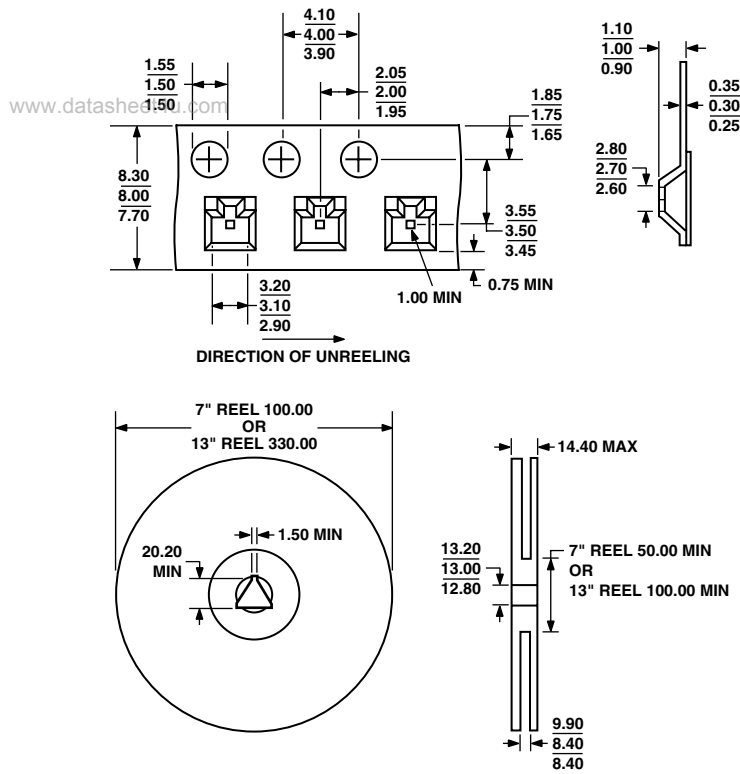

OUTLINE DIMENSIONS

3-Lead Small Outline Transistor Package [SOT-23-3] (RT-3)

Dimensions shown in millimeters.

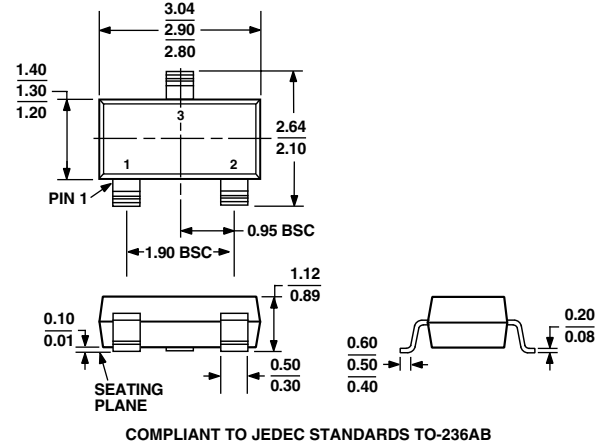

ADR370

Revision History

Location	Page
7/03—Data Sheet changed from REV. 0 to REV. A.	
Updated FEATURES	1
Updated Table I	1
Updated ELECTRICAL CHARACTERISTICS	2
Updated ABSOLUTE MAXIMUM RATINGS	3
Updated ORDERING GUIDE	3
Updated PARAMETER DEFINITIONS	6
Updated OUTLINE DIMENSIONS	9

