

bq501210 WPC v1.2 Wireless Power Transmitter Manager with 15-W Power Delivery

1 Features

- Qi-Certified Wireless Power Consortium (WPC) v1.2 Solution for 15-W Operation
 - Faster Charging Time
 - Backward Compatible With Existing 5-W WPC Receivers
- 12-V to 19-V Input, Fixed Frequency, Rail Voltage Control Architecture
 - 15 V to 19 V can achieve 15 W
 - 9 V and 12 V capable for HVDCP
 - Dynamic Power Limiting (DPL) Allows Operation From Weak Supplies
- Conforms to WPC MP-A5 Transmitter Type Specification
- Enhanced Foreign Object Detection (FOD) Implementation With FOD Ping that Detects Metal Objects Prior to Power Transfer
- Low Standby Power During Idle and 'Charge Complete'
- Bi-directional Communication
- Digital Demodulation Reduces Components and Simplifies Circuitry
- Support Fast Charge Operation with Compatible Receivers
- 10 Configurable LED Modes Indicate Charging State and Fault Status

2 Applications

- WPC v1.2 Wireless Chargers:
 - Smart Phones, Tablets, and Other Handhelds
 - Point-of-Sale Devices
 - Custom Wireless Power Applications

3 Description

The bq501210 is a Wireless Power Consortium (WPC) v1.2 compliant wireless power digital controller that integrates the logic functions required to wirelessly transfer power to a WPC-compliant receiver with the capability of delivering up to 15 W. The bq501210 is an intelligent device that periodically pings the surrounding environment for available devices to be powered, detects if a foreign metal object is present on the charging pad, monitors all communication from the device being wirelessly powered, and adjusts power applied to the transmitter coil per feedback received from the powered device. The bq501210 also manages the fault conditions associated with the power transfer and controls the operating mode status indicator. The bq501210 uses a rail voltage control scheme instead of the traditional frequency control to adjust the amount of power delivered to the receiver.

Through negotiation with a High Voltage Dedicated Charging Port (HVDCP) adapter, the bq501210 provides power between the WPC low power capability of 5 W, and the medium power specifications of 15 W.

Fast Charge support provides more power for compatible receiver devices.

See www.ti.com/wirelesspower for more information on TI's Wireless Charging Solutions

Device Information⁽¹⁾

PART NUMBER	PACKAGE	BODY SIZE (NOM)
bq501210	VQFN (64)	9.00 mm x 9.00 mm

(1) For all available packages, see the orderable addendum at the end of the data sheet.

Transmitter Solution Simplified Diagram

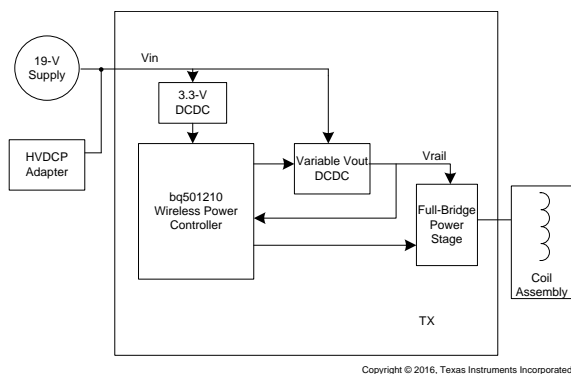

System Efficiency With Typical WPC 15-W Receiver

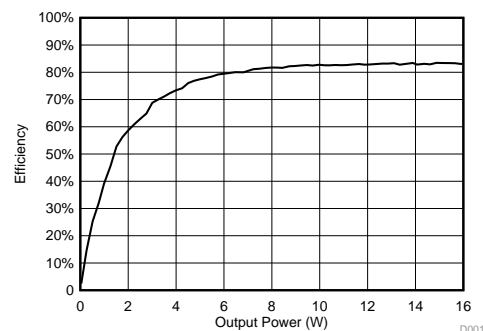

Table of Contents

1 Features	1	8.4 Device Functional Modes.....	16
2 Applications	1	9 Application and Implementation	19
3 Description	1	9.1 Application Information.....	19
4 Revision History	2	9.2 Typical Application	19
5 Device Comparison	3	10 Power Supply Recommendations	22
6 Pin Configuration and Functions	4	11 Layout	22
7 Specifications	7	11.1 Layout Guidelines	22
7.1 Absolute Maximum Ratings	7	11.2 Layout Example	22
7.2 ESD Ratings.....	7	12 Device and Documentation Support	28
7.3 Recommended Operating Conditions.....	7	12.1 Device Support.....	28
7.4 Thermal Information	7	12.2 Receiving Notification of Documentation Updates	28
7.5 Electrical Characteristics.....	8	12.3 Community Resources.....	28
7.6 Typical Characteristics.....	9	12.4 Trademarks	28
8 Detailed Description	10	12.5 Electrostatic Discharge Caution.....	28
8.1 Overview	10	12.6 Glossary	28
8.2 Functional Block Diagram	10	13 Mechanical, Packaging, and Orderable	
8.3 Feature Description.....	11	Information	28

4 Revision History

Changes from Revision B (July 2016) to Revision C

Page

- Changed [Features](#) From: Qi-Compatible Wireless Power Consortium To: Qi-Certified Wireless Power Consortium **1**
- Changed "WPC-compatible" To: "WPC-compliant" in the [Description](#)..... **1**
- Changed "WPC compatible" To: "WPC compliant" in the [Overview](#)..... **10**
- Changed "WPC compatible" To: "WPC compliant" in the [Application Information](#) **19**

Changes from Revision A (June 2016) to Revision B

Page

- Changed [Features](#) From: Qi-Certified Wireless Power Consortium To: Qi-Compatible Wireless Power Consortium..... **1**
- Deleted "Qi-Certified" in the [Applications](#) list..... **1**
- Changed "WPC-compliant" To: "WPC-compatible" in the [Description](#)..... **1**
- Changed "WPC compliant" To: "WPC compatible" in the [Overview](#)..... **10**
- Changed "WPC compliant" To: "WPC compatible" in the [Application Information](#) **19**

Changes from Original (April 2016) to Revision A

Page

- Changed from Product Preview To Production **1**

5 Device Comparison

DEVICE	FUNCTION	SYSTEM VIN	PROTOCOL	MAXIMUM DELIVERED POWER	NOTE
bq500212A	Wireless Power Transmitter Manager	5 V	WPC v1.1	5 W	1 Coil
bq500215	Wireless Power Transmitter Manager	12 V	WPC v1.1	10 W	1 Coil, 5 W or 10 W operation
bq500412	Wireless Power Transmitter Manager	5 V, 12 V	WPC v1.1	5 W	1, 2 or 3 Coils
bq500414Q	Wireless Power Transmitter Manager	12 V	WPC v1.1	5 W	1, 2 or 3 Coils, Automotive
bq500511 bq50002	Wireless Power Transmitter Controller Wireless Power Transmitter Analog Front End	5 V	WPC v1.1	5 W	1 Coil
bq501210	Wireless Power Transmitter Manager	12 V – 19 V	WPC v1.2	15 W	1 Coil

6 Pin Configuration and Functions

**RGC Package
64-Pin VQFN
Top View**

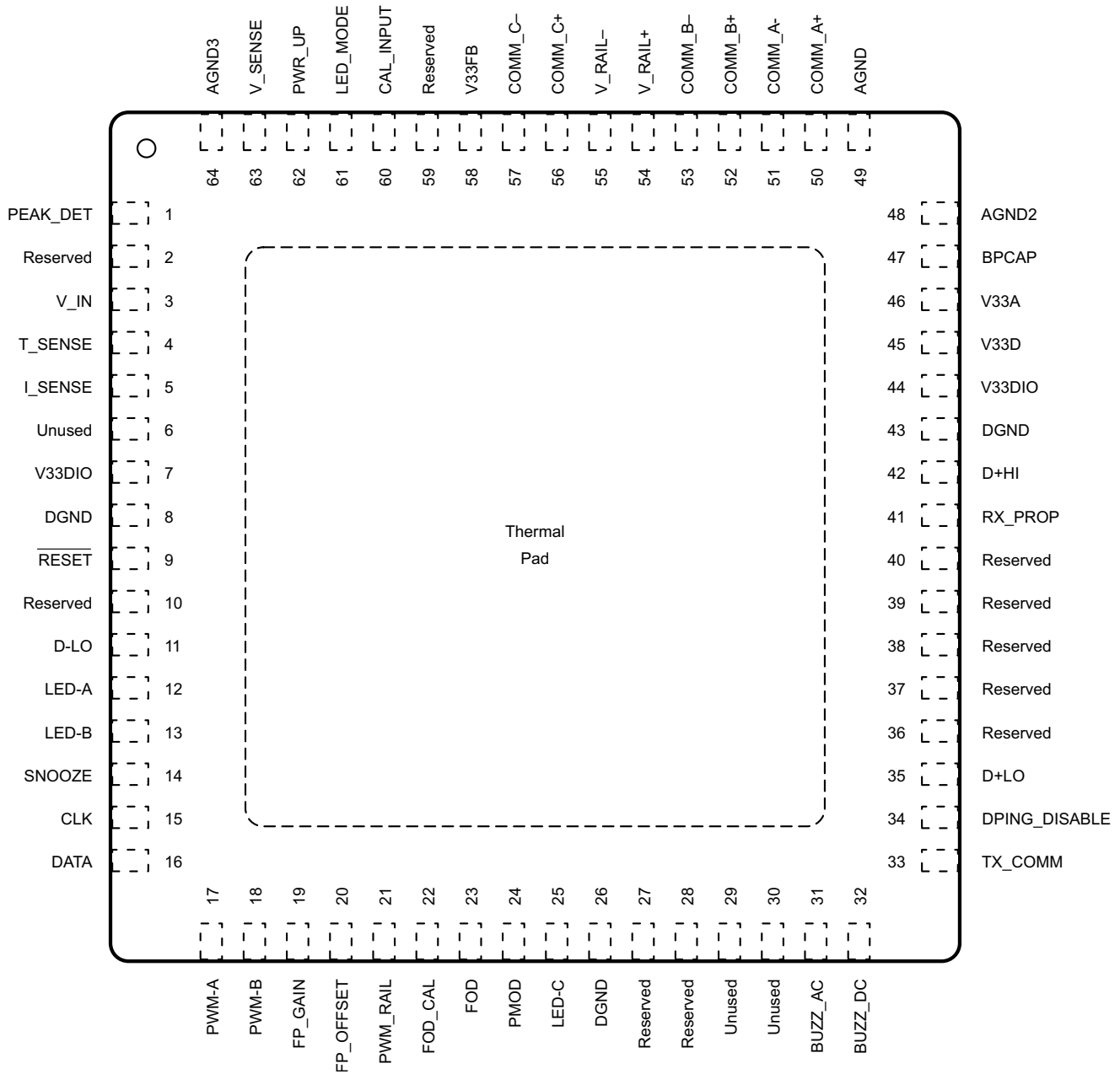

Pin Functions

PIN		I/O	DESCRIPTION
NAME	NO.		
PEAK_DET	1	I	Input from peak detect circuit
Reserved	2	—	This pin must be connected to GND.
V_IN	3	I	Transmitter Input Voltage Sense
T_SENSE	4	I	Sensor input. Device shuts down when below 1 V. If not used, keep above 1 V by simply connecting to 3.3-V supply
I_SENSE	5	I	Full bridge input current sense
Unused	6, 29, 30	—	This pin can be either connected to GND or left open. Connecting to GND can improve layout grounding.
V33DIO	7, 44	—	3.3-V IO power supply
DGND	8, 26, 43	—	GND
RESET	9	I	Device reset. Use 10- to 100-k Ω pullup resistor to 3.3-V supply
Reserved	10	—	This pin must be left open.
D-LO	11	O	HVDCP interface
LED-A	12	O	Connect to an LED with a 470- Ω resistor for status indication.
LED-B	13	O	Connect to an LED with a 470- Ω resistor for status indication.
SNOOZE	14	O	Force SNOOZE (500 ms low power)
CLK	15	I	I ² C interface, Clock
DATA	16	I/O	I ² C interface, Data
PWM-A	17	O	PWM output A, controls one half of the full bridge in a phase-shifted full bridge. Switching dead times must be externally generated.
PWM-B	18	O	PWM output B, controls other half of the full bridge in a phase-shifted full bridge. Switching dead times must be externally generated.
FP_GAIN	19	O	Output to select the FOD ping calibration gain
FP_OFFSET	20	O	Output to select the FOD ping calibration offset
PWM_RAIL	21	O	PWM control signal for full bridge rail voltage
FOD_CAL	22	O	Output to select the FOD calibration
FOD	23	O	Output to select the foreign object detection (FOD) threshold
PMOD	24	O	Output to select the PMOD threshold
LED-C	25	O	Connect to an LED with a 470- Ω resistor for status indication.
Reserved	27, 28	—	This pin can be either connected to GND or left open. Connecting to GND can improve layout grounding.
BUZZ_AC	31	O	AC buzzer output. A 400-ms, 4-kHz AC pulse train when charging begins
BUZZ_DC	32	O	DC buzzer output. A 400-ms DC pulse when charging begins. This could also be connected to an LED with a 470- Ω resistor.
TX_COMM	33	O	Debug only. This pin echoes all TX_COMM
DPING_DISABLE	34	I	Disable periodic ping backup
D+LO	35	O	HVDCP interface
Reserved	36, 37, 38, 39	—	These pins must be left open.
Reserved	40	—	Reserved, connect to 10-k Ω resistor to GND
RX_PROP	41	O	Indicates RX proprietary packet received
D+HI	42	O	HVDCP interface
V33D	45	—	Digital core 3.3-V supply. Be sure to decouple with bypass capacitors as close to the part as possible.
V33A	46	—	Analog 3.3-V supply. This pin can be derived from V33D supply, decouple with 22- Ω resistor and additional bypass capacitors.
BPCAP	47	—	Connect to 1uF bypass capacitors to 3.3-V supply and GND
AGND2	48	—	GND
AGND	49	—	GND

Pin Functions (continued)

PIN		I/O	DESCRIPTION
NAME	NO.		
COMM_A+	50	I	Digital demodulation non-inverting input A. Connect parallel to input B+
COMM_A-	51	I	Digital demodulation inverting input A. Connect parallel to input B-
COMM_B+	52	I	Digital demodulation non-inverting input B. Connect parallel to input A+
COMM_B-	53	I	Digital demodulation inverting input B. Connect parallel to input A-
V_RAIL+	54	I	Feedback for full bridge rail voltage control +
V_RAIL-	55	I	Feedback for full bridge rail voltage control -
COMM_C+	56	I	Digital demodulation non-inverting input C. Connect parallel to input A+
COMM_C-	57	I	Digital demodulation inverting input C. Connect parallel to input A-
V33FB	58	I	Reserved, leave this pin open
Reserved	59	—	This pin must be connected to GND.
CAL_INPUT	60	I	Input for FOD configuration
LED_MODE	61	I	LED mode select
PWR_UP	62	I	First power-up indicator (pull high if unused)
V_SENSE	63	I	Transmitter rail voltage sense
AGND3	64	—	GND
PAD	--	—	Flood with copper GND plane and stitch vias to PCB internal GND plane

7 Specifications

7.1 Absolute Maximum Ratings⁽¹⁾

over operating free-air temperature (unless otherwise noted)

	MIN	MAX	UNIT
Voltage applied at V33D to DGND	-0.3	3.8	V
Voltage applied at V33A to AGND	-0.3	3.8	
Voltage applied to any pin ⁽²⁾	-0.3	3.8	
Storage temperature, T _{stg}	-40	150	°C

- (1) Stresses beyond those listed under *Absolute Maximum Ratings* may cause permanent damage to the device. These are stress ratings only and functional operation of the device at these or any other conditions beyond those indicated under *Recommended Operating Conditions* is not implied. Exposure to absolute-maximum-rated conditions for extended periods may affect device reliability.
- (2) All voltages referenced to GND.

7.2 ESD Ratings

			MAX	UNIT
V _(ESD)	Electrostatic discharge	Human body model (HBM), per ANSI/ESDA/JEDEC JS-001, all pins ⁽¹⁾	±2000	V
		Charged device model (CDM), per JEDEC specification JESD22-C101, all pins ⁽²⁾	±750	

- (1) JEDEC document JEP155 states that 500-V HBM allows safe manufacturing with a standard ESD control process.
- (2) JEDEC document JEP157 states that 250-V CDM allows safe manufacturing with a standard ESD control process.

7.3 Recommended Operating Conditions

over operating free-air temperature range (unless otherwise noted)

		MIN	NOM	MAX	UNIT
V	Supply voltage during operation, V33D, V33A	3.0	3.3	3.6	V
T _A	Operating free-air temperature range	-40		85	°C
T _J	Junction temperature			125	

7.4 Thermal Information

THERMAL METRIC ⁽¹⁾		bq501210	UNIT
		RGC (VQFN)	
		64 Pins	
R _{θJA}	Junction-to-ambient thermal resistance	29.5	°C/W
R _{θJC(top)}	Junction-to-case (top) thermal resistance	15.1	°C/W
R _{θJB}	Junction-to-board thermal resistance	8.4	°C/W
ψ _{JT}	Junction-to-top characterization parameter	0.2	°C/W
ψ _{JB}	Junction-to-board characterization parameter	8.3	°C/W
R _{θJC(bot)}	Junction-to-case (bottom) thermal resistance	1.2	°C/W

- (1) For more information about traditional and new thermal metrics, see the [Semiconductor and IC Package Thermal Metrics](#) application report.

7.5 Electrical Characteristics

over operating free-air temperature range (unless otherwise noted)

PARAMETER		TEST CONDITIONS	MIN	TYP	MAX	UNIT
SUPPLY CURRENT						
I_{V33A}	Supply current	$V33A = 3.3\text{ V}$		8	15	mA
I_{V33D}		$V33D = 3.3\text{ V}$		44	55	
I_{Total}		$V33D = V33A = 3.3\text{ V}$		52	70	
EXTERNALLY SUPPLIED 3.3 V POWER						
V33D	Digital 3.3-V power	$T_A = 25^\circ\text{C}$	3		3.6	V
V33A	Analog 3.3-V power	$T_A = 25^\circ\text{C}$	3		3.6	
V33Slew	3.3-V slew rate	3.3-V slew rate between 2.3 and 2.9 V, $V33A = V33D$	0.25			V/ms
DIGITAL DEMODULATION INPUTS: COMM_A+, COMM_A-, COMM_B+, COMM_B-, COMM_C+, COMM_C-						
V_{CM}	Common mode voltage each pin		-0.15		1.631	V
COMM+, COMM-	Modulation voltage digital resolution			1		mV
R_{EA}	Input Impedance	Ground reference	0.5	1.5	3	$M\Omega$
I_{OFFSET}	Input offset current	1-k Ω source impedance	-5		5	μA
ANALOG INPUTS: V_SENSE, I_SENSE, T_SENSE, LED_MODE, CAL_INPUT, V_IN						
V_{ADC_OPEN}	Voltage indicating open pin	LED_MODE, CAL_INPUT open	2.37			V
V_{ADC_SHORT}	Voltage indicating pin shorted to GND	LED_MODE, CAL_INPUT shorted to ground			0.36	
V_{ADC_RANGE}	Measurement range for voltage monitoring	All analog inputs	0		2.5	
INL	ADC integral nonlinearity		-2.5		2.5	mV
I_{ikg}	Input leakage current	3 V applied to pin			100	nA
R_{IN}	Input impedance	Ground reference	8			$M\Omega$
C_{IN}	Input capacitance				10	pF
DIGITAL INPUTS/OUTPUTS						
V_{OL}	Low-level output voltage	$I_{OL} = 6\text{ mA}$, $V33D = 3\text{ V}$			DGND1 + 0.25	V
V_{OH}	High-level output voltage	$I_{OH} = -6\text{ mA}$, $V33D = 3\text{ V}$	$V33D - 0.6$		V	
V_{IH}	High-level input voltage	$V33D = 3\text{ V}$	2.1		3.6	
V_{IL}	Low-level input voltage	$V33D = 3.5\text{ V}$			1.4	
$I_{OH(MAX)}$	Output high-source current				4	mA
$I_{OL(MAX)}$	Output low-sink current				4	
SYSTEM PERFORMANCE						
V_{RESET}	Voltage where device comes out of reset	V33D pin			2.4	V
t_{RESET}	Pulse duration needed for reset	\overline{RESET} pin	2			μs
f_{SW}	Switching frequency (wireless power transfer)	System input power at startup	> 6 V	130		kHz
			< 6 V	110		
			< 6 V, HVDACP to 9 or 12 V	130		
t_{detect}	Time to detect presence of device requesting power				0.5	s
Writes	Number of nonvolatile erase/write cycles	$T_J = 25^\circ\text{C}$	20			k cycles
PWM RAIL						
f_{SW_RAIL}	Switching frequency			$4 * f_{SW}$		kHz

7.6 Typical Characteristics

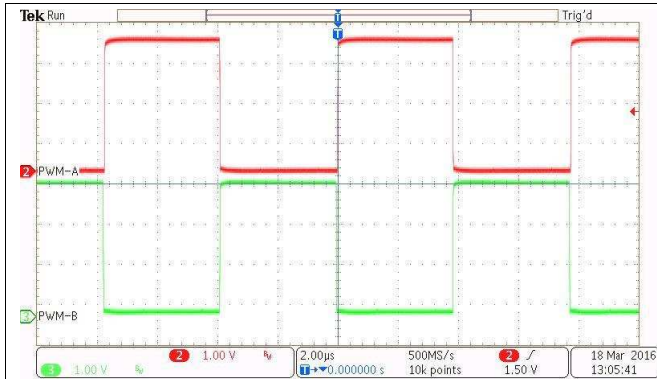

CH2 = PWM-A (1 V / Division)
CH3 = PWM-B (1 V / Division)

Figure 1. Typical PWM-A and PWM-B Signals

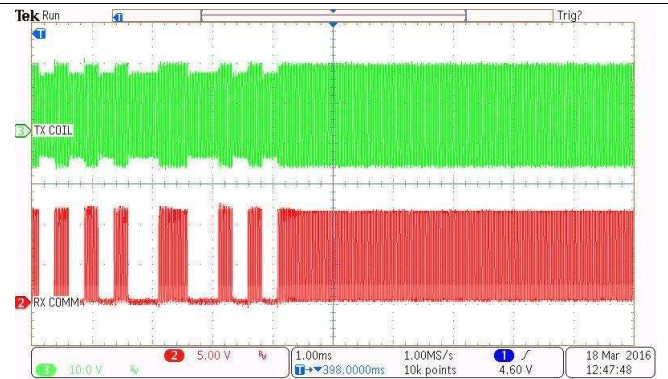

CH2 = RX communication signal (5 V / Division)
CH3 = TX coil voltage (10 V / Division)

Figure 2. TX Coil and RX Communication Signals With RX No Load

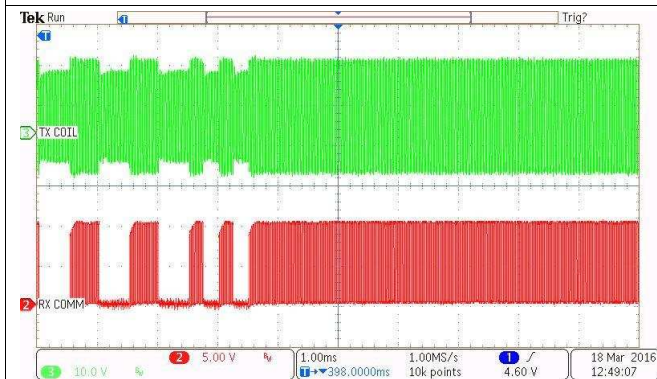

CH2 = RX communication signal (5 V / Division)
CH3 = TX coil voltage (10 V / Division)

Figure 3. TX Coil and RX Communication Signals With RX 5-W Load

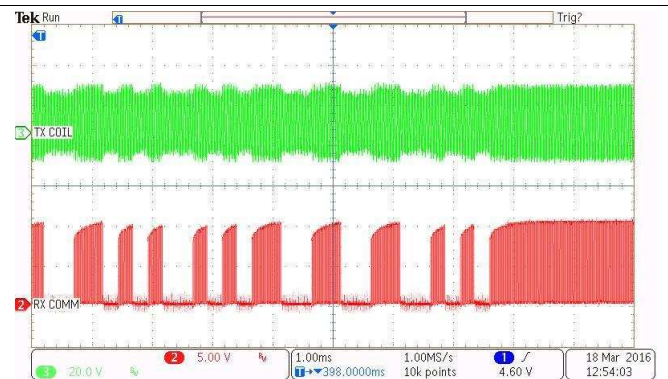

CH2 = RX communication signal (5 V / Division)
CH3 = TX coil voltage (20 V / Division)

Figure 4. TX Coil and RX Communication Signals With RX 15-W Load

8 Detailed Description

8.1 Overview

The principle of wireless power transfer is simply an open-cored transformer consisting of transmitter and receiver coils. The transmitter coil and electronics are typically built into a charger pad and the receiver coil and electronics are typically built into a portable device, such as a cell phone. When the receiver coil is positioned on the transmitter coil, magnetic coupling occurs when the transmitter coil is driven. The flux is coupled into the secondary coil, which induces a voltage and current flows. The secondary voltage is rectified, and power can be transferred effectively to a load, wirelessly. Power transfer can be managed through any of the various closed-loop control schemes.

After power is applied and the device comes out of reset, it can automatically begin the process of detecting and powering a receiver. The bq501210 sends a ping to detect the presence of a receiver on the pad. After a receiver is detected, the bq501210 attempts to establish communication and begin power transfer. If the transmitter detects a v1.2 medium power WPC compliant receiver, it negotiates a maximum power with the receiver and provides the requested power (up to 15 W). If the transmitter detects the bq51025 receiver through its proprietary authentication protocol, the transmitter allows 10-W operation. If a standard 5-W WPC compliant receiver is detected, the transmitter allows 5-W of delivered power as per WPC specification. The bq501210 controls a full-bridge power stage to drive the primary coil. It regulates the power being delivered to the receiver by modulating the supply voltage of the power stage while operating at a constant frequency. The full bridge power stage allows for higher power delivery for a given supply voltage.

8.2 Functional Block Diagram

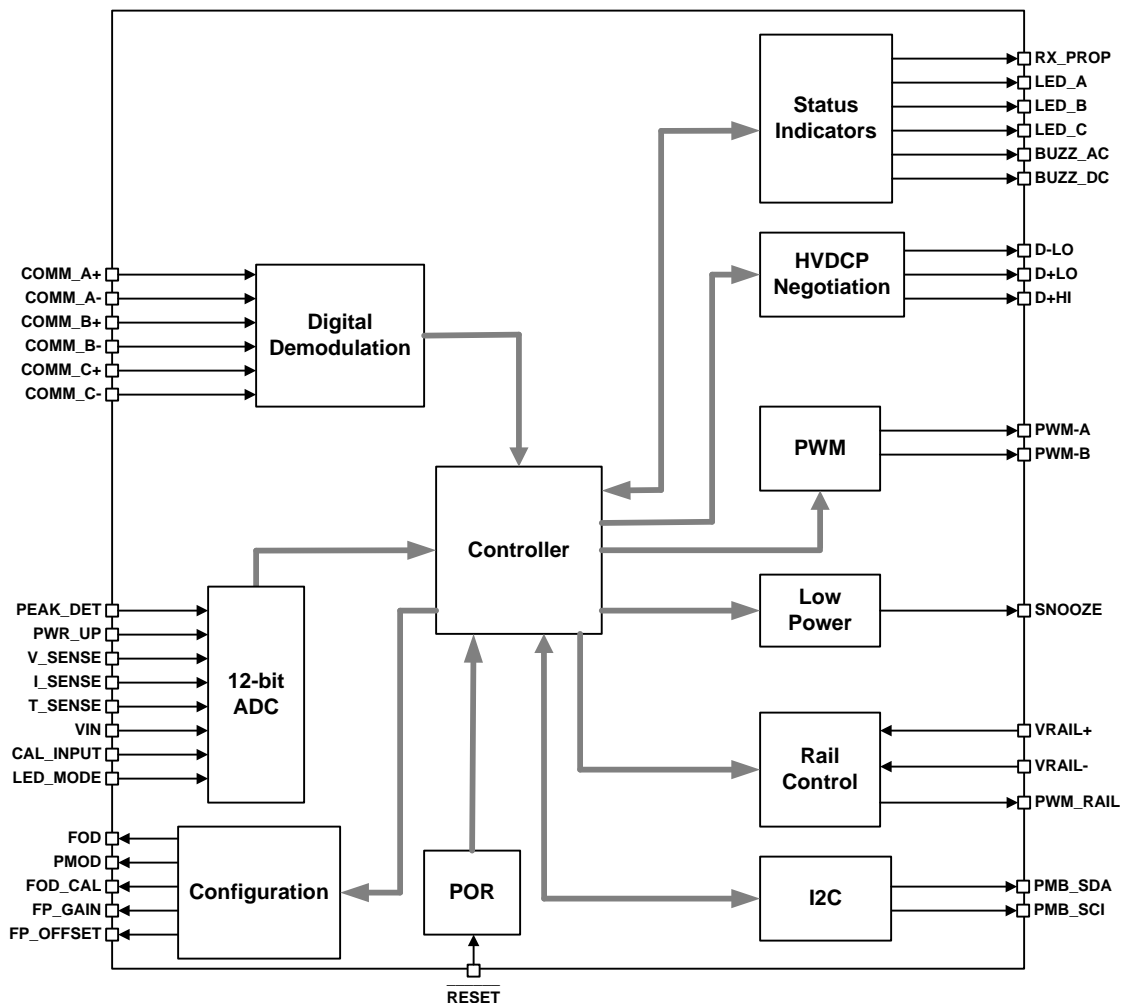

Copyright © 2016, Texas Instruments Incorporated

8.3 Feature Description

8.3.1 MP-A5 Coil Specification

The bq501210 controller supports MP-A5 TX coil type. The coil and matching capacitor specification for MP-A5 transmitter has been established by the WPC Standard. This is fixed and cannot be changed on the transmitter side.

For a current list of coil vendors, see *bqTESLA Transmitter Coil Vendors*, [SLUA649](#).

8.3.2 High Voltage Dedicated Charging Port (HVDCP) Negotiation

If the system input voltage is detected to be < 6 V at startup, the bq501210 attempts to negotiate for higher input voltage.

8.3.3 Fast Charge Support

The bq501210 attempts to negotiate with receiver devices supporting Fast Charge operation to provide additional power for rapid charging.

8.3.4 Option Select Pins

There are two option select pins (pin 60, CAL_INPUT, and pin 61, LED_MODE) on the bq501210 and five selector outputs (pins 19, 20, 22, 23, and 24) used to read multiple voltage thresholds. All the pin voltages will be read by bq501210 at power-up.

- Pin 60 (CAL_INPUT) is used to program the FOD algorithms.
- Pin 61 (LED_MODE) is used to select the LED mode of the device.
- Pins 19, 20, 22, 23, and 24 are used to sequentially bias the five programming resistors shown in [Figure 5](#).

At power-up, a bias current is applied to pins LED_MODE and CAL_INPUT, and the resulting voltage is measured to identify the value of the attached programming resistor. For LED_MODE, the selected bin determines the LED behavior based on [Table 3](#). For the CAL_INPUT, the FP_GAIN, FP_OFFSET, FOD_CAL, FOD and PMOD pins are biased sequentially to measure each pins resistance. The selected bin sets various calibration parameters based on [Table 1](#). See [FOD and Parasitic Metal Object Detect \(PMOD\) Calibration](#) for more information.

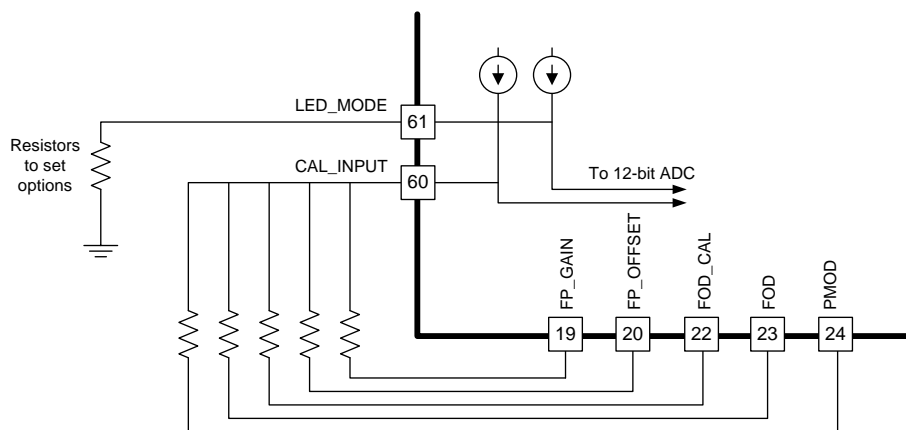

Figure 5. Pin Connections for CAL_INPUT and LED_MODE

8.3.5 FOD and Parasitic Metal Object Detect (PMOD) Calibration

The bq501210 supports multiple levels of protection against heating metal objects placed in the magnetic field. An initial analysis of the impulse response to a short ping (FOD ping) detects most metal objects before any power transfer is initiated. If a foreign metallic object is detected by the FOD ping, an FOD warning is issued (see [Table 3](#)) for up to 6 seconds after the object is removed. If a potential foreign object is detected, the bq501210 transmitter will postpone the FOD determination until the receiver sends the WPC standard "FOD Status Packet" during WPC v1.2 negotiations. After power transfer has started, improved FOD (WPC v1.2) and enhanced

Feature Description (continued)

PMOD (WPC v1.0) features continuously monitor input power, known losses, and the value of power reported by the RX device being charged. Using these inputs, the bq501210 can estimate how much power is unaccounted for and presumed lost due to metal objects placed in the wireless power transfer path. If this unexpected loss exceeds the threshold set by the FOD or PMOD resistors, a fault is indicated and power transfer is halted. The ID packet of the receiver being charged determines whether the FOD or PMOD algorithm is used. The ultimate goal of the FOD feature is safety, to protect misplaced metal objects from becoming hot. Reducing the loss threshold and making the system too sensitive leads to false trips and a bad user experience. Find the balance which best suits the application. If the application requires disabling one function or the other (or both), it is possible by leaving the respective FOD/PMOD terminal open. For example, to selectively disable the PMOD function, PMOD should be left open. A final level of protection is provided with an optional temperature sensor to detect any large increase in temperature in the system (see [Shut Down Through External Thermal Sensor or Trigger](#)).

NOTE

Disabling FOD results in a TX solution that is not WPC v1.1 or WPC v1.2 compliant.

Resistors of 1% tolerance should be used for a reliable selection of the desired threshold. Resistors on the FOD and PMOD pins program the permitted power loss for the FOD and PMOD algorithms respectively. The FOD_CAL resistor can be used to compensate for any load-dependent effect on the power loss. Using a calibrated FOD reference receiver with no foreign objects present, the FOD_CAL resistor should be selected such that the calculated loss across the load range is substantially constant (within approximately 100 mW). After correcting for the load dependence, the FOD and PMOD thresholds should be re-set above the resulting average by approximately 400 mW for the transmitter to satisfy the WPC requirements on tolerated heating.

Contact TI for the TX tuning tool to set appropriate FOD, PMOD, and FOD_CAL resistor values for your design.

Table 1. Option Select Bins

Bin Number	Resistance (k Ω)	Loss Threshold (mW)
0	<36.5	250
1	42.2	300
2	48.7	350
3	56.2	400
4	64.9	450
5	75.0	500
6	86.6	550
7	100	600
8	115	650
9	133	700
10	154	750
11	178	800
12	205	850
13	>237	Feature disabled

8.3.6 FOD Ping Calibration

The bq501210 is able to detect most metal objects in the charging pad by analyzing the impulse response to a short ping (FOD ping) sent before any power transfer is initiated. The bq501210 does this analysis by measuring the change in resonant frequency and decay of the pulse response and comparing it to given threshold values that are set by resistor in FP_GAIN and FP_OFFSET pins.

Resistors of 1% tolerance should be used for a reliable selection of the desired threshold. The FP_GAIN and FP_OFFSET resistors program the boundary conditions to determine if a receiver or a metal object is detected. The recommended resistor value for both FP_GAIN and FP_OFFSET pins is 86.6 kΩ.

Contact TI for inquiries regarding FOD ping calibration.

NOTE

Removing resistors from FP_OFFSET and FP_GAIN pins disables FOD ping and hence foreign object detection prior to power transfer. The Received Power calibration relies on this detection, and thus, the FOD ping is required for WPC v1.2 Medium Power transmitter designs.

8.3.7 Shut Down Through External Thermal Sensor or Trigger

Typical applications of the bq501210 do not require additional thermal protection. This shutdown feature is provided for enhanced applications and is not limited to thermal shutdown. The key parameter is the 1-V threshold on the T_SENSE pin. A voltage below 1 V on T_SENSE causes the device to shut down.

The application of thermal monitoring through a negative temperature coefficient (NTC) sensor, for example, is straightforward. The NTC forms the lower leg of a temperature-dependant voltage divider. The NTC leads are connected to the bq501210 device between T_SENSE and GND. The threshold on T_SENSE is set to 1 V, below which the system shuts down and a fault is indicated (depending on LED mode chosen).

To implement this feature follow these steps:

1. Consult the NTC data sheet and find the resistance versus temperature curve.
2. Determine the actual temperature where the NTC will be placed by using a thermal probe.
3. Read the NTC resistance at that temperature in the NTC data sheet, that is R_NTC.
4. Use the following formula to determine the upper leg resistor (R_Setpoint):

$$R_Setpoint = 2.3 \times R_NTC \quad (1)$$

The system restores normal operation after approximately five minutes or if the receiver is removed. If the feature is not used, this pin must be pulled high (typically to V33A).

NOTE

T_SENSE must always be terminated; otherwise, erratic behavior may occur.

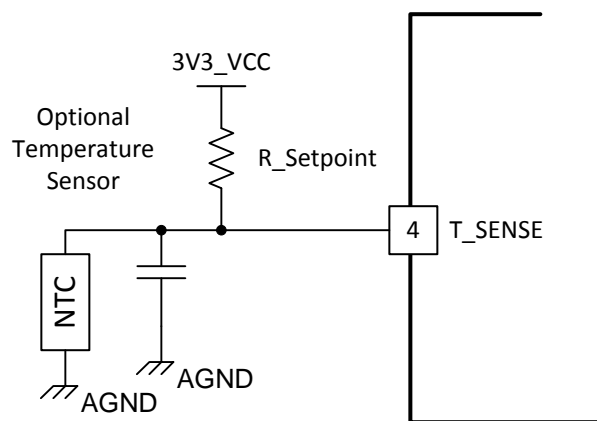

Figure 6. NTC Application

8.3.8 Fault Handling and Indication

Table 2 shows end power transfer (EPT) packet responses, fault conditions, and the duration of how long the condition lasts until a retry is attempted. The LED mode selected determines how the LED indicates the condition or fault.

Table 2. Fault Handling and Indication

CONDITION	TYPICAL DURATION ⁽¹⁾ (BEFORE RETRY)	HANDLING
EPT-00	Immediate ⁽²⁾	Unknown
EPT-01	up to 5 seconds ⁽³⁾	Charge complete
EPT-02	Infinite	Internal fault
EPT-03	5 minutes	Over temperature
EPT-04	Immediate ⁽²⁾	Over voltage
EPT-05	Immediate ⁽²⁾	Over current
EPT-06	Infinite	Battery failure
EPT-07	Not applicable	Reserved
EPT-08	Immediate ⁽²⁾	No response
EPT-09	Not applicable	Reserved
EPT-0A	Immediate	Negotiation Failure
EPT-0B	Immediate	Restart Power Transfer
OVP (over voltage)	Immediate ⁽²⁾	
OC (over current)	1 minute	
NTC (external sensor)	5 minutes	
PMOD/FOD warning	6 seconds	0 to 4 seconds LED only, 4 to 6 seconds LED + AC and DC buzzers
PMOD/FOD	5 minutes	

- (1) After a FAULT, the magnetic field is recharacterized to improve the ability to detect the removal of the at-fault receiver. If the receiver is removed in the first second immediately following the detection of this fault (before the re-characterization is complete), the field corresponding to an empty pad may be associated with the faulty receiver and the LED indication may continue to indicate a fault state even though no receiver is present. This indication persists until either the HOLDOFF time expires or a new receiver disturbs the field, at which time normal operation, with proper LED indication, is resumed.
- (2) Immediate is <1 s.
- (3) The TX may retry immediately (<1 s) to start power after first EPT-01 is received. If the receiver is continuously sending EPT-01, the TX holdoff time will be 5 seconds

8.3.9 Power Transfer Start Signal

The bq501210 features two signal outputs to indicate that power transfer has begun. BUZZ_AC outputs a 400-ms duration, 4-kHz square wave for driving low cost AC type ceramic buzzers. BUZZ_DC outputs logic high, also for 400-ms, which is suitable for DC type buzzers with built-in tone generators, or as a trigger for any type of customized indication scheme. Do not exceed 4-mA loading from either of these pins which is more than adequate for small signaling and actuation. If not used, these pins should be left open.

8.3.10 Power-On Reset

The bq501210 has an integrated power-on reset (POR) circuit which monitors the supply voltage and handles the correct device startup sequence. Additional supply voltage supervisor or reset circuits are not needed.

8.3.11 External Reset, $\overline{\text{RESET}}$ Pin

The bq501210 can be forced into a reset state by an external circuit connected to the $\overline{\text{RESET}}$ pin. A logic low voltage on this pin holds the device in reset. For normal operation, this pin is pulled up to 3.3-V supply (V33A) with a 10-k Ω pullup resistor.

8.3.12 Trickle Charge and CS100

The WPC specification provides an EPT message (EPT-01) to indicate charge complete. Upon receipt of the charge complete message, the bq501210 disables the output and changes the LED indication. The exact indication depends on the LED_MODE chosen.

In some battery charging applications, there is a benefit to continue the charging process in trickle-charge mode to top off the battery. The WPC specification provides for an informational 'Charge Status' packet that conveys the level of battery charger. The bq501210 uses this command to enable top-off charging. The bq501210 changes the LED indication to reflect charge complete when a Charge Status message is 100% received, but unlike the response to an EPT, it will not halt power transfer while the LED indicates charge complete. The mobile device can use a CS100 packet to enable trickle charge mode.

If the reported charge status drops below 90%, normal charging indication is resumed.

8.4 Device Functional Modes

8.4.1 LED Modes

The bq501210 can directly drive three LED outputs (LED-A, LED-B, and LED-C, refer to the table in [Pin Configuration and Functions](#)) through a simple current limit resistor (typically 475 Ω), based on the mode selected. The three current limit resistors can be individually adjusted to tune or match the brightness of the LEDs. Do not exceed the maximum output current rating of the device.

The selection resistor, connected between pin 61 and GND, selects one of the desired LED indication schemes presented in [Table 3](#). Note that some options require fewer LEDs to implement than others.

Table 3. LED Modes

LED CONTROL OPTION	LED SELECTION RESISTOR	LED	OPERATIONAL STATES					
			STANDBY	POWER TRANSFER	CHARGE COMPLETE	FAULT	FOD Warning	High Power Transfer ⁽¹⁾
0	<36.5 kΩ	LED_A	LED CONTROL OPTION 0 disables SNOOZE - Used in system debug only.					
		LED_B						
		LED_C						
1	42.2 kΩ	LED_A	Off	Blink slow ⁽²⁾	On	Off	Off	Blink fast ⁽³⁾
		LED_B	Off	Off	Off	On	Blink fast ⁽³⁾	Off ⁽³⁾
		LED_C	—	—	—	—	—	—
2	48.7 kΩ	LED_A	On	Blink slow ⁽²⁾	On	Off	Off	Blink fast ⁽³⁾
		LED_B	On	Off	Off	On	Blink fast ⁽³⁾	Off ⁽³⁾
		LED_C	—	—	—	—	—	—
3 ⁽⁴⁾	56.2 kΩ	LED_A	Off	On	Off	Blink fast ⁽³⁾	On	On
		LED_B	—	—	—	—	—	—
		LED_C	—	—	—	—	—	—
4	64.9 kΩ	LED_A	Off	On	Off	Off	Off	On
		LED_B	Off	Off	Off	On	Blink fast ⁽³⁾	Off
		LED_C	—	—	—	—	—	—
5	75 kΩ	LED_A	Off	Off	On	Off	Off	Off
		LED_B	Off	On	Off	Off	On	On
		LED_C	Off	Off	Off	Blink slow ⁽²⁾	Off	Off
6	86.6 kΩ	LED_A	Off	Blink slow ⁽²⁾	On	Off	Off	Blink fast ⁽³⁾
		LED_B	Off	Off	Off	On	Blink fast ⁽³⁾	Off
		LED_C	Off	Off	Off	Off	Off	Off
7	100 kΩ	LED_A	Off	Blink slow ⁽²⁾	Off	Off	Off	Blink fast ⁽³⁾
		LED_B	Off	Off	On	Off	Off	Off
		LED_C	Off	Off	Off	On	Blink fast ⁽³⁾	Off
8	115 kΩ	LED_A	Off	Off	On	Blink slow ⁽²⁾	Off	Off
		LED_B	Off	On	Off	Blink slow ⁽²⁾	On	On
		LED_C	—	—	—	—	—	—
9	133 kΩ	LED_A	Off	Blink slow ⁽²⁾	On	Off	Off	Blink fast ⁽³⁾
		LED_B	Off	OFF	Off	On	Blink fast ⁽³⁾	Off
		LED_C	—	—	—	—	—	—
10	154 kΩ	LED_A	Off	On	Off	Blink fast ⁽³⁾	On	On
		LED_B	Off	Off	On	Off	Off	Off
		LED_C	—	—	—	—	—	—

(1) Power transfer when operating with bq51025 wireless power receiver in 10-W mode.

(2) Blink slow = 0.625 Hz

(3) Blink fast = 2.5 Hz

(4) The indication of the shutdown after an negative temperature coefficient (NTC) event may experience a delay in the rapid LED blinking even though the power transfer has been disabled. The indication delay may persist up to as long as the entire NTC FAULT holdoff time.

8.4.2 Power Transfer

Power transfer depends on coil coupling. Coupling depends on the distance between coils, alignment, coil dimensions, coil materials, number of turns, magnetic shielding, impedance matching, frequency, and duty cycle.

Most importantly, the receiver and transmitter coils must be aligned for best coupling and efficient power transfer. The smaller the space between the coils, the better the coupling.

Shielding is added as a backing to both the transmitter and receiver coils to direct the magnetic field to the coupled zone. Magnetic fields outside the coupled zone do not transfer power. Thus, shielding also serves to contain the fields to avoid coupling to other adjacent system components.

Regulation can be achieved by controlling any one of the coil coupling parameters. However, for WPC v1.2 compatibility, the transmitter-side coils and capacitance are specified and the resonant frequency point is fixed. Power transfer is regulated by changing the supply voltage to the full-bridge power stage; higher voltage delivers more power. Duty cycle remains constant at 50% throughout the power band and frequency also remains constant at 130 kHz.

The WPC standard describes the dimensions, materials of the coils, and information regarding the tuning of the coils to resonance. The value of the inductor and resonant capacitor are critical to proper operation and system efficiency.

8.4.3 Communication

Most communication within the WPC is from the receiver to the transmitter, where the receiver tells the transmitter to send power and how much. To regulate, the receiver must communicate with the transmitter whether to increase or decrease the power level. The receiver monitors the rectifier output and using amplitude modulation (AM), sends packets of information to the transmitter. A packet is comprised of a preamble, a header, the actual message, and a checksum, as defined by the WPC standard.

The receiver sends a packet by modulating an impedance network. This AM signal reflects back as a change in the voltage amplitude on the transmitter coil. The signal is demodulated and decoded by the transmitter-side electronics and the voltage on the inverter is adjusted to close the regulation loop. The bq501210 features internal digital demodulation circuitry.

The modulated impedance network on the receiver can either be resistive or capacitive. [Figure 7](#) shows the resistive modulation approach, where a resistor is periodically added to the load, and the resulting amplitude change in the transmitter voltage. [Figure 8](#) shows the capacitive modulation approach, where a capacitor is periodically added to the load and the resulting amplitude change in the transmitter voltage.

In the WPC v1.2 specification, transmitter to receiver communication is introduced to allow a medium power receiver to negotiate for higher power while maintaining backward compatibility with low power (v1.1) devices.

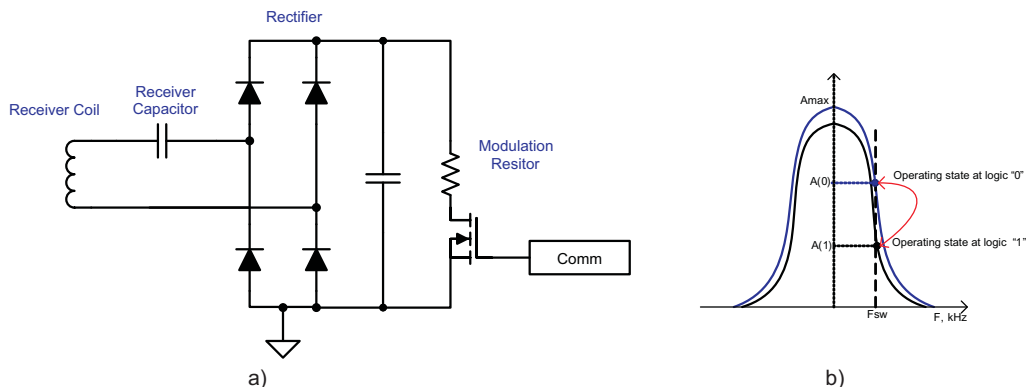

Figure 7. Receiver Resistive Modulation Circuit

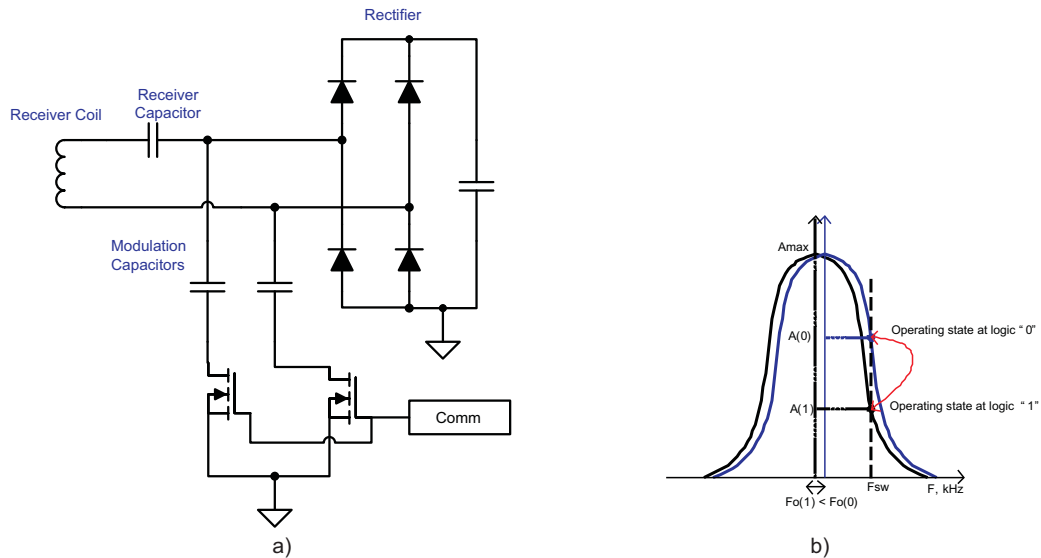

Figure 8. Receiver Capacitive Modulation Circuit

The bq501210 also supports a proprietary handshake with the bq51025 in which minimal communication from the TX to the RX is used. This proprietary handshake enables the bq501210 to deliver power to the bq51025 receiver at levels higher than 5 W. The transmitter-to-receiver communication is achieved through frequency modulation of the power signal.

8.4.4 Power Trains

The bq501210 drives a full-bridge power stage, which drives the coil assembly. TI recommends the bq500101 (SLPS585) as the driver-plus-MOSFET device for this application. The supply voltage (V_{rail}) is controlled by the bq501210 device.

8.4.5 Power Train Voltage Control

The bq501210 controls power delivery by modulating the supply voltage (V_{rail}) of the power stage driving the coil assembly. The bq501210 device generates a PWM control signal in the PWM_RAIL terminal that controls an external power stage circuit (TI recommends bq500101). The switching frequency for this DC-DC controller signal is 520 kHz.

8.4.6 Signal Processing Components

The COMM signal used to control power transfer is derived from the coil voltage. The AC coupled coil voltage is scaled down to a manageable level and biased to a 1-V offset. Series connected diodes are provided for protection from any possible transients.

9 Application and Implementation

NOTE

Information in the following applications sections is not part of the TI component specification, and TI does not warrant its accuracy or completeness. TI's customers are responsible for determining suitability of components for their purposes. Customers should validate and test their design implementation to confirm system functionality.

9.1 Application Information

The bq501210 device is a wireless power transmitter controller designed for 15-W WPC compliant applications and 5-W applications with WPC v1.1 low power receivers. It integrates all functions required to control wireless power transfer to a WPC v1.2 compliant receiver. Several tools are available for the design of the system. See the product folder (www.ti.com/product/bq501210) for more details. The following sections highlight some of the system design considerations.

9.2 Typical Application

Figure 9 shows the application block diagram for the transmitter.

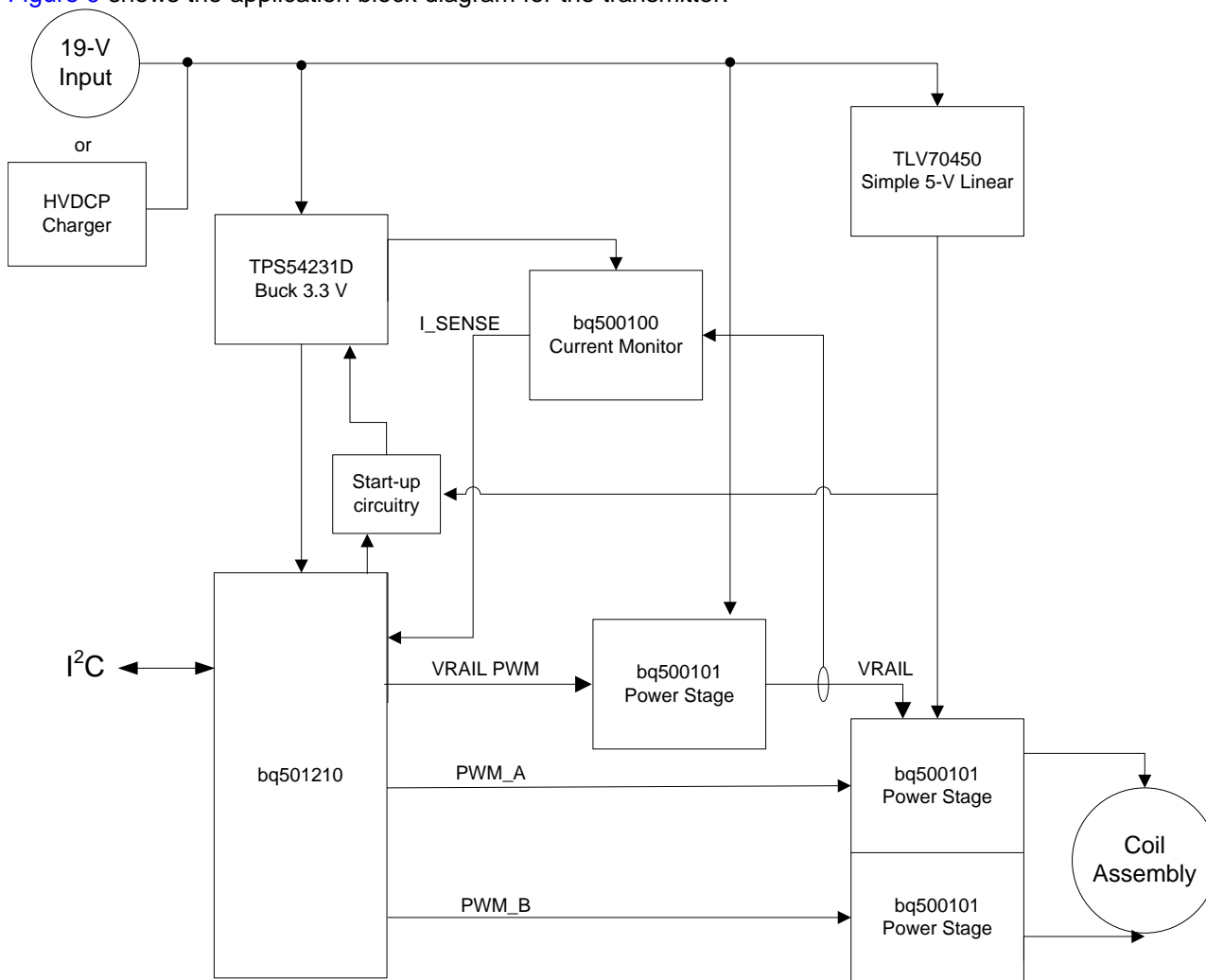

Copyright © 2016, Texas Instruments Incorporated

Figure 9. bq501210 System Diagram

Typical Application (continued)

9.2.1 Design Requirements

Table 4. Design Parameters

DESIGN PARAMETER	VALUE
WPC coil type	MP-A5
Input voltage	15 V to 19 V provides full 15-W operation. HVDCP negotiated 9 V or 12 V provides < 15 W 5 V provides up to 4.5 W

9.2.2 Detailed Design Procedure

9.2.2.1 Capacitor Selection

Capacitor selection is critical to proper system operation. The total capacitance value of $2 \times 100 \text{ nF} + 47 \text{ nF}$ is required in the resonant tank. This is the WPC system compatibility requirement, not a guideline.

NOTE

A total capacitance value of $2 \times 100 \text{ nF} + 47 \text{ nF}$ (C0G dielectric type, 100-V rating) is required in the resonant tank to achieve the correct resonance frequency.

The capacitors chosen must be rated for at least 100 V and must be of a high-quality C0G dielectric (sometimes also called NP0). These are typically available in a 5% tolerance, which is adequate. TI does not recommend the use of X7R types or below if WPC compliance is required because critical WPC Certification Testing, such as the minimum modulation or guaranteed power test, might fail.

The designer can combine capacitors to achieve the desired capacitance value. Various combinations can work depending on market availability. All capacitors must be of C0G types (not mixed with any other dielectric types).

9.2.2.2 Current Monitoring Requirements

The bq501210 is WPC v1.2 ready. To enable the PMOD or FOD features, provide current monitoring in the design.

For proper scaling of the current monitor signal, the current sense resistor should be $20 \text{ m}\Omega$ and the current shunt amplifier should have a gain of 50, such as the bq500100 ([SBOS765](#)). For FOD accuracy, the current sense resistor must be a quality component with 0.5% tolerance, at least 1/4-W rating, and a temperature stability of $\pm 200 \text{ PPM}$. Proper current sensing techniques in the application hardware should also be observed.

9.2.2.3 All Unused Pins

All unused pins can be left open unless otherwise indicated. Refer to the table in [Pin Configuration and Functions](#). To improve PCB layout, ground unused pins, if it is an option.

9.2.2.4 Input Regulators

The bq501210 requires $3.3 \text{ V}_{\text{DC}}$ to operate. A buck converter is used to step down from the supply voltage, such as the TPS54231D used in this design.

9.2.2.5 Input Power Requirements

The bq501210 system works with 5-V to 19-V input voltage. Levels between 15 V and 19 V will deliver 15 W, which is required for a WPC Extended Power Profile (EPP) transmitter.

5-V input supplies are aimed to negotiate to HVDCP voltages of 9 V or 12 V which enables Fast Charging of capable receivers. The system may also deliver power as a normal 5-V transmitter, however, the power level will be reduced and providing power to higher voltage receivers may not be successful. A typical 5-V receiver has shown to produce 4.5 W consistently. Coupling and other factors will greatly influence the results of each system.

9.2.2.6 LED Mode

The bq501210 can directly drive three LED outputs (LED-A, LED-B, and LED-C). Select one of the desired LED indication schemes by choosing the selection resistor connected between LED_MODE and GND.

9.2.3 Application Curves

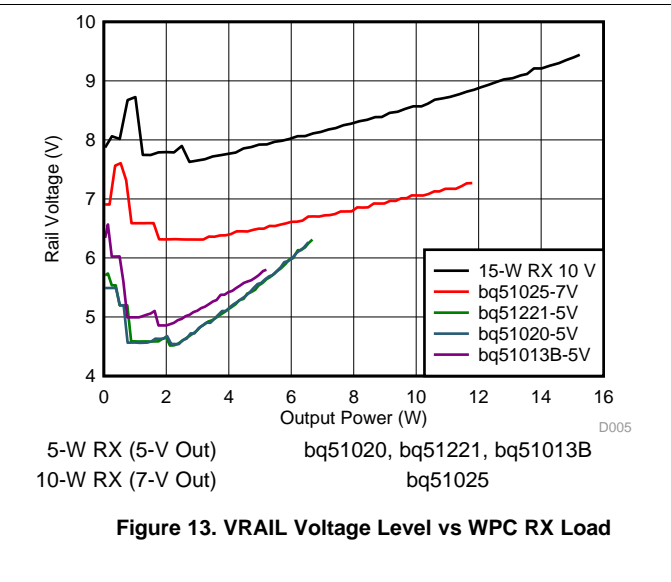
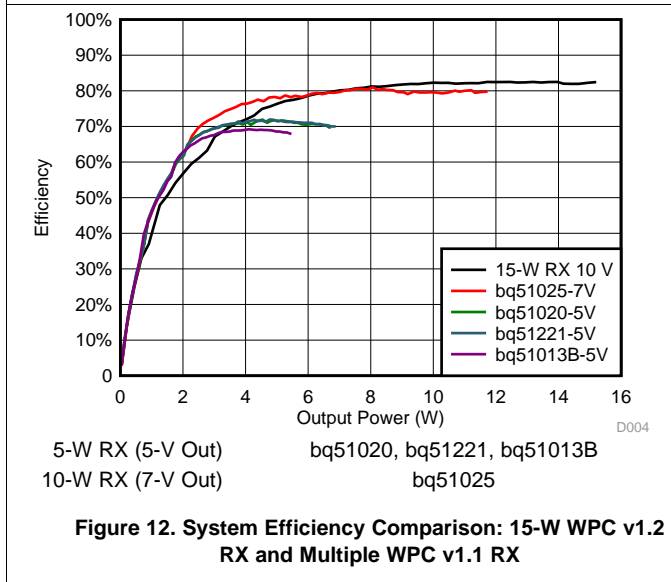
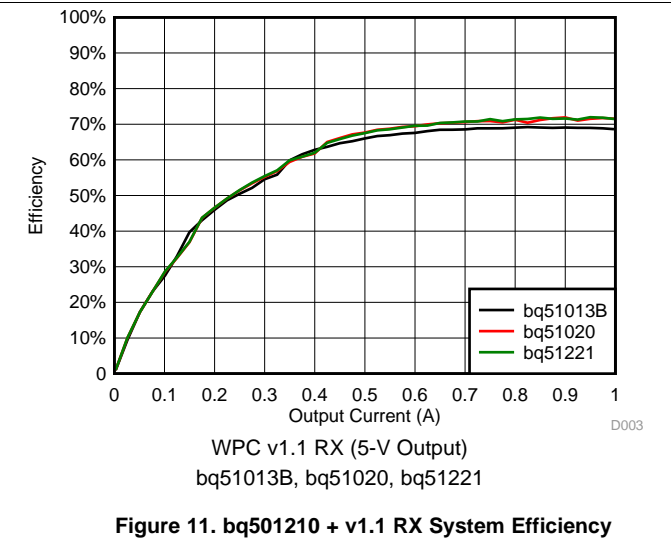
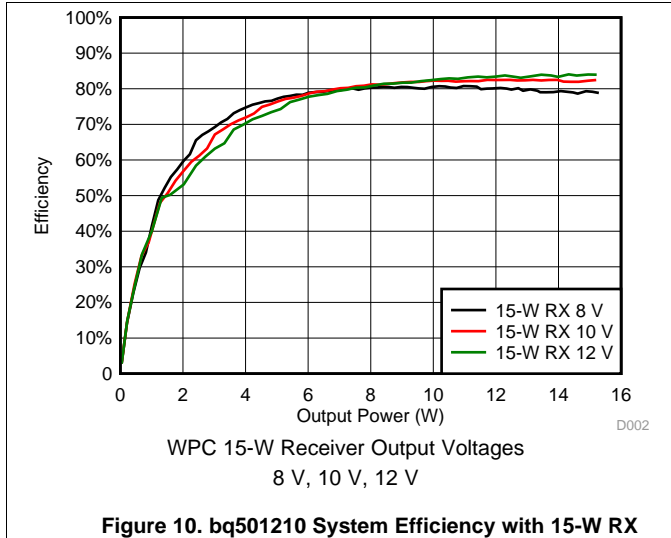

10 Power Supply Recommendations

This device is designed to operate from an input voltage supply range between 3- to 3.6-V, nominal 3.3-V. The design works with 12-V to 19-V input voltage. Levels between 15 V and 19 V will deliver 15 W.

11 Layout

11.1 Layout Guidelines

Careful PCB layout practice is critical to proper system operation. Many references are available on proper PCB layout techniques. A few good tips are as follows:

The TX layout requires a 4-layer PCB layout for best ground plane technique. A 2-layer PCB layout can be achieved though not as easily. Ideally, the approach to the layer stack-up is:

- Layer 1 component placement and as much ground plane as possible
- Layer 2 clean ground
- Layer 3 finish routing
- Layer 4 clean ground

Thus, the circuitry is virtually sandwiched between grounds. This minimizes EMI noise emissions and also provides a noise-free voltage reference plane for device operation.

Keep as much copper as possible. Make sure the bq501210 GND pins and the EPAD GND power pad have a continuous flood connection to the ground plane. The power pad should also be stitched to the ground plane, which also acts as a heat sink for the bq501210. A good GND reference is necessary for proper bq501210 operation, such as analog-digital conversion, clock stability, and best overall EMI performance.

Separate the analog ground plane from the power ground plane and use only **one** tie point to connect grounds. Having several tie points defeats the purpose of separating the grounds.

The COMM return signal from the resonant tank should be routed as a differential pair. This is intended to reduce stray noise induction. The frequencies of concern warrant low-noise analog signaling techniques, such as differential routing and shielding, but the COMM signal lines do not need to be impedance matched.

The DC-DC buck regulator used from the 19-V input supplies the bq501210 with 3.3-V. Typically, the designer uses a single-chip controller solution with integrated power FET and synchronous rectifier or outboard diode. Pull in the buck inductor and power loop as close as possible to create a tight loop. Likewise, the power-train, full-bridge components should be pulled together as tight as possible. See the bq501210EVM-756 for an example of a good layout technique.

11.2 Layout Example

A DC-DC buck regulator is used to step down the system voltage to the 3.3-V supply to the bq501210. The system voltage is 19-V; with such a step-down ratio, switching duty-cycle is low and the regulator is mostly freewheeling. Therefore, place the freewheeling diode current loop as close to the switching regulator as possible and use wide traces. Place the buck inductor and power loop as close to that as possible to minimize current path.

Place 3.3-V buck regulator input bypass capacitors as close as possible to the buck IC.

Layout Example (continued)

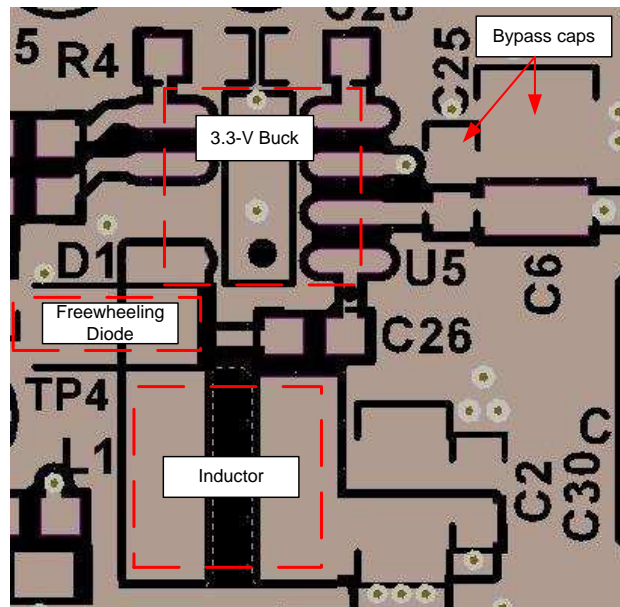

Figure 14. 3.3-V DC-DC Buck Regulator Layout

Make sure the bypass capacitors intended for the bq501210 3.3-V supply are actually bypassing these supply pins (pin 44, V33DIO, pin 45, V33D, and pin 46, V33A) to solid ground plane. This means they need to be placed as close to the device as possible and the traces must be as wide as possible.

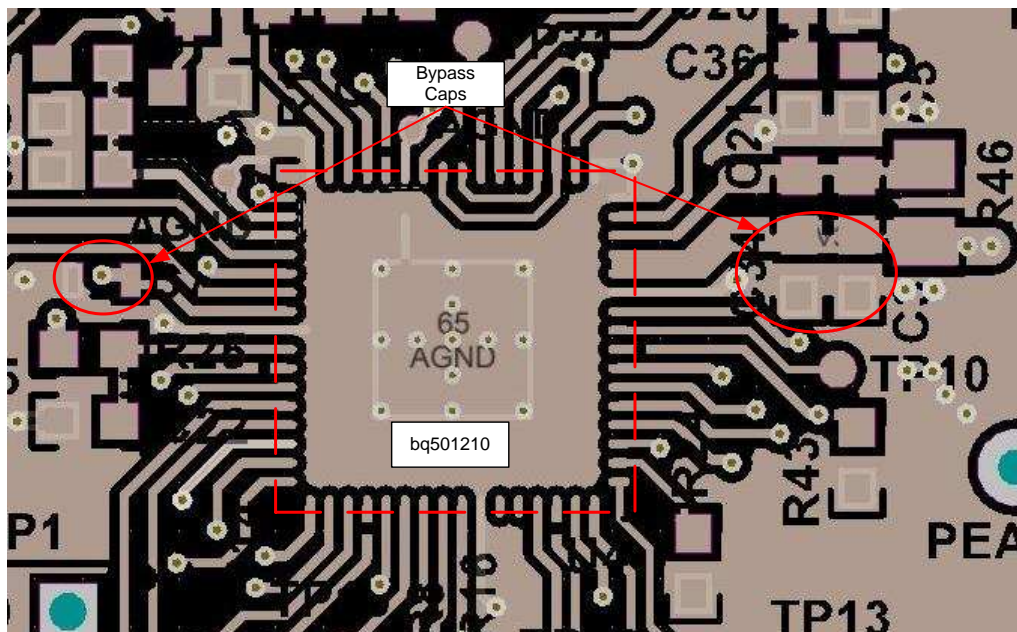

Figure 15. Bypass Capacitors Layout

Layout Example (continued)

Make sure the bq501210 has a continuous flood connection to the ground plane.

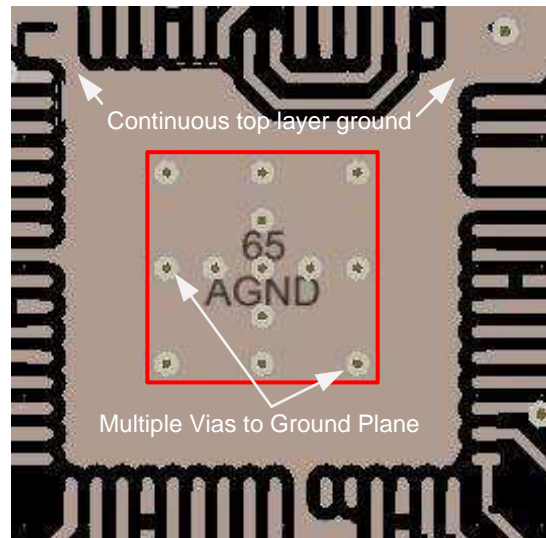

Figure 16. Continuous GND Layout

A buck regulator is used to regulate the supply voltage to the full bridge. The buck power stage IC is controlled by a PWM signal generated by the bq501210 IC, and it is directly powered from the input supply. Because the buck output voltage can operate at a wide voltage range, significant current flow is expected in both the buck power stage input and ground connections. Make sure wide traces and continuous pours are used for input and ground. Place input bypass capacitors, output capacitor and inductor as close as possible to the buck power stage to make the current loop as small as possible.

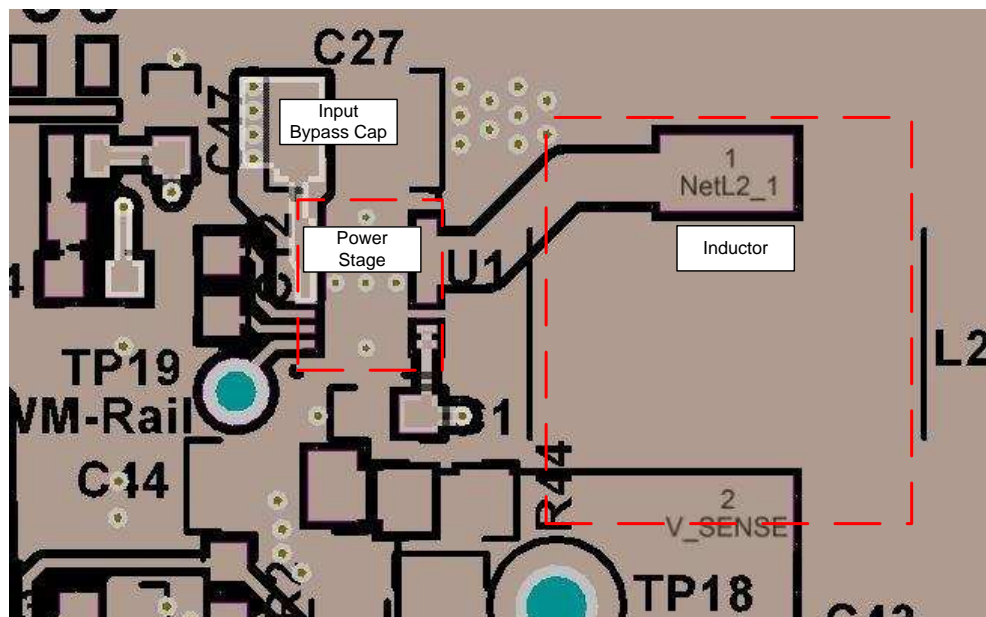

Figure 17. V_RAIL Power Stage Layout

The full-bridge power stage that drives the TX coil is composed of two half-bridge power stages and resonant capacitors. Inputs bypass capacitors should be placed as close as possible to the power stage ICs. The input and ground pours and traces should be made as wide as possible for better current flow. The trace to the coil and resonant capacitors should also be made as wide as possible.

Layout Example (continued)

Proper current sensing layout technique is very important, as it directly affects the FOD and PMOD performance. When sampling the very-low voltages generated across a current sense resistor, be sure to use the so called 4-wire or Kelvin-connection technique. This is important to avoid introducing false voltage drops from adjacent pads and copper power routes. It is a common power-supply layout technique. Some high-accuracy sense resistors have dedicated sense pins.

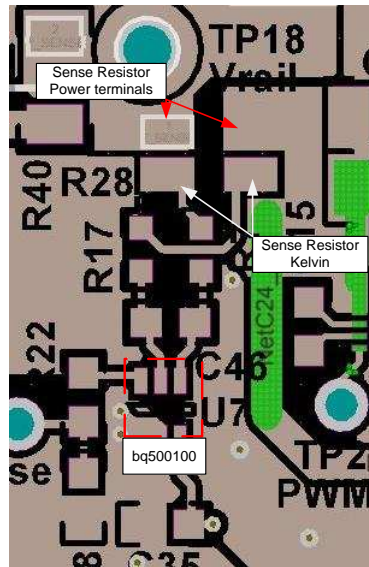

Figure 20. Current Sensing Layout

The COMM+/COMM– sense lines should be run as a balanced or differential pair. For communication, the WPC packet information runs at 2 kHz, which is essentially audio frequency content, and this balancing reduces noise pickup from the surrounding switching power electronics. The designer does not need to tune or impedance-match these lines as would be the case in RF signaling. It is important to keep this lines isolated from any fast switching signal such as PWM, to prevent noise from being injected into the line.

The V_RAIL+/VRAIL– sense lines should also run as differential pair. [Figure 21](#) shows a layout example for a differential pair layout.

Layout Example (continued)

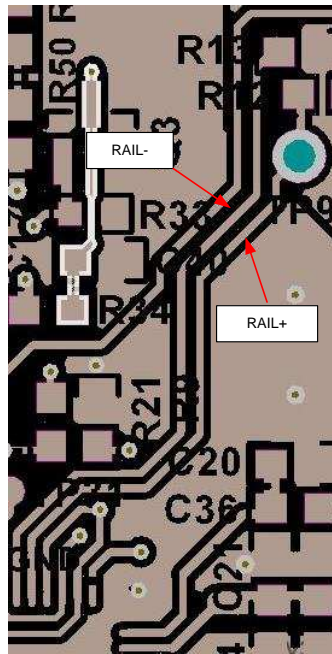

Figure 21. Balanced Differential Signal Layout

A bypass capacitor needs to be connected between the point where the 3.3-V bias supply is connected to the COMM+ resistor divider and the divider/COMM- ground connection.

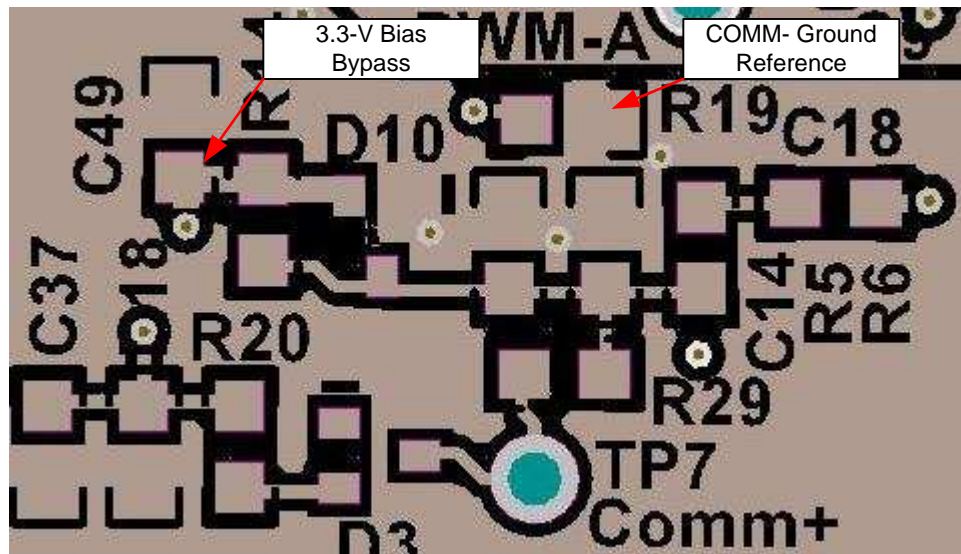

Figure 22. Bypass Capacitors Layout for COMM+ Resistor Divider 3.3-V Bias

12 Device and Documentation Support

12.1 Device Support

1. Technology, *Wireless Power Consortium*, www.wirelesspowerconsortium.com/
2. Data sheet, *bq51025 WPC v1.1 Compliant Single Chip Wireless Power Receiver With Proprietary 10-W Power Delivery*, [SLUSBX7](#)
3. Data sheet, *bq500100 Wireless Charging Current Monitor*, [SBOS765](#)
4. Data sheet, *bq500101 NexFET Power Stage*, [SLPS585](#)
5. Data sheet, *TLV70450 24-V Input Voltage, 150-mA, Ultralow I_Q Low-Dropout Regulators*, [SBVS148](#)
6. Data sheet, *TPS54231 2-A, 28-V Input, Step-Down DC-DC Converter With Eco-mode*, [SLUS851](#)
7. Application note, *Building a Wireless Power Transmitter*, [SLUA635](#)
8. Application note, *bqTESLA Transmitter Coil Vendors*, [SLUA649](#)

12.2 Receiving Notification of Documentation Updates

To receive notification of documentation updates — go to the product folder for your device on ti.com. In the upper right-hand corner, click the *Alert me* button to register and receive a weekly digest of product information that has changed (if any). For change details, check the revision history of any revised document.

12.3 Community Resources

The following links connect to TI community resources. Linked contents are provided "AS IS" by the respective contributors. They do not constitute TI specifications and do not necessarily reflect TI's views; see TI's [Terms of Use](#).

TI E2E™ Online Community *TI's Engineer-to-Engineer (E2E) Community*. Created to foster collaboration among engineers. At e2e.ti.com, you can ask questions, share knowledge, explore ideas and help solve problems with fellow engineers.

Design Support *TI's Design Support* Quickly find helpful E2E forums along with design support tools and contact information for technical support.

12.4 Trademarks

E2E is a trademark of Texas Instruments.

12.5 Electrostatic Discharge Caution



These devices have limited built-in ESD protection. The leads should be shorted together or the device placed in conductive foam during storage or handling to prevent electrostatic damage to the MOS gates.

12.6 Glossary

[SLYZ022](#) — *TI Glossary*.

This glossary lists and explains terms, acronyms, and definitions.

13 Mechanical, Packaging, and Orderable Information

The following pages include mechanical, packaging, and orderable information. This information is the most current data available for the designated devices. This data is subject to change without notice and revision of this document. For browser-based versions of this data sheet, refer to the left-hand navigation.

PACKAGING INFORMATION

Orderable Device	Status (1)	Package Type	Package Drawing	Pins	Package Qty	Eco Plan (2)	Lead/Ball Finish (6)	MSL Peak Temp (3)	Op Temp (°C)	Device Marking (4/5)	Samples
BQ501210RGCR	NRND	VQFN	RGC	64	3000	Green (RoHS & no Sb/Br)	NIPDAU	Level-3-260C-168 HR	-40 to 85	BQ501210	
BQ501210RGCT	NRND	VQFN	RGC	64	250	Green (RoHS & no Sb/Br)	NIPDAU	Level-3-260C-168 HR	-40 to 85	BQ501210	

(1) The marketing status values are defined as follows:

ACTIVE: Product device recommended for new designs.

LIFEBUY: TI has announced that the device will be discontinued, and a lifetime-buy period is in effect.

NRND: Not recommended for new designs. Device is in production to support existing customers, but TI does not recommend using this part in a new design.

PREVIEW: Device has been announced but is not in production. Samples may or may not be available.

OBSELETE: TI has discontinued the production of the device.

(2) **RoHS:** TI defines "RoHS" to mean semiconductor products that are compliant with the current EU RoHS requirements for all 10 RoHS substances, including the requirement that RoHS substance do not exceed 0.1% by weight in homogeneous materials. Where designed to be soldered at high temperatures, "RoHS" products are suitable for use in specified lead-free processes. TI may reference these types of products as "Pb-Free".

RoHS Exempt: TI defines "RoHS Exempt" to mean products that contain lead but are compliant with EU RoHS pursuant to a specific EU RoHS exemption.

Green: TI defines "Green" to mean the content of Chlorine (Cl) and Bromine (Br) based flame retardants meet JS709B low halogen requirements of <=1000ppm threshold. Antimony trioxide based flame retardants must also meet the <=1000ppm threshold requirement.

(3) MSL, Peak Temp. - The Moisture Sensitivity Level rating according to the JEDEC industry standard classifications, and peak solder temperature.

(4) There may be additional marking, which relates to the logo, the lot trace code information, or the environmental category on the device.

(5) Multiple Device Markings will be inside parentheses. Only one Device Marking contained in parentheses and separated by a "~" will appear on a device. If a line is indented then it is a continuation of the previous line and the two combined represent the entire Device Marking for that device.

(6) Lead/Ball Finish - Orderable Devices may have multiple material finish options. Finish options are separated by a vertical ruled line. Lead/Ball Finish values may wrap to two lines if the finish value exceeds the maximum column width.

Important Information and Disclaimer:The information provided on this page represents TI's knowledge and belief as of the date that it is provided. TI bases its knowledge and belief on information provided by third parties, and makes no representation or warranty as to the accuracy of such information. Efforts are underway to better integrate information from third parties. TI has taken and continues to take reasonable steps to provide representative and accurate information but may not have conducted destructive testing or chemical analysis on incoming materials and chemicals. TI and TI suppliers consider certain information to be proprietary, and thus CAS numbers and other limited information may not be available for release.

In no event shall TI's liability arising out of such information exceed the total purchase price of the TI part(s) at issue in this document sold by TI to Customer on an annual basis.

TAPE AND REEL INFORMATION



QUADRANT ASSIGNMENTS FOR PIN 1 ORIENTATION IN TAPE



*All dimensions are nominal

Device	Package Type	Package Drawing	Pins	SPQ	Reel Diameter (mm)	Reel Width W1 (mm)	A0 (mm)	B0 (mm)	K0 (mm)	P1 (mm)	W (mm)	Pin1 Quadrant
BQ501210RGCR	VQFN	RGC	64	3000	330.0	16.4	9.3	9.3	1.1	12.0	16.0	Q2
BQ501210RGCT	VQFN	RGC	64	250	180.0	16.4	9.3	9.3	1.1	12.0	16.0	Q2

TAPE AND REEL BOX DIMENSIONS



*All dimensions are nominal

Device	Package Type	Package Drawing	Pins	SPQ	Length (mm)	Width (mm)	Height (mm)
BQ501210RGCR	VQFN	RGC	64	3000	367.0	367.0	38.0
BQ501210RGCT	VQFN	RGC	64	250	210.0	185.0	35.0

GENERIC PACKAGE VIEW

RGC 64

VQFN - 1 mm max height

9 x 9, 0.5 mm pitch

PLASTIC QUAD FLATPACK - NO LEAD

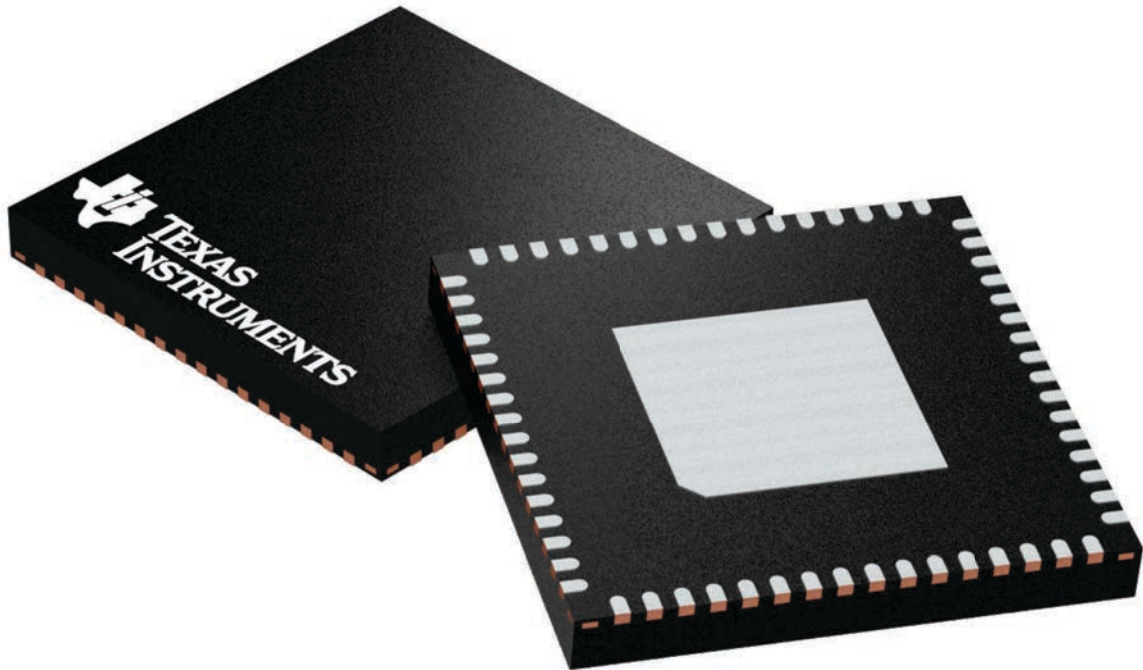

Images above are just a representation of the package family, actual package may vary.
Refer to the product data sheet for package details.

4224597/A

RGC0064B

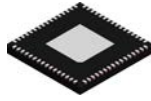

PACKAGE OUTLINE

VQFN - 1 mm max height

PLASTIC QUAD FLATPACK - NO LEAD

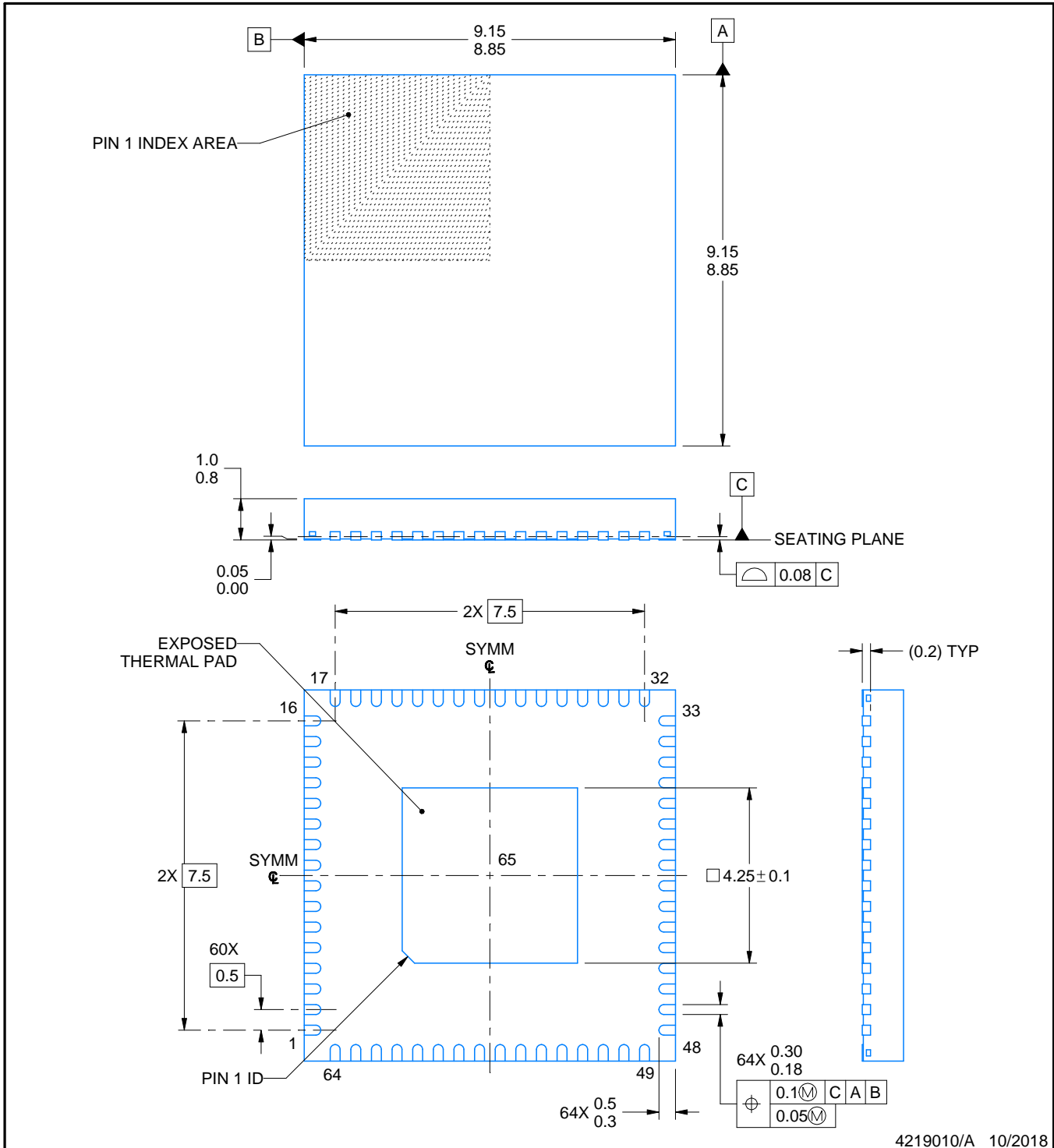

NOTES:

1. All linear dimensions are in millimeters. Any dimensions in parenthesis are for reference only. Dimensioning and tolerancing per ASME Y14.5M.
2. This drawing is subject to change without notice.
3. The package thermal pad must be soldered to the printed circuit board for thermal and mechanical performance.

EXAMPLE BOARD LAYOUT

RGC0064B

VQFN - 1 mm max height

PLASTIC QUAD FLATPACK - NO LEAD

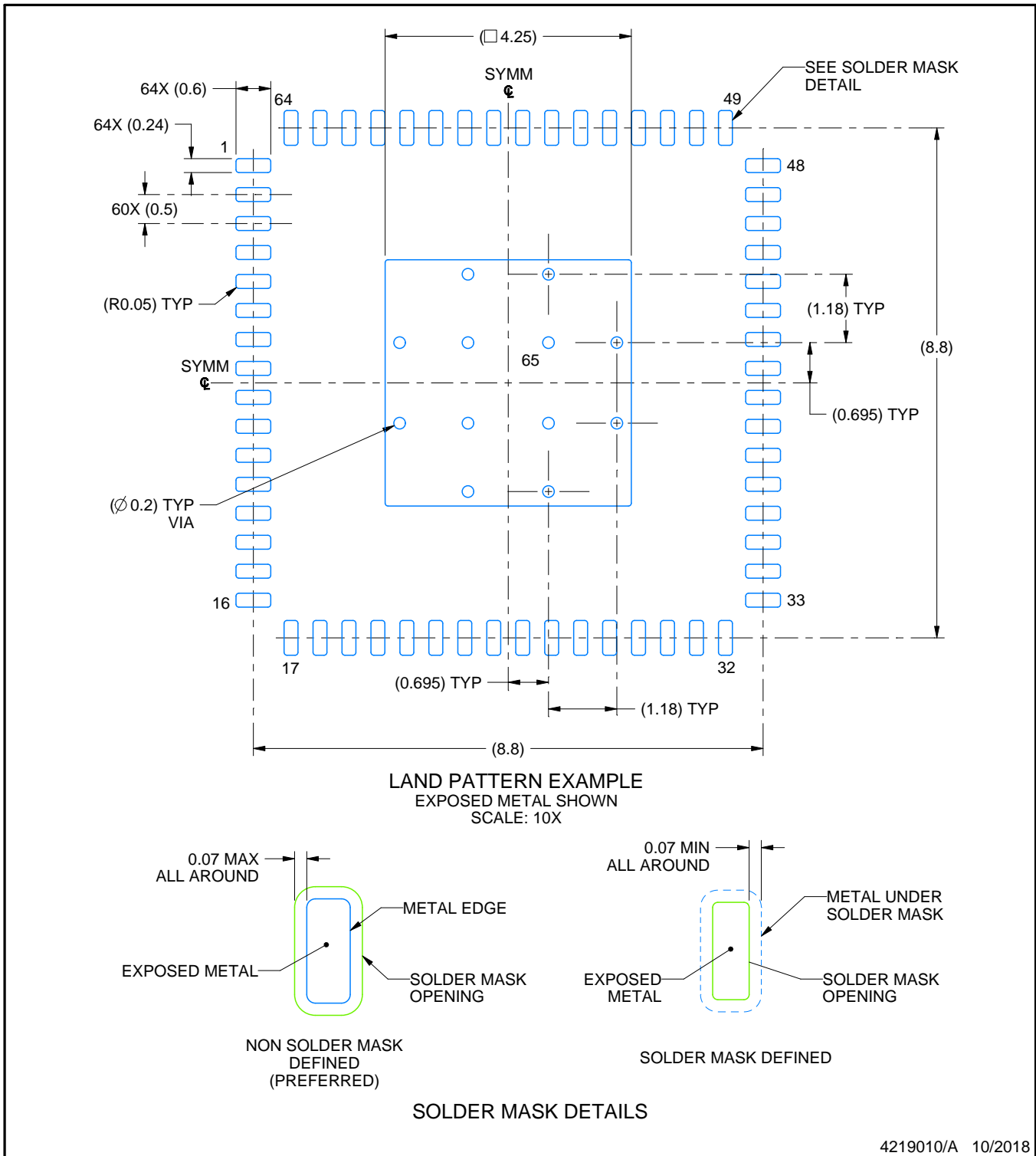

NOTES: (continued)

- This package is designed to be soldered to a thermal pad on the board. For more information, see Texas Instruments literature number SLUA271 (www.ti.com/lit/slua271).
- Vias are optional depending on application, refer to device data sheet. If any vias are implemented, refer to their locations shown on this view. It is recommended that vias under paste be filled, plugged or tented.

EXAMPLE STENCIL DESIGN

RGC0064B

VQFN - 1 mm max height

PLASTIC QUAD FLATPACK - NO LEAD

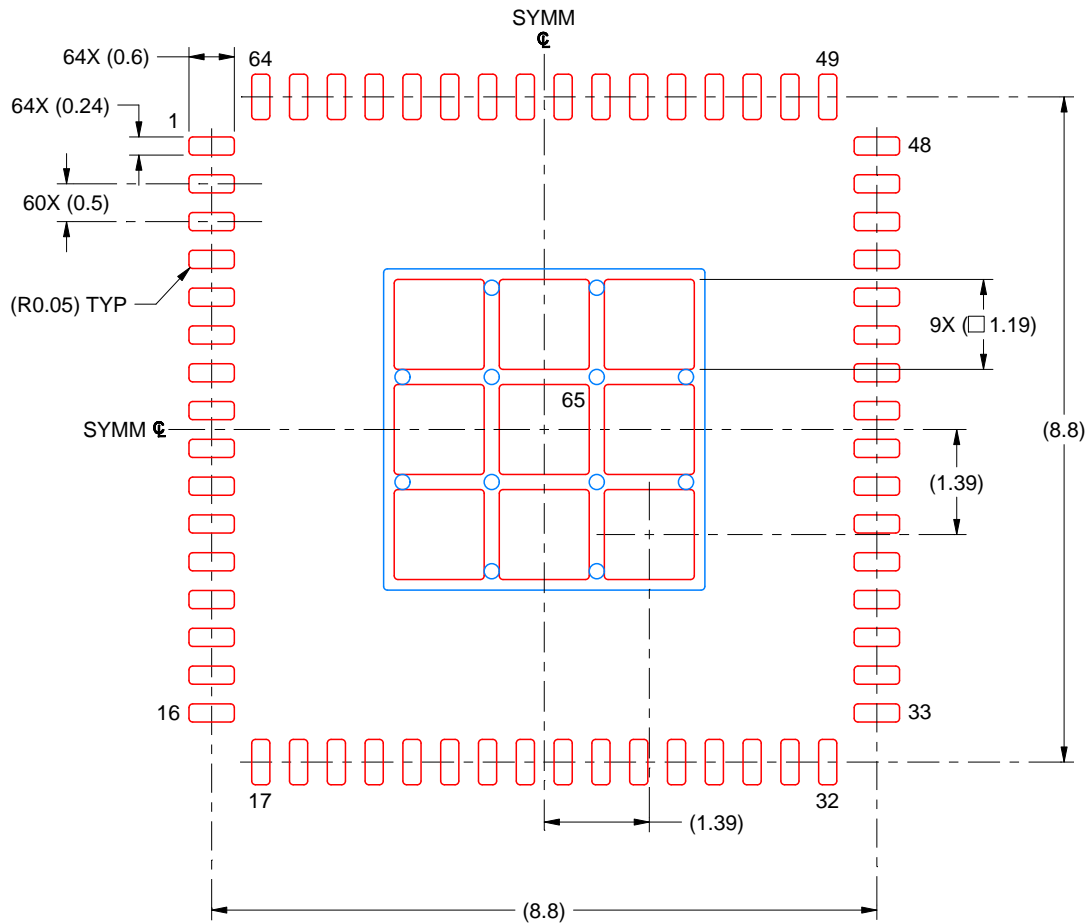

SOLDER PASTE EXAMPLE
BASED ON 0.125 MM THICK STENCIL
SCALE: 10X

EXPOSED PAD 65
71% PRINTED SOLDER COVERAGE BY AREA UNDER PACKAGE

4219010/A 10/2018

NOTES: (continued)

6. Laser cutting apertures with trapezoidal walls and rounded corners may offer better paste release. IPC-7525 may have alternate design recommendations.

IMPORTANT NOTICE AND DISCLAIMER

TI PROVIDES TECHNICAL AND RELIABILITY DATA (INCLUDING DATASHEETS), DESIGN RESOURCES (INCLUDING REFERENCE DESIGNS), APPLICATION OR OTHER DESIGN ADVICE, WEB TOOLS, SAFETY INFORMATION, AND OTHER RESOURCES "AS IS" AND WITH ALL FAULTS, AND DISCLAIMS ALL WARRANTIES, EXPRESS AND IMPLIED, INCLUDING WITHOUT LIMITATION ANY IMPLIED WARRANTIES OF MERCHANTABILITY, FITNESS FOR A PARTICULAR PURPOSE OR NON-INFRINGEMENT OF THIRD PARTY INTELLECTUAL PROPERTY RIGHTS.

These resources are intended for skilled developers designing with TI products. You are solely responsible for (1) selecting the appropriate TI products for your application, (2) designing, validating and testing your application, and (3) ensuring your application meets applicable standards, and any other safety, security, or other requirements. These resources are subject to change without notice. TI grants you permission to use these resources only for development of an application that uses the TI products described in the resource. Other reproduction and display of these resources is prohibited. No license is granted to any other TI intellectual property right or to any third party intellectual property right. TI disclaims responsibility for, and you will fully indemnify TI and its representatives against, any claims, damages, costs, losses, and liabilities arising out of your use of these resources.

TI's products are provided subject to TI's Terms of Sale (www.ti.com/legal/termsofsale.html) or other applicable terms available either on ti.com or provided in conjunction with such TI products. TI's provision of these resources does not expand or otherwise alter TI's applicable warranties or warranty disclaimers for TI products.

Mailing Address: Texas Instruments, Post Office Box 655303, Dallas, Texas 75265
Copyright © 2020, Texas Instruments Incorporated