

## N-channel Power MOSFET

- High ruggedness MOSFET
- $R_{DS(ON)}$  (Typ 0.0068 $\Omega$ )@ $V_{GS}=10V$
- Gate Charge (Typ 65nC)
- Improved dv/dt Capability
- Fast Switching
- 100% Avalanche Tested

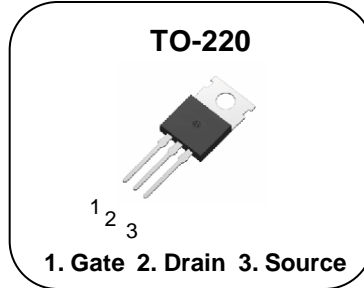

$BV_{DSS}$	: 55[V]
$I_D$	: 110[A]
$R_{DS(ON)}$	: 0.008[ $\Omega$ ]

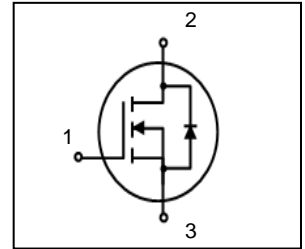

### General Description

This power MOSFET has an excellent avalanche characteristics, and low  $R_{DS(ON)}$  and low gate charge as well by using PowerGate semiconductor's own and specialized design technology, These are well suited for high stress system such like motor control, amplifier, UPS, or DC to DC converter Which needs lower gate charge and on-resistance.

### Absolute maximum ratings

Symbol	Parameter	PFP3205	Unit
$V_{DSS}$	Drain to Source Voltage	55	V
$I_D$	Continuous Drain Current (@ $T_C=25^\circ C$ )	110	A
	Continuous Drain Current (@ $T_C=100^\circ C$ )	80	A
$I_{DM}$	Drain current pulsed (note 1)	390	A
$V_{GS}$	Gate to Source Voltage	$\pm 20$	V
$E_{AS}$	Single pulsed Avalanche Energy (note 2)	2900	mJ
$E_{AR}$	Repetitive Avalanche Energy (note 1)	20	mJ
dv/dt	Peak diode Recovery dv/dt (note 3)	5.0	V/ns
$P_D$	Total power dissipation (@ $T_C=25^\circ C$ )	200	W
	Derating factor above 25 $^\circ C$	1.34	W/ $^\circ C$
$T_{STG}, T_J$	Operating Junction Temperature & Storage Temperature	-55 ~ + 175	$^\circ C$
$T_L$	Maximum Lead Temperature for soldering purpose, 1/8 from Case for 5 seconds.	300	$^\circ C$

### Thermal characteristics

Symbol	Parameter	Typ.	Max.	Unit
$R_{thjc}$	Thermal resistance, Junction to case		0.75	$^\circ C/W$
$R_{thcs}$	Thermal resistance, Case to Sink	0.5		$^\circ C/W$
$R_{thja}$	Thermal resistance, Junction to ambient		62.5	$^\circ C/W$

**Electrical characteristic** (  $T_C = 25^\circ\text{C}$  unless otherwise specified )

Symbol	Parameter	Test conditions	Min.	Typ.	Max.	Unit
<b>Off characteristics</b>						
$BV_{DSS}$	Drain to source breakdown voltage	$V_{GS}=0V, I_D=250\mu A$	55	-	-	V
$\Delta BV_{DSS} / \Delta T_J$	Breakdown voltage temperature coefficient	$I_D=250\mu A$ , referenced to $25^\circ\text{C}$	-	0.05	-	$V/^\circ\text{C}$
$I_{DSS}$	Drain to source leakage current	$V_{DS}=55V, V_{GS}=0V$	-	-	10	$\mu A$
		$V_{DS}=44V, T_C=125^\circ\text{C}$	-	-	125	$\mu A$
$I_{GSS}$	Gate to source leakage current, forward	$V_{GS}=20V, V_{DS}=0V$	-	-	100	nA
	Gate to source leakage current, reverse	$V_{GS}=-20V, V_{DS}=0V$	-	-	-100	nA
<b>On characteristics</b>						
$V_{GS(TH)}$	Gate threshold voltage	$V_{DS}=V_{GS}, I_D=250\mu A$	2.0	-	4.0	V
$R_{DS(ON)}$	Drain to source on state resistance	$V_{GS}=10V, I_D = 62A$			0.008	$\Omega$
<b>Dynamic characteristics</b>						
$C_{iss}$	Input capacitance	$V_{GS}=0V, V_{DS}=25V, f=1\text{MHz}$	-	2675		pF
$C_{oss}$	Output capacitance		-	760		
$C_{rss}$	Reverse transfer capacitance		-	100		
$t_{d(on)}$	Turn on delay time	$V_{DS}=28V, I_D=62A, R_G=25\Omega$	-		36	ns
$t_r$	Rising time		-		150	
$t_{d(off)}$	Turn off delay time		-		70	
$t_f$	Fall time		-		90	
$Q_g$	Total gate charge	$V_{DS}=44V, V_{GS}=10V, I_D=62A$	-	65	150	nC
$Q_{gs}$	Gate-source charge		-		-	
$Q_{gd}$	Gate-drain charge		-		-	

**Source to drain diode ratings characteristics**

Symbol	Parameter	Test conditions	Min.	Typ.	Max.	Unit
$I_S$	Continuous source current	Integral reverse p-n Junction diode in the MOSFET	-	-	110	A
$I_{SM}$	Pulsed source current		-	-	390	A
$V_{SD}$	Diode forward voltage drop.	$I_S=62A, V_{GS}=0V$	-	-	1.4	V
$T_{rr}$	Reverse recovery time	$I_S=62A, V_{GS}=0V,$	-		104	ns
$Q_{rr}$	Breakdown voltage temperature	$di_F/dt=100A/\mu s.$	-		215	nC

**※. Notes**

1. Repetitive rating : pulse width limited by junction temperature.
2.  $L = 200\mu H, I_{AS} = 62.0A, V_{DD} = 25V, R_G=50\Omega$ , Starting  $T_J = 25^\circ\text{C}$
3.  $I_{SD} \leq 110A, di/dt = 300A/\mu s, V_{DD} \leq BV_{DSS}$ , Starting  $T_J = 25^\circ\text{C}$
4. Pulse Test : Pulse Width  $\leq 300\mu s$ , duty cycle  $\leq 2\%$
5. Essentially independent of operating temperature.

**Fig 1. On-State Characteristics**

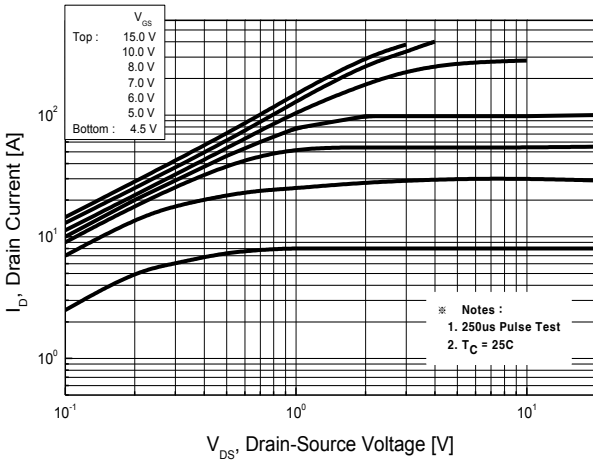

**Fig 2. Transfer Characteristics**

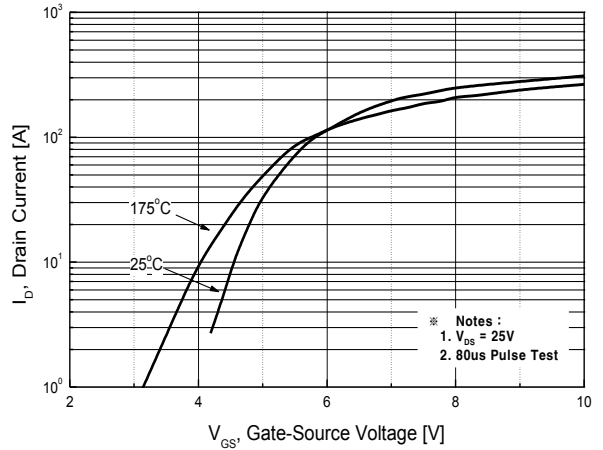

**Fig 3. On State Current vs. Allowable Case Temperature**

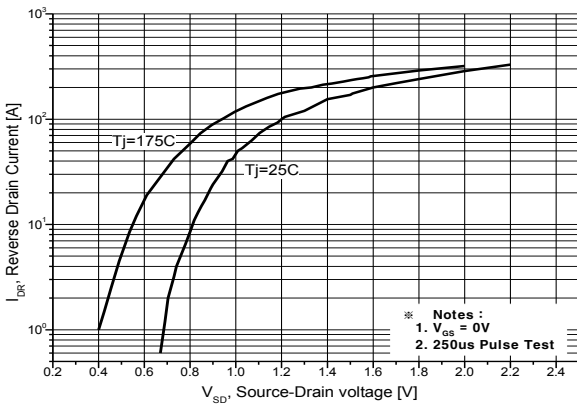

**Fig 4. Capacitance Characteristics**

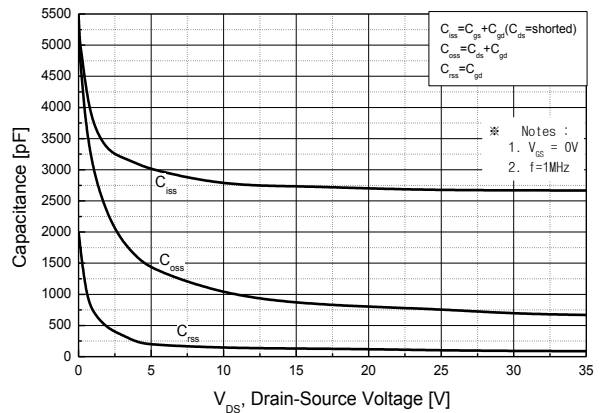

**Fig 5. Gate Charge Characteristics**

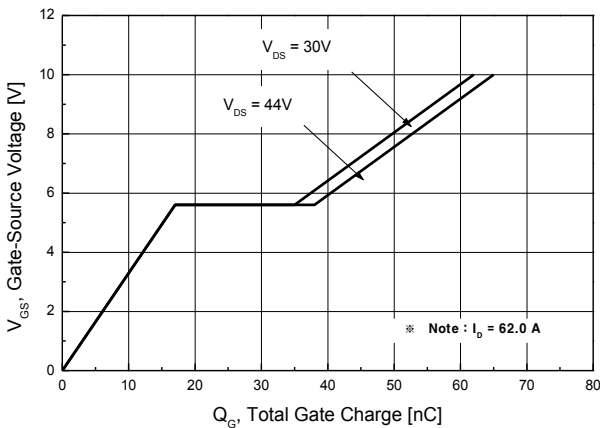

**Fig 6. Maximum Safe Operating Area**

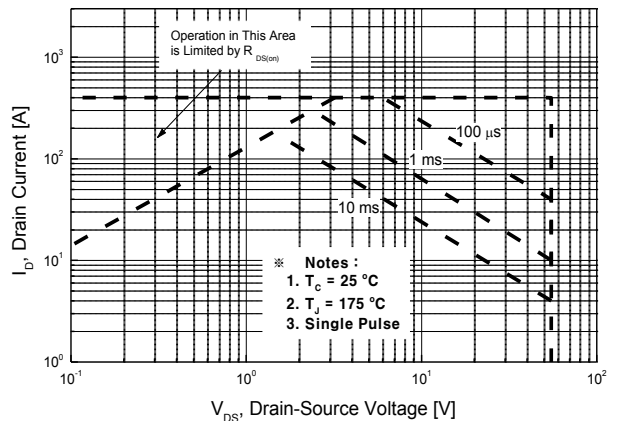

**Fig 7. On-Resistance Variation vs. Junction Temperature**

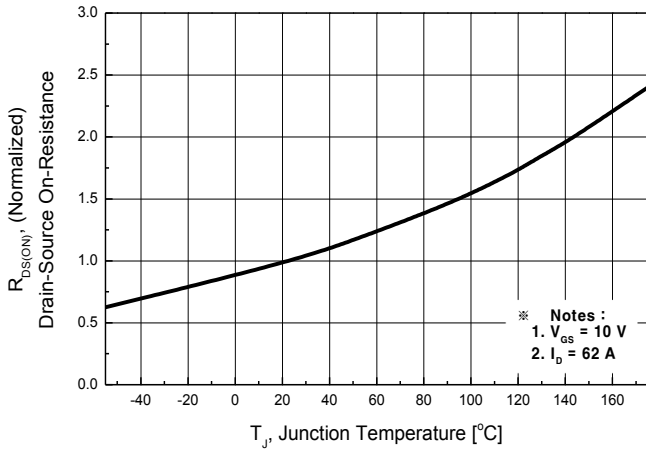

**Fig 8. Maximum Drain Current vs. Case Temperature**

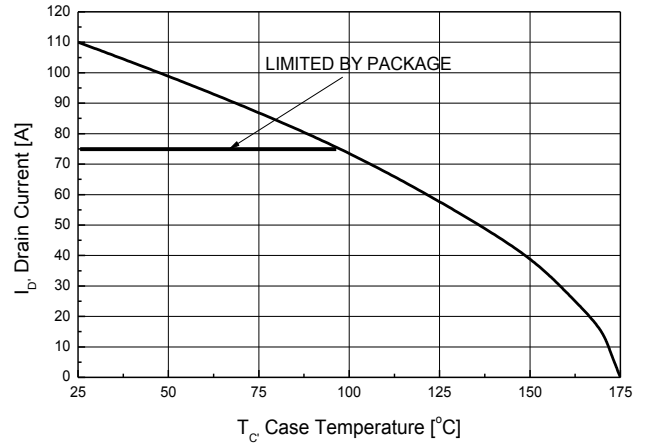

**Fig 9. Transient Thermal Response Curve**

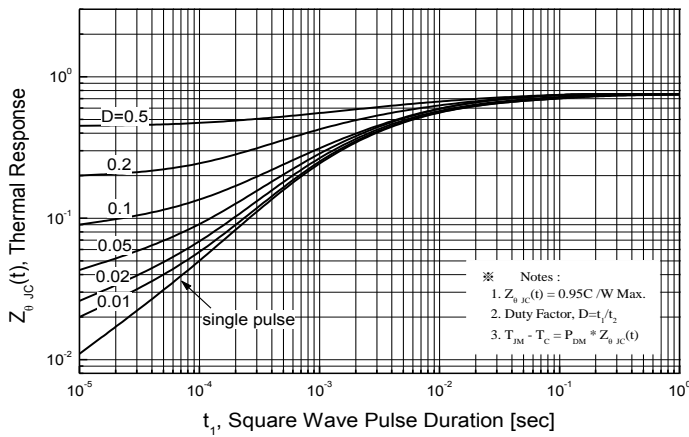

**Fig. 10. Gate charge test circuit & waveform**

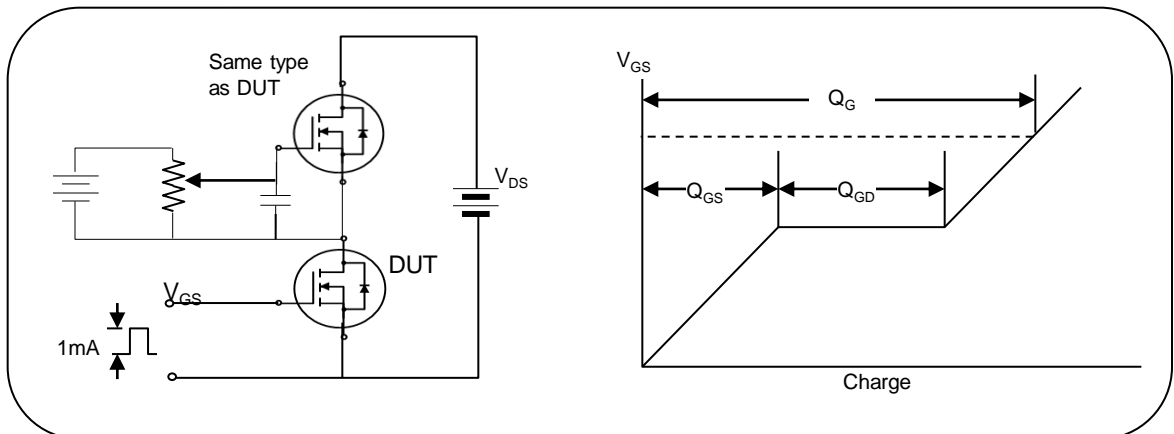

**Fig. 11. Switching time test circuit & waveform**

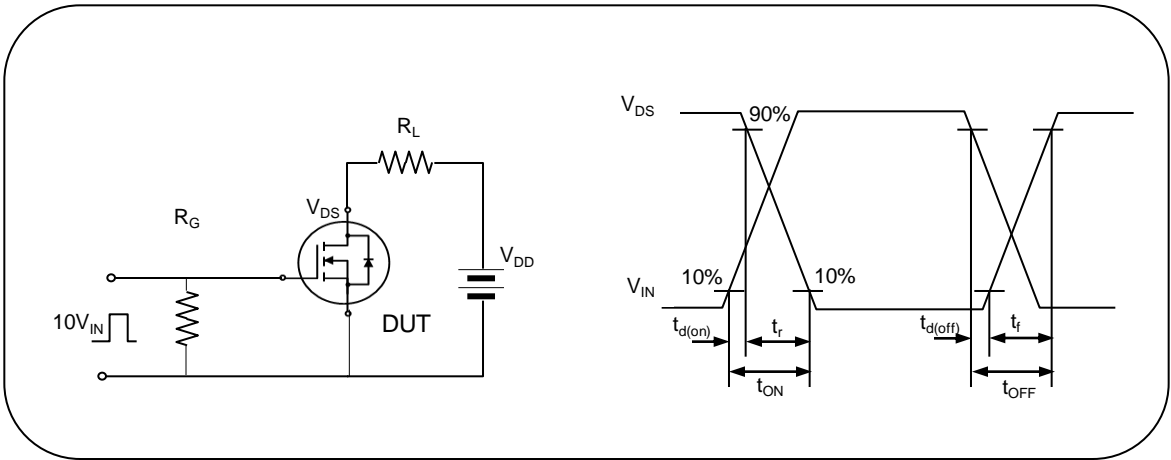

**Fig. 12. Unclamped Inductive switching test circuit & waveform**

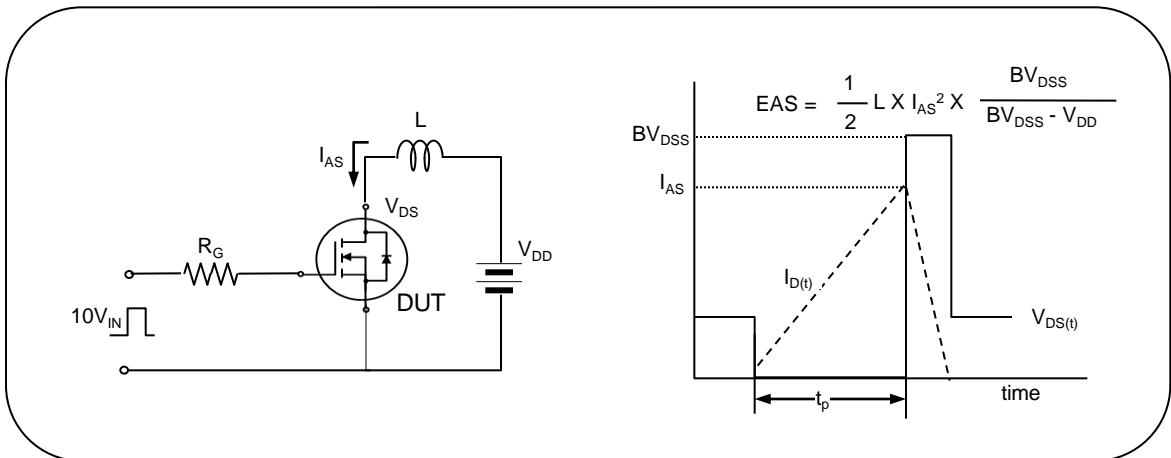

**Fig. 13. Peak diode recovery dv/dt test circuit & waveform**

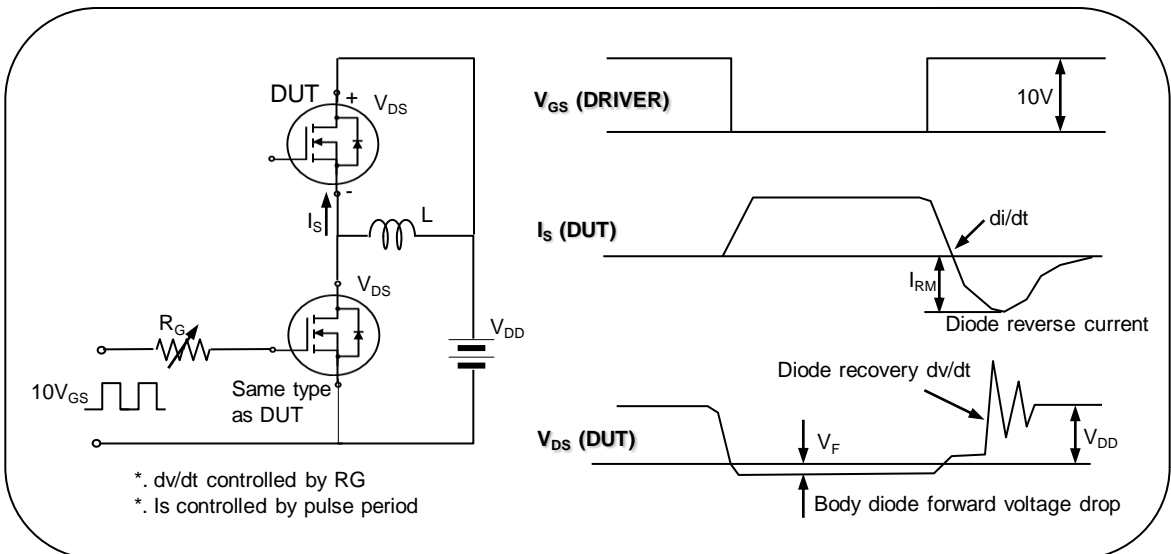

## TO-220 package dimension

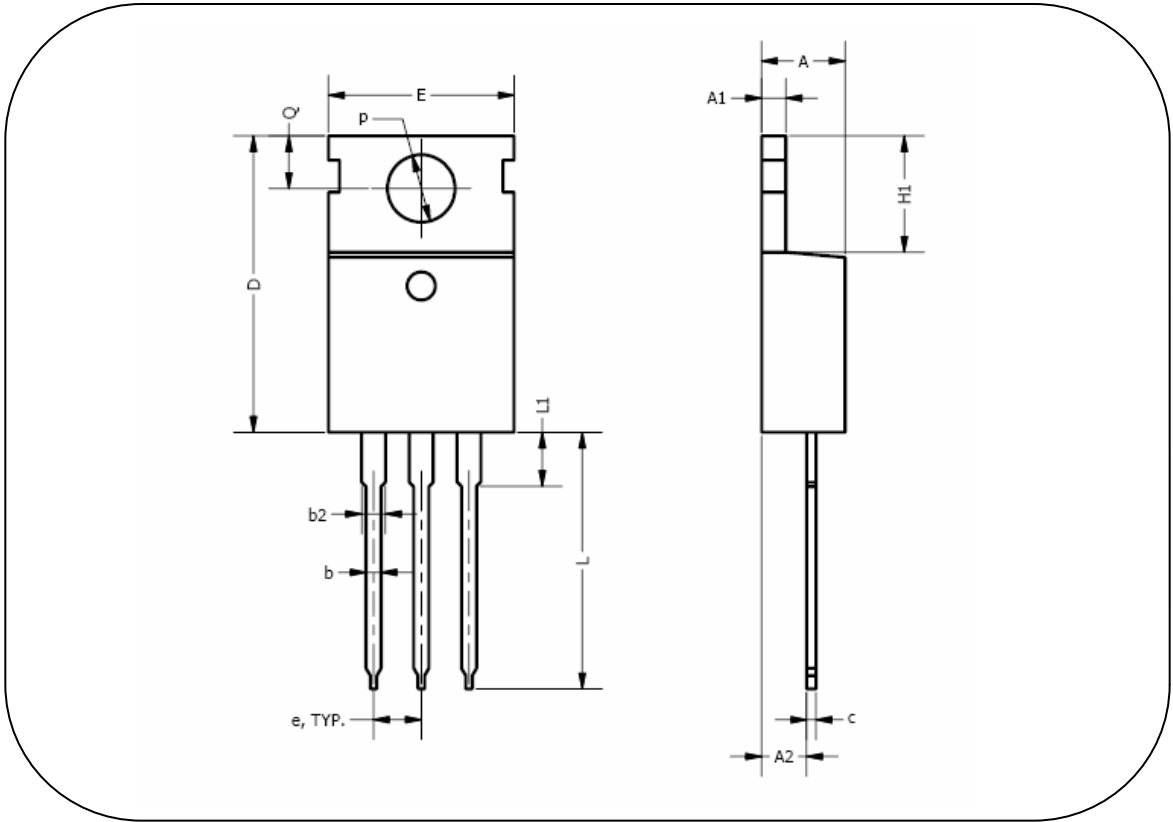

DIM	INCHES			MILLIMETERS		
	MIN	TYP	MAX	MIN	TYP	MAX
A	0.140	0.165	0.190	3.560	4.195	4.830
A1	0.020	0.038	0.055	0.510	0.955	1.400
A2	0.080	0.098	0.115	2.030	2.475	2.920
b	0.015	0.028	0.040	0.380	0.700	1.020
b2	0.045	0.058	0.070	1.140	1.460	1.780
c	0.014	0.019	0.024	0.360	0.485	0.610
D	0.560	0.605	0.650	14.220	15.365	16.510
e	0.096	0.100	0.104	2.440	2.540	2.640
E	0.380	0.400	0.420	9.650	10.160	10.670
H1	0.230	0.250	0.270	5.840	6.350	6.860
L	0.500	0.540	0.580	12.700	13.715	14.730
L1	-	-	0.250	-	-	6.350
⌀P	0.139	0.150	0.161	3.530	3.810	4.090
Q	0.100	0.118	0.135	2.540	2.985	3.430