

ANALOG DEVICES

1.2 MHz DC-DC Step-Up Switching Converter

ADP1610

FEATURES

Fully integrated 1.2 A, 0.2 Ω , power switch
 Pin-selectable 700 kHz or 1.2 MHz PWM frequency
 92% efficiency
 Adjustable output voltage up to 12 V
 3% output regulation accuracy
 Adjustable soft start
 Input undervoltage lockout
 MSOP 8-lead package

APPLICATIONS

TFT LC bias supplies
 Portable applications
 Industrial/instrumentation equipment

GENERAL DESCRIPTION

The ADP1610 is a dc-to-dc step-up switching converter with an integrated 1.2 A, 0.2 Ω power switch capable of providing an output voltage as high as 12 V. With a package height of less than 1.1 mm, the ADP1610 is optimal for space-constrained applications such as portable devices or thin film transistor (TFT) liquid crystal displays (LCDs).

The ADP1610 operates in pulse-width modulation (PWM) current mode with up to 92% efficiency. Adjustable soft start prevents inrush currents at startup. The pin-selectable switching frequency and PWM current-mode architecture allow excellent transient response, easy noise filtering, and the use of small, cost-saving external inductors and capacitors.

The ADP1610 is offered in the Pb-free 8-lead MSOP and operates over the temperature range of -40°C to $+85^{\circ}\text{C}$.

FUNCTIONAL BLOCK DIAGRAM

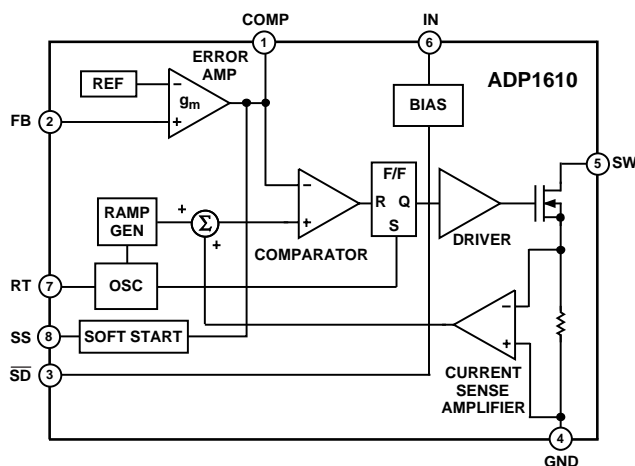

Figure 1.

Rev. 0

Information furnished by Analog Devices is believed to be accurate and reliable. However, no responsibility is assumed by Analog Devices for its use, nor for any infringements of patents or other rights of third parties that may result from its use. Specifications subject to change without notice. No license is granted by implication or otherwise under any patent or patent rights of Analog Devices. Trademarks and registered trademarks are the property of their respective owners.

One Technology Way, P.O. Box 9106, Norwood, MA 02062-9106, U.S.A.
 Tel: 781.329.4700 www.analog.com
 Fax: 781.326.8703 © 2004 Analog Devices, Inc. All rights reserved.

ADP1610

TABLE OF CONTENTS

Specifications.....	3	Choosing the Input and Output Capacitors	11
Absolute Maximum Ratings.....	4	Diode Selection.....	12
ESD Caution.....	4	Loop Compensation	12
Pin Configuration and Function Descriptions.....	5	Soft Start Capacitor	13
Typical Performance Characteristics	6	Application Circuits	13
Theory of Operation	10	DC-DC Step-Up Switching Converter with True Shutdown	14
Current-Mode PWM Operation	10	TFT LCD Bias Supply	14
Frequency Selection	10	Sepic Power Supply	14
Soft Start	10	Layout Procedure	15
On/Off Control.....	10	Outline Dimensions	16
Setting the Output Voltage	10	Ordering Guide	16

REVISION HISTORY

10/04—Revision 0: Initial Version

SPECIFICATIONS

$V_{IN} = 3.3\text{ V}$, $T_A = -40^\circ\text{C}$ to $+85^\circ\text{C}$, unless otherwise noted.

All limits at temperature extremes are guaranteed by correlation and characterization using standard statistical quality control (SQC), unless otherwise noted.

Table 1.

Parameter	Symbol	Conditions	Min	Typ	Max	Unit
SUPPLY						
Input Voltage	V_{IN}		2.5		5.5	V
Quiescent Current						
Nonswitching State	I_Q	$V_{FB} = 1.3\text{ V}$, $RT = V_{IN}$		390	600	μA
Shutdown	I_{QSD}	$V_{SD} = 0\text{ V}$		0.01	10	μA
Switching State ¹	I_{QSW}	$f_{SW} = 1.23\text{ MHz}$, no load		1	2	mA
OUTPUT						
Output Voltage	V_{OUT}		V_{IN}		12	V
Load Regulation		$I_{LOAD} = 10\text{ mA}$ to 150 mA , $V_{OUT} = 10\text{ V}$		0.05		mV/mA
Overall Regulation		Line, load, temperature		± 3		%
REFERENCE						
Feedback Voltage	V_{FB}		1.212	1.230	1.248	V
Line Regulation		$V_{IN} = 2.5\text{ V}$ to 5.5 V	-0.15		+0.15	%/V
ERROR AMPLIFIER						
Transconductance	g_m	$\Delta I = 1\ \mu\text{A}$		100		$\mu\text{A}/\text{V}$
Voltage Gain	A_V			60		dB
FB Input Bias Current		$V_{FB} = 1.23\text{ V}$		10		nA
SWITCH						
SW On Resistance	R_{ON}	$I_{SW} = 1.0\text{ A}$		200	400	$\text{m}\Omega$
SW Leakage Current		$V_{SW} = 12\text{ V}$		0.01	20	μA
Peak Current Limit ²	I_{CLSET}			2.0		A
OSCILLATOR						
Oscillator Frequency	f_{OSC}	$RT = \text{GND}$	0.49	0.7	0.885	MHz
		$RT = \text{IN}$	0.89	1.23	1.6	MHz
Maximum Duty Cycle	D_{MAX}	COMP = open, $V_{FB} = 1\text{ V}$, $RT = \text{GND}$	78	83	90	%
SHUTDOWN						
Shutdown Input Voltage Low	V_{IL}	Nonswitching state			0.6	V
Shutdown Input Voltage High	V_{IH}	Switching state	2.2			V
Shutdown Input Bias Current	I_{SD}	$V_{SD} = 3.3\text{ V}$		0.01	1	μA
SOFT START						
SS Charging Current		$V_{SS} = 0\text{ V}$		3		μA
UNDERVOLTAGE LOCKOUT³						
UVLO Threshold		V_{IN} rising	2.2	2.4	2.5	V
UVLO Hysteresis				220		mV

¹ This parameter specifies the average current while switching internally and with SW (Pin 5) floating.

² Guaranteed by design and not fully production tested.

³ Guaranteed by characterization.

ADP1610

ABSOLUTE MAXIMUM RATINGS

Table 2.

Parameter	Rating
IN, COMP, $\overline{\text{SD}}$, SS, RT, FB to GND	-0.3 V to +6 V
SW to GND	14 V
RMS SW Pin Current	1.2 A
Operating Ambient Temperature Range	-40°C to +85°C
Operating Junction Temperature Range	-40°C to +125°C
Storage Temperature Range	-65°C to +150°C
θ_{JA} , Two Layers	206°C/W
θ_{JA} , Four Layers	142°C/W
Lead Temperature Range (Soldering, 60 s)	300°C

Stresses above those listed under Absolute Maximum Ratings may cause permanent damage to the device. This is a stress rating only and functional operation of the device at these or any other conditions above those indicated in the operational section of this specification is not implied. Exposure to absolute maximum rating conditions for extended periods may affect device reliability. Absolute maximum ratings apply individually only, not in combination. Unless otherwise specified, all other voltages are referenced to GND.

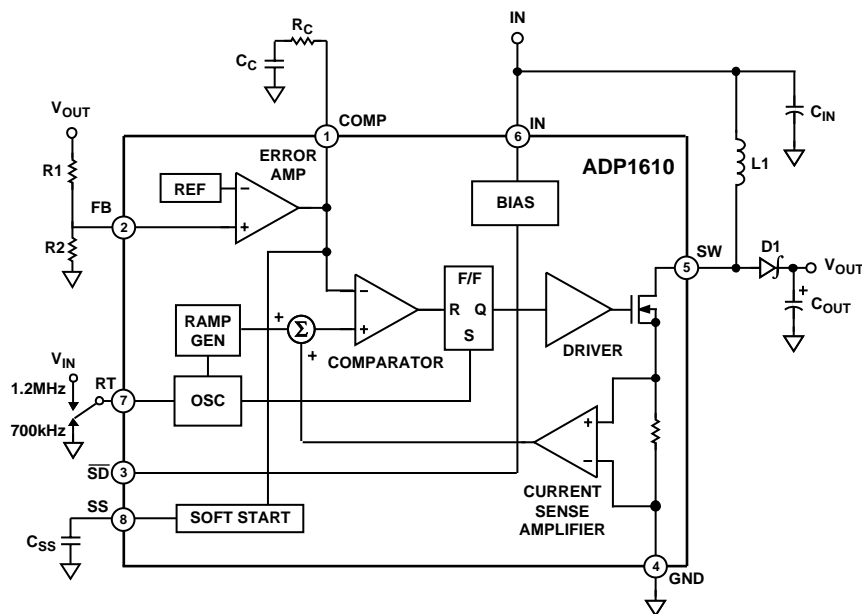

Figure 2. Block Diagram and Typical Application Circuit

ESD CAUTION

ESD (electrostatic discharge) sensitive device. Electrostatic charges as high as 4000 V readily accumulate on the human body and test equipment and can discharge without detection. Although this product features proprietary ESD protection circuitry, permanent damage may occur on devices subjected to high energy electrostatic discharges. Therefore, proper ESD precautions are recommended to avoid performance degradation or loss of functionality.



PIN CONFIGURATION AND FUNCTION DESCRIPTIONS

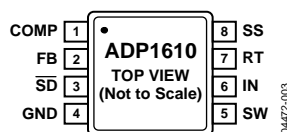

Figure 3. Pin Configuration

Table 3. Pin Function Descriptions

Pin No.	Mnemonic	Description
1	COMP	Compensation Input. Connect a series resistor-capacitor network from COMP to GND to compensate the regulator.
2	FB	Output Voltage Feedback Input. Connect a resistive voltage divider from the output voltage to FB to set the regulator output voltage.
3	\overline{SD}	Shutdown Input. Drive \overline{SD} low to shut down the regulator; drive \overline{SD} high to turn it on.
4	GND	Ground.
5	SW	Switching Output. Connect the power inductor from the input voltage to SW and connect the external rectifier from SW to the output voltage to complete the step-up converter.
6	IN	Main Power Supply Input. IN powers the ADP1610 internal circuitry. Connect IN to the input source voltage. Bypass IN to GND with a 10 μ F or greater capacitor as close to the ADP1610 as possible.
7	RT	Frequency Setting Input. RT controls the switching frequency. Connect RT to GND to program the oscillator to 700 kHz, or connect RT to IN to program it to 1.2 MHz.
8	SS	Soft Start Timing Capacitor Input. A capacitor from SS to GND brings up the output slowly at power-up.

ADP1610

TYPICAL PERFORMANCE CHARACTERISTICS

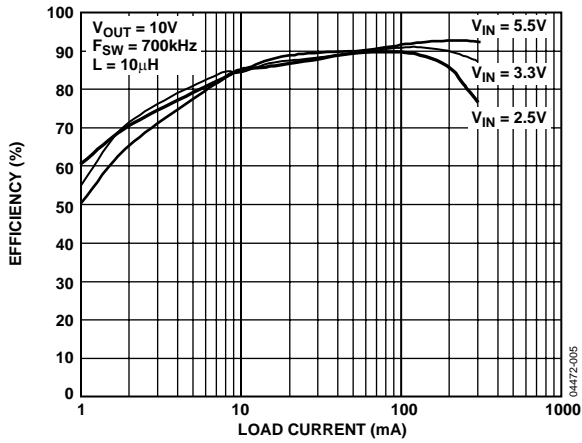

Figure 4. Output Efficiency vs. Load Current

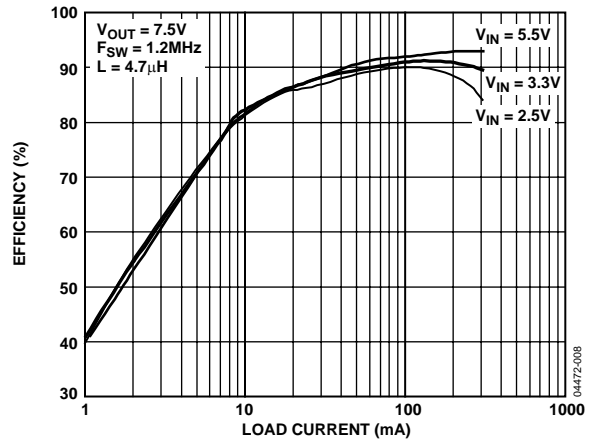

Figure 7. Output Efficiency vs. Load Current

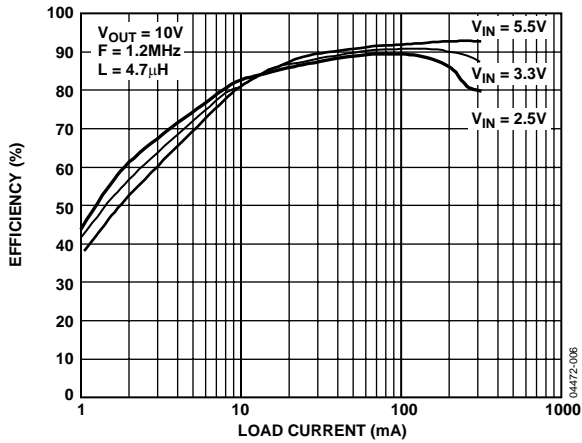

Figure 5. Output Efficiency vs. Load Current

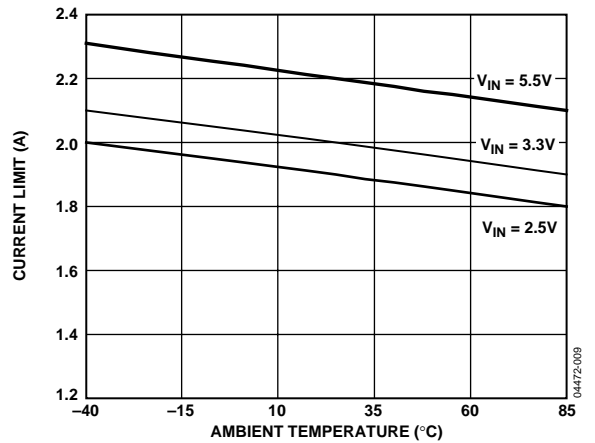

Figure 8. Current Limit vs. Ambient Temperature, $V_{OUT} = 10V$

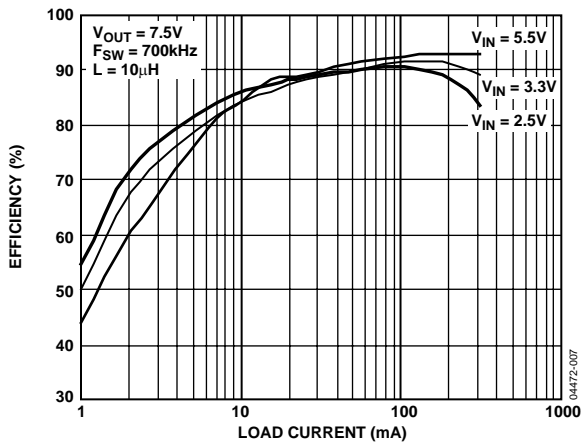

Figure 6. Output Efficiency vs. Load Current

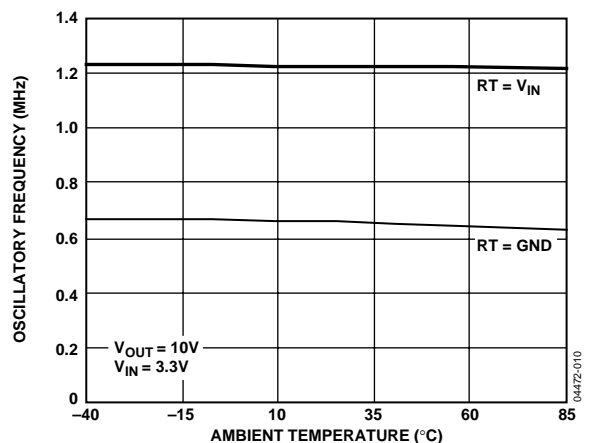

Figure 9. Oscillatory Frequency vs. Ambient Temperature

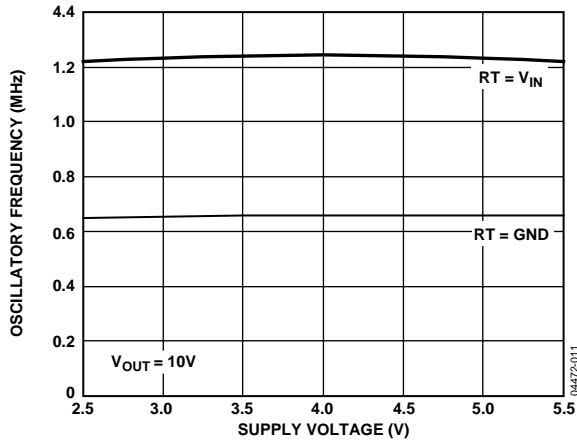

Figure 10. Oscillatory Frequency vs. Supply Voltage

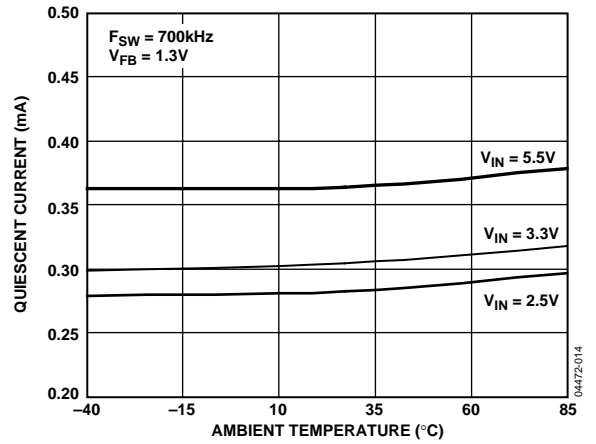

Figure 13. Quiescent Current vs. Ambient Temperature

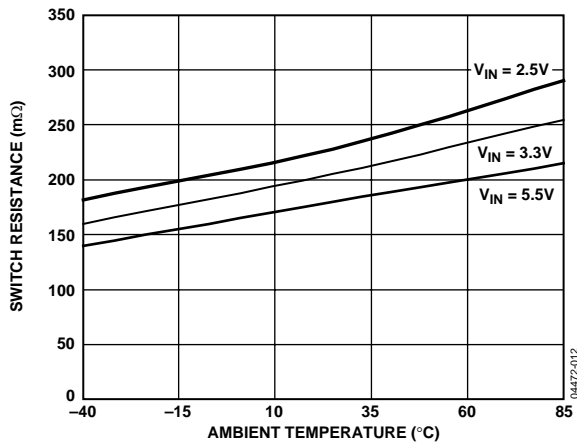

Figure 11. Switch Resistance vs. Ambient Temperature

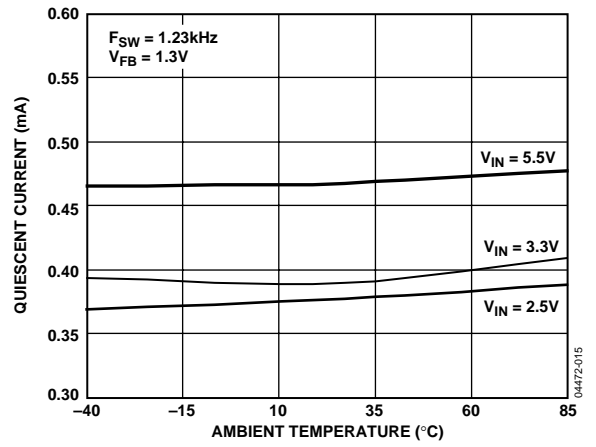

Figure 14. Quiescent Current vs. Ambient Temperature

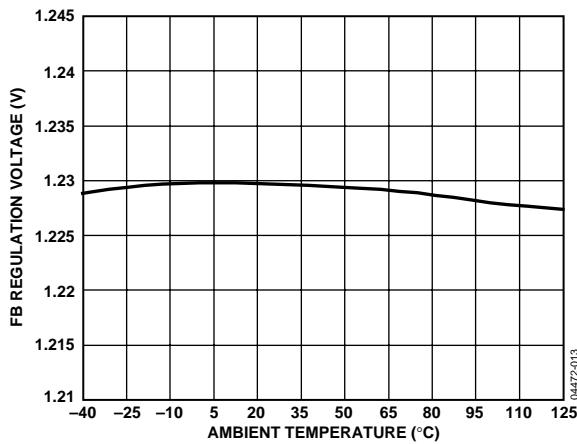

Figure 12. FB Regulation Voltage vs. Ambient Temperature

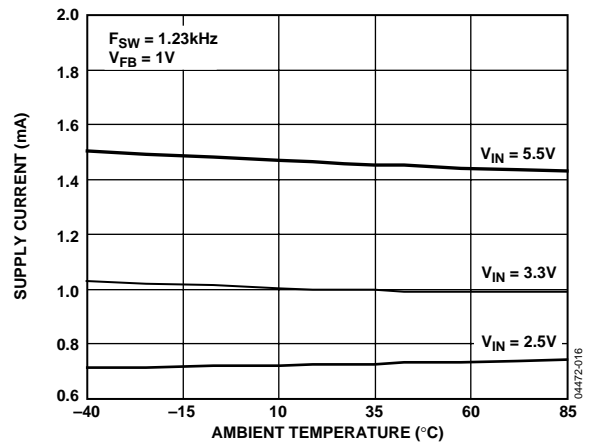

Figure 15. Supply Current vs. Ambient Temperature

ADP1610

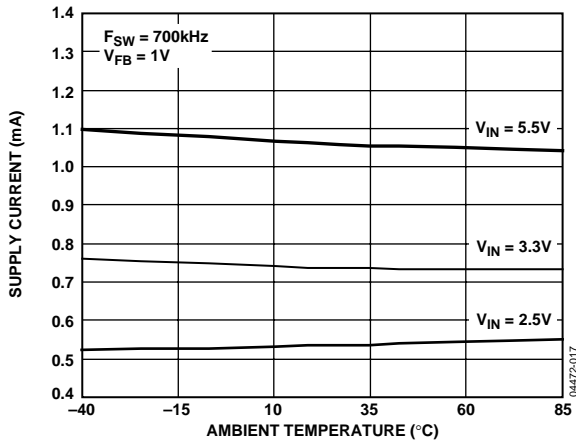

Figure 16. Supply Current vs. Ambient Temperature

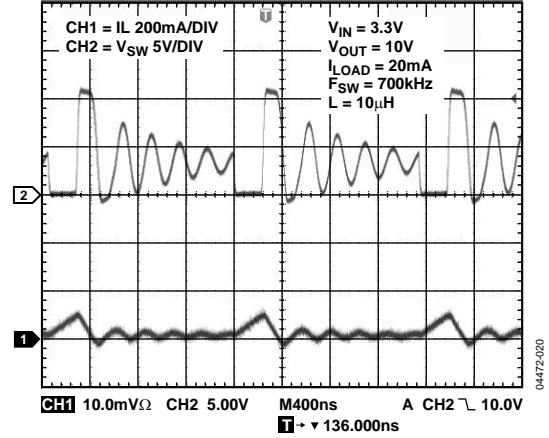

Figure 19. Switching Waveform in Discontinuous Conduction

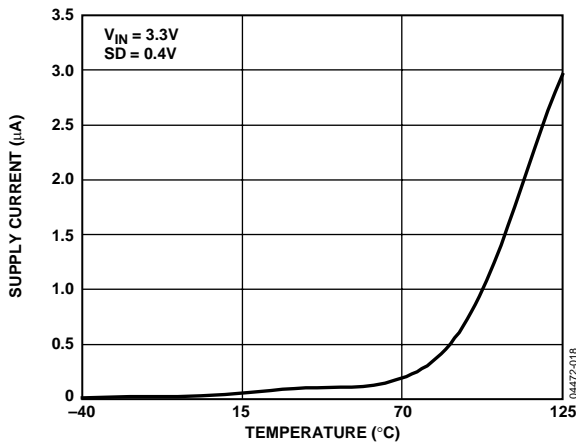

Figure 17. Supply Current in Shutdown vs. Ambient Temperature

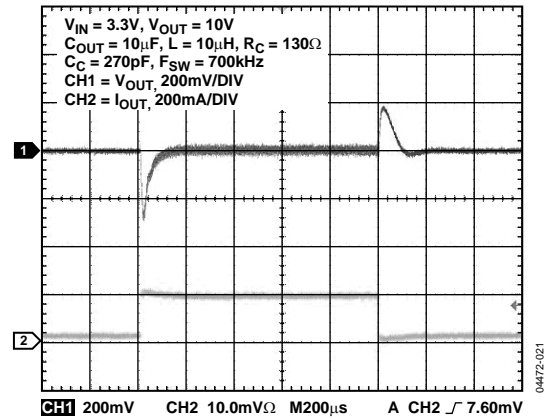

Figure 20. Load Transient Response, 700 kHz, $V_{OUT} = 10V$

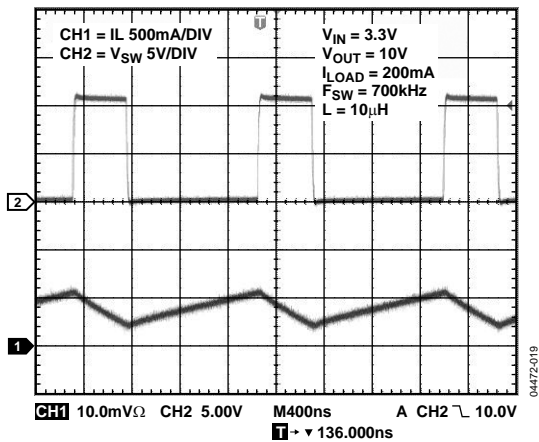

Figure 18. Switching Waveform in Continuous Conduction

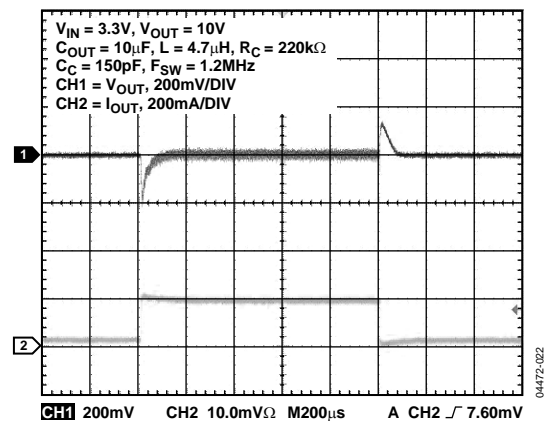

Figure 21. Load Transient Response, 1.2 MHz, $V_{OUT} = 10V$

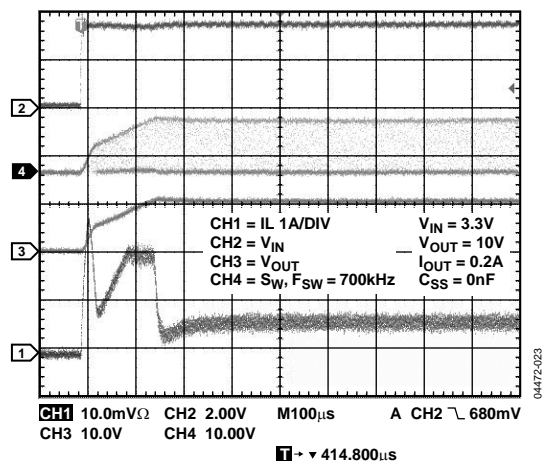

Figure 22. Start-Up Response from V_{IN} , $SS = 0 nF$

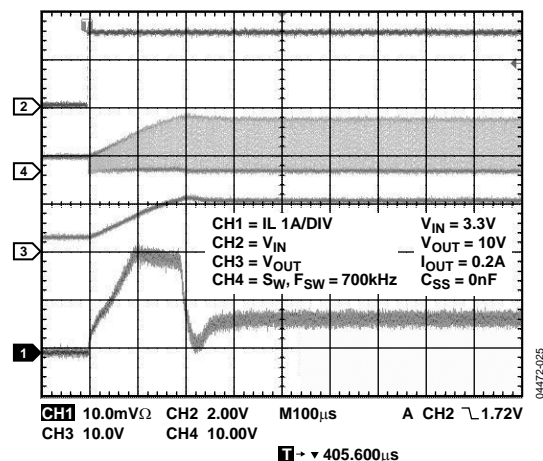

Figure 24. Start-Up Response from Shutdown, $SS = 0 nF$

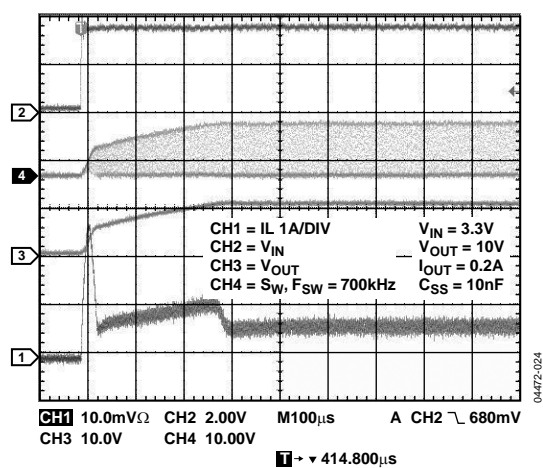

Figure 23. Start-Up Response from V_{IN} , $SS = 10 nF$

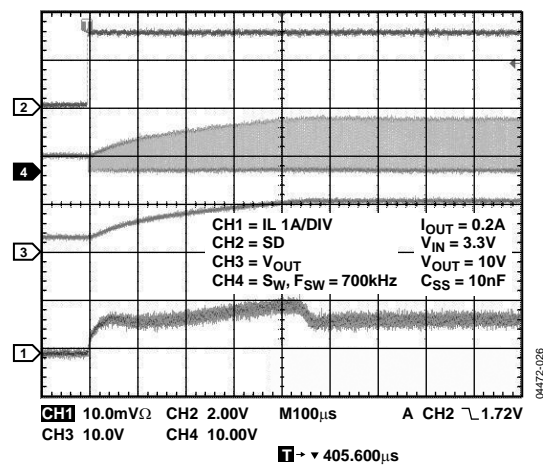

Figure 25. Start-Up Response from Shutdown, $SS = 10 nF$

ADP1610

THEORY OF OPERATION

The ADP1610 current-mode step-up switching converter converts a 2.5 V to 5.5 V input voltage up to an output voltage as high as 12 V. The 1.2 A internal switch allows a high output current, and the high 1.2 MHz switching frequency allows tiny external components. The switch current is monitored on a pulse-by-pulse basis to limit it to 2 A.

CURRENT-MODE PWM OPERATION

The ADP1610 uses current-mode architecture to regulate the output voltage. The output voltage is monitored at FB through a resistive voltage divider. The voltage at FB is compared to the internal 1.23 V reference by the internal transconductance error amplifier to create an error current at COMP. A series resistor-capacitor at COMP converts the error current to a voltage. The switch current is internally measured and added to the stabilizing ramp, and the resulting sum is compared to the error voltage at COMP to control the PWM modulator. This current-mode regulation system allows fast transient response, while maintaining a stable output voltage. By selecting the proper resistor-capacitor network from COMP to GND, the regulator response is optimized for a wide range of input voltages, output voltages, and load conditions.

FREQUENCY SELECTION

The ADP1610's frequency is user-selectable to operate at either 700 kHz to optimize the regulator for high efficiency or to 1.2 MHz for small external components. Connect RT to IN for 1.2 MHz operation, or connect RT to GND for 700 kHz operation. To achieve the maximum duty cycle, which might be required for converting a low input voltage to a high output voltage, use the lower 700 kHz switching frequency.

SOFT START

To prevent input inrush current at startup, connect a capacitor from SS to GND to set the soft start period. When the ADP1610 is in shutdown (\overline{SD} is at GND) or the input voltage is below the 2.4 V undervoltage lockout voltage, SS is internally shorted to GND to discharge the soft start capacitor. Once the ADP1610 is turned on, SS sources 3 μ A to the soft start capacitor at startup. As the soft start capacitor charges, it limits the voltage at COMP. Because of the current-mode regulator, the voltage at COMP is proportional to the switch peak current, and, therefore, the input current. By slowly charging the soft start capacitor, the input current ramps slowly to prevent it from overshooting excessively at startup.

ON/OFF CONTROL

The \overline{SD} input turns the ADP1610 regulator on or off. Drive \overline{SD} low to turn off the regulator and reduce the input current to 10 nA. Drive \overline{SD} high to turn on the regulator.

When the dc-dc step-up switching converter is turned off, there is a dc path from the input to the output through the inductor and output rectifier. This causes the output voltage to remain slightly below the input voltage by the forward voltage of the rectifier, preventing the output voltage from dropping to zero when the regulator is shut down. Figure 28 shows the application circuit to disconnect the output voltage from the input voltage at shutdown.

SETTING THE OUTPUT VOLTAGE

The ADP1610 features an adjustable output voltage range of V_{IN} to 12 V. The output voltage is set by the resistive voltage divider (R1 and R2 in Figure 2) from the output voltage (V_{OUT}) to the 1.230 V feedback input at FB. Use the following formula to determine the output voltage:

$$V_{OUT} = 1.23 \times (1 + R1/R2) \quad (1)$$

Use an R2 resistance of 10 k Ω or less to prevent output voltage errors due to the 10 nA FB input bias current. Choose R1 based on the following formula:

$$R1 = R2 \times \left(\frac{V_{OUT} - 1.23}{1.23} \right) \quad (2)$$

INDUCTOR SELECTION

The inductor is an essential part of the step-up switching converter. It stores energy during the on-time, and transfers that energy to the output through the output rectifier during the off-time. Use inductance in the range of 1 μ H to 22 μ H. In general, lower inductance values have higher saturation current and lower series resistance for a given physical size. However, lower inductance results in higher peak current that can lead to reduced efficiency and greater input and/or output ripple and noise. Peak-to-peak inductor ripple current at close to 30% of the maximum dc input current typically yields an optimal compromise.

For determining the inductor ripple current, the input (V_{IN}) and output (V_{OUT}) voltages determine the switch duty cycle (D) by the following equation:

$$D = \frac{V_{OUT} - V_{IN}}{V_{OUT}} \quad (3)$$

Table 4. Inductor Manufacturers

Vendor	Part	L (μH)	Max DC Current	Max DCR (mΩ)	Height (mm)
Sumida 847-956-0666 www.sumida.com	CMD4D11-2R2MC	2.2	0.95	116	1.2
	CMD4D11-4R7MC	4.7	0.75	216	1.2
	CDRH4D28-100	10	1.00	128	3.0
	CDRH5D18-220	22	0.80	290	2.0
	CR43-4R7	4.7	1.15	109	3.5
	CR43-100	10	1.04	182	3.5
Coilcraft 847-639-6400 www.coilcraft.com	DS1608-472	4.7	1.40	60	2.9
	DS1608-103	10	1.00	75	2.9
Toko 847-297-0070 www.tokoam.com	D52LC-4R7M	4.7	1.14	87	2.0
	D52LC-100M	10	0.76	150	2.0

Using the duty cycle and switching frequency, f_{SW} , determine the on-time by the following equation:

$$t_{ON} = \frac{D}{f_{SW}} \quad (4)$$

The inductor ripple current (ΔI_L) in steady state is

$$\Delta I_L = \frac{V_{IN} \times t_{ON}}{L} \quad (5)$$

Solving for the inductance value, L,

$$L = \frac{V_{IN} \times t_{ON}}{\Delta I_L} \quad (6)$$

Make sure that the peak inductor current (the maximum input current plus half the inductor ripple current) is below the rated saturation current of the inductor. Likewise, make sure that the maximum rated rms current of the inductor is greater than the maximum dc input current to the regulator.

For duty cycles greater than 50%, which occur with input voltages greater than one-half the output voltage, slope compensation is required to maintain stability of the current-mode regulator. For stable current-mode operation, ensure that the selected inductance is equal to or greater than L_{MIN} :

$$L > L_{MIN} = \frac{V_{OUT} - V_{IN}}{1.8 A \times f_{SW}} \quad (7)$$

CHOOSING THE INPUT AND OUTPUT CAPACITORS

The ADP1610 requires input and output bypass capacitors to supply transient currents while maintaining constant input and output voltage. Use a low ESR (equivalent series resistance), 10 μF or greater input capacitor to prevent noise at the ADP1610 input. Place the capacitor between IN and GND as close to the ADP1610 as possible. Ceramic capacitors are preferred because of their low ESR characteristics. Alternatively, use a high value, medium ESR capacitor in parallel with a 0.1 μF low ESR capacitor as close to the ADP1610 as possible.

The output capacitor maintains the output voltage and supplies current to the load while the ADP1610 switch is on. The value and characteristics of the output capacitor greatly affect the output voltage ripple and stability of the regulator. Use a low ESR output capacitor; ceramic dielectric capacitors are preferred.

For very low ESR capacitors such as ceramic capacitors, the ripple current due to the capacitance is calculated as follows. Because the capacitor discharges during the on-time, t_{ON} , the charge removed from the capacitor, Q_C , is the load current multiplied by the on-time. Therefore, the output voltage ripple (ΔV_{OUT}) is

$$\Delta V_{OUT} = \frac{Q_C}{C_{OUT}} = \frac{I_L \times t_{ON}}{C_{OUT}} \quad (8)$$

where:

C_{OUT} is the output capacitance,
 I_L is the average inductor current,

$$t_{ON} = \frac{D}{f_{SW}} \quad (9)$$

and

$$D = \frac{V_{OUT} - V_{IN}}{V_{OUT}} \quad (10)$$

Choose the output capacitor based on the following equation:

$$C_{OUT} \geq \frac{I_L \times (V_{OUT} - V_{IN})}{f_{SW} \times V_{OUT} \times \Delta V_{OUT}} \quad (11)$$

Table 5. Capacitor Manufacturers

Vendor	Phone No.	Web Address
AVX	408-573-4150	www.avxcorp.com
Murata	714-852-2001	www.murata.com
Sanyo	408-749-9714	www.sanyovideo.com
Taiyo-Yuden	408-573-4150	www.t-yuden.com

ADP1610

DIODE SELECTION

The output rectifier conducts the inductor current to the output capacitor and load while the switch is off. For high efficiency, minimize the forward voltage drop of the diode. For this reason, Schottky rectifiers are recommended. However, for high voltage, high temperature applications, where the Schottky rectifier reverse leakage current becomes significant and can degrade efficiency, use an ultrafast junction diode.

Make sure that the diode is rated to handle the average output load current. Many diode manufacturers derate the current capability of the diode as a function of the duty cycle. Verify that the output diode is rated to handle the average output load current with the minimum duty cycle. The minimum duty cycle of the ADP1610 is

$$D_{MIN} = \frac{V_{OUT} - V_{IN-MAX}}{V_{OUT}} \quad (12)$$

where V_{IN-MAX} is the maximum input voltage.

Table 6. Schottky Diode Manufacturers

Vendor	Phone No.	Web Address
Motorola	602-244-3576	www.mot.com
Diodes, Inc.	805-446-4800	www.diodes.com
Sanyo	310-322-3331	www.irf.com

LOOP COMPENSATION

The ADP1610 uses external components to compensate the regulator loop, allowing optimization of the loop dynamics for a given application.

The step-up converter produces an undesirable right-half plane zero in the regulation feedback loop. This requires compensating the regulator such that the crossover frequency occurs well below the frequency of the right-half plane zero. The right-half plane zero is determined by the following equation:

$$F_Z(RHP) = \left(\frac{V_{IN}}{V_{OUT}} \right)^2 \times \frac{R_{LOAD}}{2\pi \times L} \quad (13)$$

where:

$F_Z(RHP)$ is the right-half plane zero.

R_{LOAD} is the equivalent load resistance or the output voltage divided by the load current.

To stabilize the regulator, make sure that the regulator crossover frequency is less than or equal to one-fifth of the right-half plane zero and less than or equal to one-fifteenth of the switching frequency.

The regulator loop gain is

$$A_{VL} = \frac{V_{FB}}{V_{OUT}} \times \frac{V_{IN}}{V_{OUT}} \times G_{MEA} \times |Z_{COMP}| \times G_{CS} \times |Z_{OUT}| \quad (14)$$

where:

A_{VL} is the loop gain.

V_{FB} is the feedback regulation voltage, 1.230 V.

V_{OUT} is the regulated output voltage.

V_{IN} is the input voltage.

G_{MEA} is the error amplifier transconductance gain.

Z_{COMP} is the impedance of the series RC network from COMP to GND.

G_{CS} is the current sense transconductance gain (the inductor current divided by the voltage at COMP), which is internally set by the ADP1610.

Z_{OUT} is the impedance of the load and output capacitor.

To determine the crossover frequency, it is important to note that, at that frequency, the compensation impedance (Z_{COMP}) is dominated by the resistor, and the output impedance (Z_{OUT}) is dominated by the impedance of the output capacitor. So, when solving for the crossover frequency, the equation (by definition of the crossover frequency) is simplified to

$$|A_{VL}| = \frac{V_{FB}}{V_{OUT}} \times \frac{V_{IN}}{V_{OUT}} \times G_{MEA} \times R_{COMP} \times G_{CS} \times \frac{1}{2\pi \times f_C \times C_{OUT}} = 1 \quad (15)$$

where:

f_C is the crossover frequency.

R_{COMP} is the compensation resistor.

Solving for R_{COMP} ,

$$R_{COMP} = \frac{2\pi \times f_C \times C_{OUT} \times V_{OUT} \times V_{OUT}}{V_{FB} \times V_{IN} \times G_{MEA} \times G_{CS}} \quad (16)$$

For $V_{FB} = 1.23$, $G_{MEA} = 100 \mu S$, and $G_{CS} = 2 S$,

$$R_{COMP} = \frac{2.55 \times 10^4 \times f_C \times C_{OUT} \times V_{OUT} \times V_{OUT}}{V_{IN}} \quad (17)$$

Once the compensation resistor is known, set the zero formed by the compensation capacitor and resistor to one-fourth of the crossover frequency, or

$$C_{COMP} = \frac{2}{\pi \times f_C \times R_{COMP}} \quad (18)$$

where C_{COMP} is the compensation capacitor.

Table 7. Recommended External Components for Popular Input/Output Voltage Conditions

V _{IN} (V)	V _{OUT} (V)	f _{sw} (MHz)	L (μH)	C _{OUT} (μF)	C _{IN} (μF)	R ₁ (kΩ)	R ₂ (kΩ)	R _{comp} (kΩ)	C _{comp} (pF)	I _{OUT_MAX} (mA)
3.3	5	0.700	4.7	10	10	30.9	10	50	520	600
	5	1.23	2.7	10	10	30.9	10	90.9	150	600
	9	0.700	10	10	10	63.4	10	71.5	820	350
	9	1.23	4.7	10	10	63.4	10	150	180	350
	12	0.700	10	10	10	88.7	10	130	420	250
	12	1.23	4.7	10	10	88.7	10	280	100	250
5	9	0.700	10	10	10	63.4	10	84.5	390	450
	9	1.23	4.7	10	10	63.4	10	178	100	450
	12	0.700	10	10	10	88.7	10	140	220	350
	12	1.23	4.7	10	10	88.7	10	300	100	350

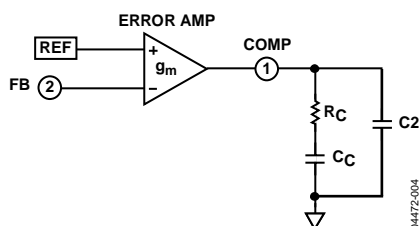

Figure 26. Compensation Components

The capacitor, C₂, is chosen to cancel the zero introduced by output capacitance ESR.

Solving for C₂,

$$C_2 = \frac{ESR \times C_{OUT}}{R_{COMP}} \quad (19)$$

For low ESR output capacitance such as with a ceramic capacitor, C₂ is optional. For optimal transient performance, the R_{COMP} and C_{COMP} might need to be adjusted by observing the load transient response of the ADP1610. For most applications, the compensation resistor should be in the range of 30 kΩ to 400 kΩ, and the compensation capacitor should be in the range of 100 pF to 1.2 nF. Table 7 shows external component values for several applications.

SOFT START CAPACITOR

The voltage at SS ramps up slowly by charging the soft start capacitor (C_{SS}) with an internal 3 μA current source. Table 8 listed the values for the soft start period, based on maximum output current and maximum switching frequency.

The soft start capacitor limits the rate of voltage rise on the COMP pin, which in turn limits the peak switch current at startup. Table 8 shows a typical soft start period, t_{SS}, at maximum output current, I_{OUT_MAX}, for several conditions.

A 20 nF soft start capacitor results in negligible input current overshoot at startup, and so is suitable for most applications. However, if an unusually large output capacitor is used, a longer soft start period is required to prevent input inrush current.

Table 8. Typical Soft Start Period

V _{IN} (V)	V _{OUT} (V)	C _{OUT} (μF)	C _{SS} (nF)	t _{SS} (ms)
3.3	5	10	20	0.3
	5	10	100	2
	9	10	20	2.5
	9	10	100	8.2
	12	10	20	3.5
	12	10	100	15
5	9	10	20	0.4
	9	10	100	1.5
	12	10	20	0.62
	12	10	100	2

Conversely, if fast startup is a requirement, the soft start capacitor can be reduced or even removed, allowing the ADP1610 to start quickly, but allowing greater peak switch current (see Figure 22 to Figure 25).

APPLICATION CIRCUITS

The circuit in Figure 27 shows the ADP1610 in a step-up configuration. The ADP1610 is used here to generate a 10 V regulator with the following specifications: V_{IN} = 2.5 V to 5.5 V, V_{OUT} = 10 V, and I_{OUT} ≤ 400 mA.

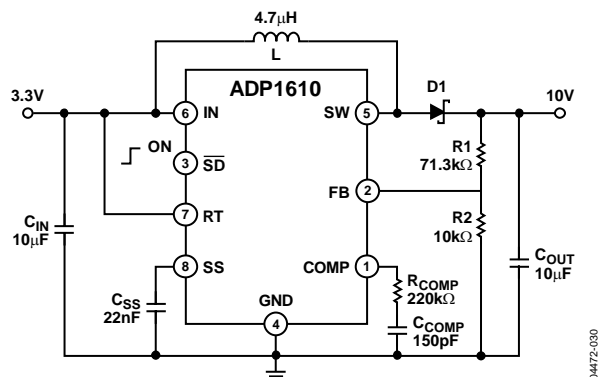

Figure 27. 3.3V to 10V Step-Up Regulator

The output can be set to the desired voltage using Equation 2. Use Equation 16 and 17 to change the compensation network.

ADP1610

DC-DC STEP-UP SWITCHING CONVERTER WITH TRUE SHUTDOWN

Some battery-powered applications require very low standby current. The ADP1610 typically consumes 10 nA from the input, which makes it suitable for these applications. However, the output is connected to the input through the inductor and the rectifying diode, allowing load current draw from the input while shut down. The circuit in Figure 28 enables the ADP1610 to achieve output load disconnect at shutdown. To shut down the ADP1610 and disconnect the output from the input, drive the \overline{SD} pin below 0.4 V.

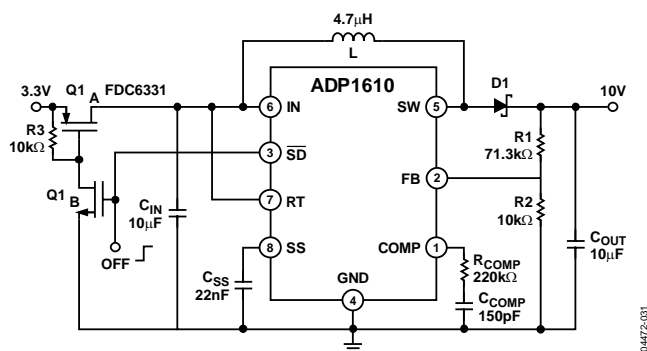

Figure 28. Step-Up Regulator with True Shutdown

TFT LCD BIAS SUPPLY

Figure 29 shows a power supply circuit for TFT LCD module applications. This circuit has +10 V, -5 V, and +22 V outputs. The +10 V is generated in the step-up configuration. The -5 V and +22 V are generated by the charge-pump circuit. During the step-up operation, the SW node switches between 10 V and ground (neglecting forward drop of the diode and on resistance of the switch). When the SW node is high, C5 charges up to 10 V. C5 holds its charge and forward-biases D8 to charge C6 to -10 V. The Zener diode, D9, clamps and regulates the output to -5 V.

The VGH output is generated in a similar manner by the charge-pump capacitors, C1, C2, and C4. The output voltage is tripled and regulated down to 22 V by the Zener diode, D5.

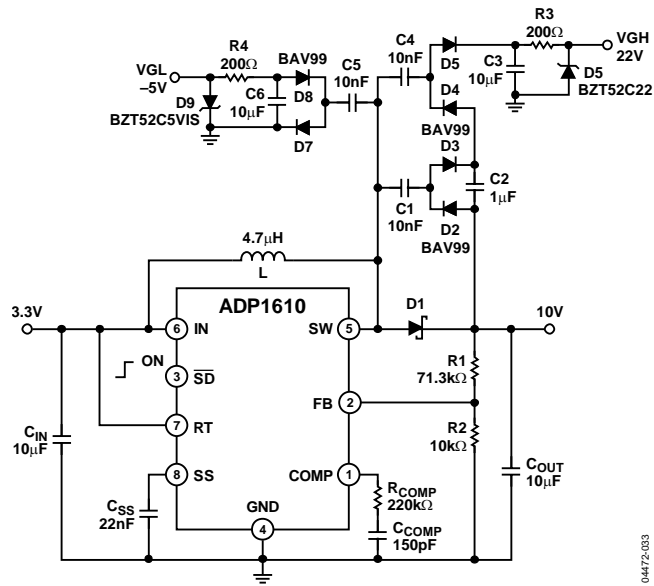

Figure 29. TFT LCD Bias Supply

SEPIC POWER SUPPLY

The circuit in Figure 30 shows the ADP1610 in a single-ended primary inductance converter (SEPIC) topology. This topology is useful for an unregulated input voltage, such as a battery-powered application in which the input voltage can vary between 2.7 V to 5 V, and the regulated output voltage falls within the input voltage range.

The input and the output are dc-isolated by a coupling capacitor, C1. In steady state, the average voltage of C1 is the input voltage. When the ADP1610 switch turns on and the diode turns off, the input voltage provides energy to L1, and C1 provides energy to L2. When the ADP1610 switch turns off and the diode turns on, the energy in L1 and L2 is released to charge the output capacitor, C_{OUT}, and the coupling capacitor, C1, and to supply current to the load.

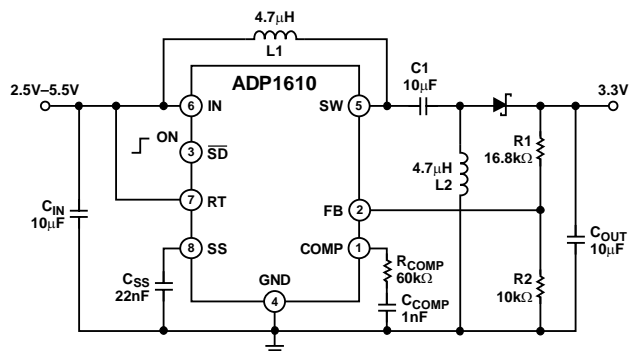

Figure 30. 3.3 V DC-DC Converter

LAYOUT PROCEDURE

To get high efficiency, good regulation, and stability, a well-designed printed circuit board layout is required. Where possible, use the sample application board layout as a model.

Follow these guidelines when designing printed circuit boards (see Figure 1):

- Keep the low ESR input capacitor, C_{IN} , close to IN and GND .
- Keep the high current path from C_{IN} through the inductor $L1$ to SW and $PGND$ as short as possible.
- Keep the high current path from C_{IN} through $L1$, the rectifier $D1$, and the output capacitor C_{OUT} as short as possible.
- Keep high current traces as short and as wide as possible.
- Place the feedback resistors as close to the FB pin as possible to prevent noise pickup.
- Place the compensation components as close as possible to $COMP$.
- Avoid routing high impedance traces near any node connected to SW or near the inductor to prevent radiated noise injection.

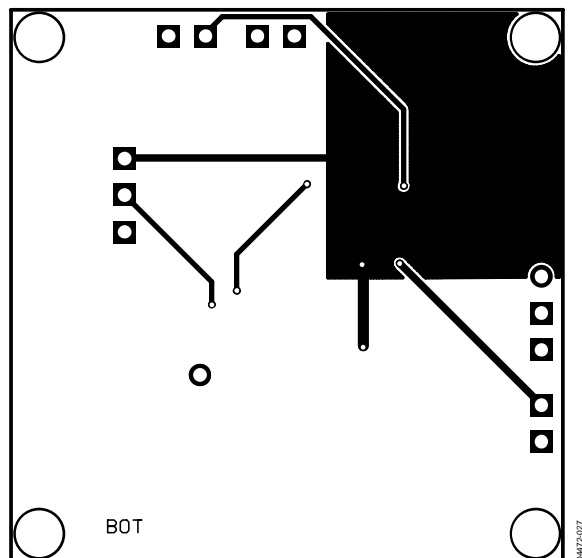

Figure 31. Sample Application Board (Bottom Layer)

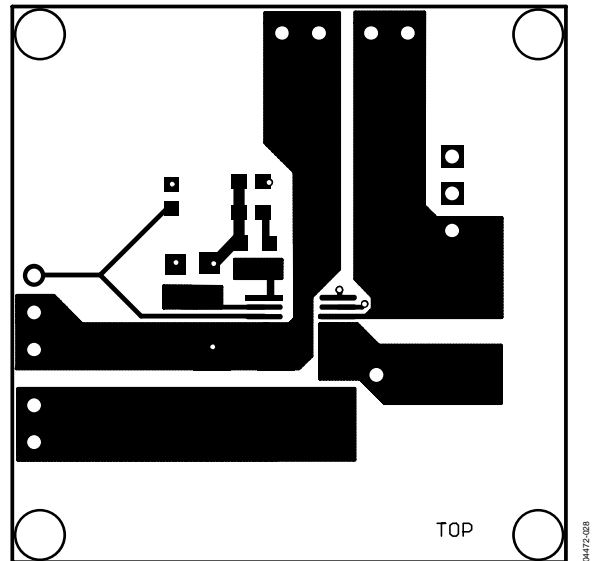

Figure 32. Sample Application Board (Top Layer)

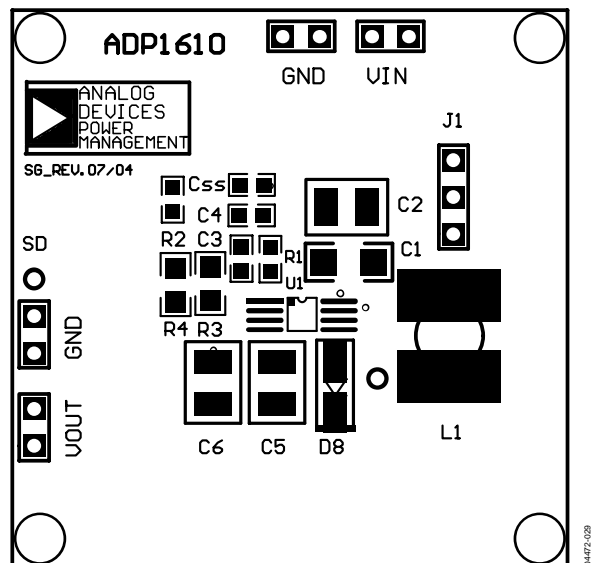
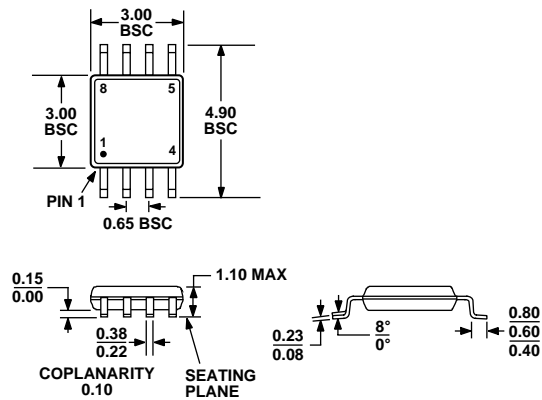

Figure 33. Sample Application Board (Silkscreen Layer)

OUTLINE DIMENSIONS



COMPLIANT TO JEDEC STANDARDS MO-187AA

Figure 34. 8-Lead Mini Small Outline Package [MSOP]
(RM-8)

Dimensions shown in millimeters

ORDERING GUIDE

Model	Temperature Range	Package Description	Package Option	Branding
ADP1610ARMZ-R7 ¹	-40°C to +85°C	8-Lead Mini Small Outline Package [MSOP]	RM-8	P03

¹ Z = Pb-free part.