

FEATURES

Fully operational down to 0 Hz/dc

On resistance: 1.8 Ω (typical)

Off leakage: 0.5 nA (maximum)

-3 dB bandwidth

13 GHz (typical) for RF2, RF3

10.8 GHz (typical) for RF1, RF4

RF performance characteristics

Insertion loss: 0.45 dB (typical) at 2.5 GHz

Isolation: 24 dB (typical) at 2.5 GHz

IIP3: 67 dBm (typical)

RF power: 32 dBm (maximum)

Actuation lifetime: 1 billion cycles (minimum)

Hermetically sealed switch contacts

On switching time: 30 μ s (typical)

ESD HBM rating

5 kV for RF1 to RF4 and RFC pins

2.5 kV for all other pins

Integrated driver removes the need for an external driver

Supply voltage: 3.1 V to 3.3 V

CMOS/LVTTL compatible

Parallel and independently controllable switches

Switch is in an open state with no power supply present

Requirement to avoid floating nodes on all RFx pins (see the

Applications Information section)

5 mm \times 4 mm \times 1.45 mm, 24-lead LFCSP

Operating temperature range: 0°C to 85°C

APPLICATIONS

Relay replacements

Automatic test equipment (ATE): RF, digital, and mixed signals

Load and probe boards: RF, digital, and mixed signals

RF test instrumentation

Reconfigurable filters and attenuators

High performance RF switching

GENERAL DESCRIPTION

The ADGM1004 is a wideband, single-pole, four-throw (SP4T) switch, fabricated using Analog Devices, Inc., microelectro-mechanical system (MEMS) switch technology. This technology enables a small form factor, wide radio frequency (RF) bandwidth, highly linear, low insertion loss switch that is operational down to 0 Hz/dc, making it an ideal solution for a wide range of RF and precision equipment switching needs.

An integrated control chip generates the high voltage necessary to electrostatically actuate the switch via a parallel interface. All four switches are independently controllable.

The device is packaged in a 24-lead, 5 mm \times 4 mm \times 1.45 mm lead frame chip-scale package (LFCSP).

FUNCTIONAL BLOCK DIAGRAM

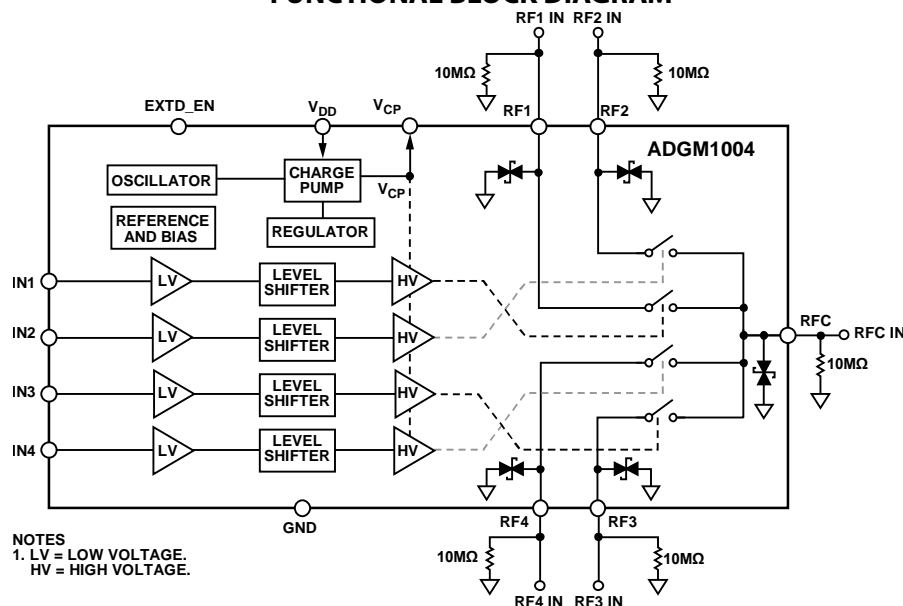

Figure 1.

Rev. C

[Document Feedback](#)

Information furnished by Analog Devices is believed to be accurate and reliable. However, no responsibility is assumed by Analog Devices for its use, nor for any infringements of patents or other rights of third parties that may result from its use. Specifications subject to change without notice. No license is granted by implication or otherwise under any patent or patent rights of Analog Devices. Trademarks and registered trademarks are the property of their respective owners.

One Technology Way, P.O. Box 9106, Norwood, MA 02062-9106, U.S.A.
Tel: 781.329.4700 ©2017–2019 Analog Devices, Inc. All rights reserved.
[Technical Support](#) www.analog.com

TABLE OF CONTENTS

Features	1	Low Power Mode.....	18
Applications.....	1	Typical Operating Circuit	18
General Description	1	Applications Information	19
Functional Block Diagram	1	Floating Node Avoidance.....	19
Revision History	2	Continuously on Lifetime	20
Specifications.....	3	Suggested Application Circuits.....	21
Absolute Maximum Ratings.....	5	Switchable RF Attenuator.....	21
Thermal Resistance	5	Reconfigurable RF Filter	21
ESD Caution.....	5	Handling Guidelines	22
Pin Configuration and Function Descriptions.....	6	Electrical Overstress (EOS) Precautions	22
Typical Performance Characteristics	7	DC Voltage Range	22
Test Circuits.....	12	Voltage Standoff Limit.....	22
Terminology	15	Mechanical Shock Precautions	22
Theory of Operation	17	Outline Dimensions.....	23
Digital Interface	17	Ordering Guide	23
Internal Oscillator	18		
Oscillator Feedthrough Mitigation	18		

REVISION HISTORY

3/2019—Rev. B to Rev. C

Change to Features Section and Figure 1	1
Changes to Specifications Section and Table 1.....	3
Deleted Endnote 1, Endnote 3, and Endnote 6 in Table 1; Renumbered Sequentially.....	4
Changes to Table 2.....	5
Changes to Table 4.....	6
Updated Typical Performance Characteristics Section Format.....	7
Changes to Figure 6 to Figure 8 Captions	7
Added Figure 9 to Figure 12; Renumbered Sequentially	8
Deleted Figure 15.....	9
Added Figure 19 and Figure 20.....	9
Added Figure 24 to Figure 26.....	10
Added Figure 27 to Figure 30.....	11
Changes to Figure 32 Caption.....	12
Added Figure 33.....	12
Deleted Figure 27 to Figure 29.....	12
Changes to Figure 35.....	13
Changes to Figure 37 Caption.....	13
Added Figure 39, Figure 40, and Figure 42.....	14
Changes to Terminology Section.....	15
Changes to Theory of Operation Section.....	17
Changed Internal Oscillator/EXTD_EN Section to Internal Oscillator Section.....	18

Changes to Internal Oscillator Section, Typical Operating Circuit Section	18
Replaced Figure 44	18
Added Oscillator Feedthrough Mitigation Section and Low Power Mode Section	18
Changes to Figure 50 and Figure 51.....	19
Added Voltage Standoff Limit Section	22

3/2018—Rev. A to Rev. B

Changes to Features Section	1
Changes to Table 1.....	3
Added Endnote 5 to Table 1; Renumbered Sequentially.....	3
Changes to Table 2.....	5
Added Figure 27, Figure 28, and Figure 29; Renumbered Sequentially	12
Changes to Floating Node Avoidance Section and Figure 36	17
Updated Outline Dimensions.....	21

2/2017—Rev. 0 to Rev. A

Changes to Features Section	1
Changes to On Resistance Parameter, Table 1.....	3
Change to Table 2	5
Changes to Figure 13 and Figure 14.....	8
Updated Outline Dimensions.....	20

1/2017—Revision 0: Initial Version

SPECIFICATIONS

Supply voltage (V_{DD}) = 3.1 V to 3.3 V, GND = 0 V, all specifications at $T_A = 25^\circ\text{C}$, unless otherwise noted. Typical specifications tested at $T_A = 25^\circ\text{C}$ with $V_{DD} = 3.3$ V.

Table 1.

Parameter	Symbol	Min	Typ	Max	Unit	Test Conditions/Comments ¹
DYNAMIC CHARACTERISTICS						
Operating Frequency		0/dc		13	GHz	
-3 dB Bandwidth	BW					
RF1, RF4		9.5	10.8		GHz	RF1 to RFC and RF4 to RFC channels
RF2, RF3		11.5	13		GHz	RF2 to RFC and RF3 to RFC channels
Insertion Loss	IL		0.45	0.6	dB	At 2.5 GHz, RFC to RFx
			0.63	0.95	dB	At 6.0 GHz, RFC to RFx
Isolation	RFx to RFC	22	24		dB	At 2.5 GHz, RFx to RFC (all channels off)
		16	19		dB	At 6.0 GHz, RFx to RFC (all channels off)
RF1 to RFC			27			At 6 GHz, RF2 to RFC is on, RF1 to RFC is off
RF2 to RFC			26			At 6 GHz, RF1 to RFC is on, RF2 to RFC is off
Crosstalk		27	30		dB	At 2.5 GHz, RFx to RFx
		22	24		dB	At 6.0 GHz, RFx to RFx
Return Loss	RL	14	17		dB	DC to 6.0 GHz
Third-Order Intermodulation Intercept	IIP3		67		dBm	Input: 900 MHz and 901 MHz, input power = 27 dBm
Second-Order Intermodulation Intercept	IIP2		95		dBm	Input: 900 MHz and 901 MHz, input power = 27 dBm
Second Harmonic	HD2		-90		dBc	Input: 5.4 MHz, input power = 0 dBm
			-74		dBc	Input: 150 MHz and 800 MHz, input power = 27 dBm
Third Harmonic	HD3		-80		dBc	Input: 150 MHz and 800 MHz, input power = 27 dBm
Total Harmonic Distortion plus Noise	THD + N		-102		dBc	$R_L = 300 \Omega$, $f = 1$ kHz, $RFx = 2.5$ V p-p
RF Input Power				32	dBm	Switch in the on state and terminated into 50Ω , 0°C to 85°C
DC Voltage Range		-6		+6	V	On switch dc voltage operation range, 0°C to 85°C
Switching Time						50% INx to 90% RFx, 50Ω termination, 0°C to 85°C
On	t_{ON}		30	75	μs	
Off	t_{OFF}		5	75	μs	
Settling Time						50% INx to 0.05 dB of final IL value, 50Ω termination
Rising Edge			40		μs	
Falling Edge			10		μs	
Actuation Frequency				5	kHz	All switches toggled simultaneously, 0°C to 85°C
Power-Up Time			0.55		ms	$C_{CP} = 47$ pF; 95% V_{DD} to 90% RFx, 0°C to 85°C
Video Feedthrough			16		mV peak	1 M Ω termination at RFx pin
Internal Oscillator Frequency		6		16	MHz	0°C to 85°C
Internal Oscillator Feedthrough ²			-115		dBm	Spectrum analyzer resolution bandwidth (RBW) = 200 Hz, one switch in on state, all other switches off with 50Ω terminations ³
				-138	dBm/Hz	

Parameter	Symbol	Min	Typ	Max	Unit	Test Conditions/Comments ¹
ON RESISTANCE PROPERTIES						
On Resistance	R_{ON}		1.8	3.5	Ω	Drain source current (I_{DS}) = 50 mA, 0 V input bias, at 1 ms after actuation, maximum specification from 0°C to 85°C
On Resistance Variation Over Actuations	ΔR_{ON}		1.4		Ω	10 ⁹ actuations, from 0°C to 85°C, 1 kHz cycling frequency, 220 mA load between toggles, see Figure 24 and Figure 25
Between Channels Over Time	$\Delta R_{ON\ CH_CH}$ $\Delta R_{ON\ TIME}$		0.25	1	Ω	Maximum value tested from 0°C to 85°C
On Resistance Repeatability	$\Delta R_{ON\ REP}$		0.01		Ω	R_{ON} change from 1 ms to 100 ms after actuation, maximum value tested from 0°C to 85°C, see Figure 22
On Resistance Input Voltage Bias	$\Delta R_{ON\ VBIAS}$		0.17		Ω	One on to off to on actuation cycle I_{DS} = 50 mA, from -6 V to +6 V input bias
CAPACITANCE PROPERTIES						
On Switch Channel Capacitance	$C_{RF\ ON}$		3		pF	At 1 MHz, includes LFCSP pin capacitance
Off Switch Channel Capacitance	$C_{RF\ OFF}$		1.5		pF	
LEAKAGE PROPERTIES						
On Leakage				5	nA	RFx (off channels) = -6 V, RFC to RFx (on channel) = -6 V, maximum specification from 0°C to 85°C RFx = 6 V, RFC = -6 V, maximum specification from 0°C to 85°C
Off Leakage				0.5	nA	
RELIABILITY PROPERTIES						
Continuously On Lifetime Actuation Lifetime		10 ⁹	7.2		Years Cycles	Median time before failure ⁴ at 50°C Cold switched, load between toggling is 220 mA, tested at 85°C
DIGITAL INPUTS						
Input High Voltage	V_{INH}	2			V	Minimum and maximum over 0°C to 85°C $V_{IN} = V_{INL}$ or V_{INH}
Input Low Voltage	V_{INL}			0.8	V	
Input Current	I_{INL}, I_{INH}		0.025	1	μ A	
POWER REQUIREMENTS						
Supply Voltage	V_{DD}	3.1		3.3	V	Minimum and maximum over 0°C to 85°C $V_{DD} = 3.3$ V, digital inputs = 0 V or V_{DD} This value is I_{DD} in low power mode
Supply Current	I_{DD}		3	4	mA	
Low Power Mode Current ⁵	$I_{DD\ EXT\ VCP}$			50	μ A	

¹ RFx is RF1, RF2, RF3, and RF4. INx is IN1, IN2, IN3, and IN4.

² Disable the internal oscillator to eliminate feedthrough.

³ The spectrum analyzer setup is as follows: RBW = 200 Hz, video bandwidth (VBW) = 2 Hz, span = 100 kHz, input attenuator = 0 dB, the detector type is peak, and the maximum hold is off. The fundamental feedthrough noise or harmonic (whichever is higher) is tested.

⁴ This value shows the median time it takes for 50% of a sample lot to fail.

⁵ For more details, see the Low Power Mode section.

ABSOLUTE MAXIMUM RATINGS

$T_A = 25^\circ\text{C}$, unless otherwise noted.

Table 2.

Parameter	Rating
V_{DD} to GND	-0.3 V to +6 V
Digital Inputs ¹	-0.3 V to $V_{DD} + 0.3$ V or 30 mA (whichever occurs first)
DC Voltage Rating ²	± 10 V
Standoff Voltage ³	20 V
Current Rating ²	250 mA
RF Power Rating ⁴	33 dBm
Operating Temperature Range	0°C to $+85^\circ\text{C}$
Storage Temperature Range	-65°C to $+150^\circ\text{C}$
Reflow Soldering (Pb-Free)	
Peak Temperature	260 (+0/-5) $^\circ\text{C}$
Time at Peak Temperature	10 sec to 30 sec
Electrostatic Discharge (ESD)	
Human Body Model (HBM)	
RF1 to RF4 and RFC Pins	5 kV
All Other Pins	2.5 kV
Field Induced Charged Device Model ⁵	
All Pins	1.25 kV
Group D	
Mechanical Shock (with 0.5 ms Pulse) ⁶	1500 g
Vibration (Acceleration at 50 g)	20 Hz to 2000 Hz
Constant Acceleration	30,000 g

¹ Clamp overvoltages at INx by internal diodes. Limit the current to the maximum ratings given.

² This rating is with respect to the switch in the on position with no radio frequency signal applied.

³ This rating is with respect to the switch in the off position.

⁴ This rating is with respect to the switch in the on position and terminated into 50 Ω . The rating is 27 dBm when the switch is unterminated.

⁵ A safe automated handling and assembly process is achieved at this rating level by implementing industry standard ESD controls.

⁶ If the device is dropped during handling, do not use the device.

Stresses at or above those listed under Absolute Maximum Ratings may cause permanent damage to the product. This is a stress rating only; functional operation of the product at these or any other conditions above those indicated in the operational section of this specification is not implied. Operation beyond the maximum operating conditions for extended periods may affect product reliability.

Only one absolute maximum rating can be applied at any one time.

THERMAL RESISTANCE

Thermal performance is directly linked to printed circuit board (PCB) design and operating environment. Careful attention to PCB thermal design is required.

θ_{JA} is the natural convection junction to ambient thermal resistance measured in a one cubic foot sealed enclosure. θ_{JC} is the junction to case thermal resistance.

Table 3. Thermal Resistance

Package Type	θ_{JA}	θ_{JC}	Unit
CP-24-4 ¹	60	75	$^\circ\text{C}/\text{W}$

¹ A simulated θ_{JA} number is evaluated using the maximum junction temperature in the package and the total power being dissipated in the package under operating conditions. For thermal performance calculation purposes at 25°C , a power dissipation of 113 mW per switch can be used. This value is calculated from a typical R_{ON} of 1.8 Ω and an absolute maximum current rating of 250 mA.

ESD CAUTION



ESD (electrostatic discharge) sensitive device. Charged devices and circuit boards can discharge without detection. Although this product features patented or proprietary protection circuitry, damage may occur on devices subjected to high energy ESD. Therefore, proper ESD precautions should be taken to avoid performance degradation or loss of functionality.

PIN CONFIGURATION AND FUNCTION DESCRIPTIONS

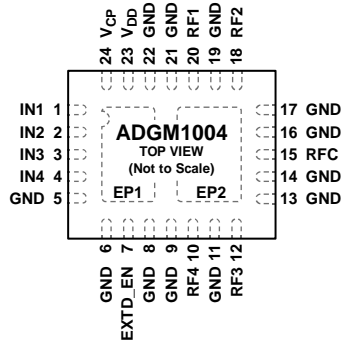

- NOTES**
1. EXPOSED PAD 1. EP1 IS INTERNALLY CONNECTED TO EP2 AND MUST BE CONNECTED TO GND.
 2. EXPOSED PAD 2. EP2 IS INTERNALLY CONNECTED TO EP1 AND MUST BE CONNECTED TO GND.

15173-002

Figure 2. Pin Configuration

Table 4. Pin Function Descriptions

Pin No.	Mnemonic	Description
1	IN1	Digital Control Input 1. The voltage applied to this pin controls the gate of the MEMS switch, RF1 to RFC. If IN1 is low, RF1 to RFC is open (off). If IN1 is high, connect RF1 to RFC (on).
2	IN2	Digital Control Input 2. The voltage applied to this pin controls the gate of the MEMS switch, RF2 to RFC. If IN2 is low, RF2 to RFC is open (off). If IN2 is high, connect RF2 to RFC (on).
3	IN3	Digital Control Input 3. The voltage applied to this pin controls the gate of the MEMS switch, RF3 to RFC. If IN3 is low, RF3 to RFC is open (off). If IN3 is high, connect RF3 to RFC (on).
4	IN4	Digital Control Input 4. The voltage applied to this pin controls the gate of the MEMS switch, RF4 to RFC. If IN4 is low, RF4 to RFC is open (off). If IN4 is high, connect RF4 to RFC (on).
5, 6, 8, 9, 11, 13, 14, 16, 17, 19, 21, 22	GND	Ground Connection.
7	EXTD_EN	External Voltage Drive Enable. In normal operation, set EXTD_EN low to enable the built in 11.5 MHz oscillator, which enables the internal driver IC voltage boost circuitry. Setting EXTD_EN high disables the internal 11.5 MHz oscillator and driver boost circuitry. With the oscillator disabled, the switch can still be controlled via the logic interface pins (IN1 to IN4), but the V _{CP} pin must be driven with 80 V dc from an external voltage supply. In this mode, the ADGM1004 only consumes 80 μA maximum supply current. Disabling the internal oscillator eliminates the associated 11.5 MHz noise feedthrough into the switch.
10	RF4	RF4 Port. This pin can be an input or an output. If unused, the pin must be connected to GND.
12	RF3	RF3 Port. This pin can be an input or an output. If unused, the pin must be connected to GND.
15	RFC	Common RF Port. This pin can be an input or an output.
18	RF2	RF2 Port. This pin can be an input or an output. If unused, the pin must be connected to GND.
20	RF1	RF1 Port. This pin can be an input or an output. If unused, the pin must be connected to GND.
23	V _{DD}	Positive Power Supply Input. For the recommend input voltage for this chip, see the Specifications section. Then, boost up this voltage internally to generate the voltage required to turn on the MEMS switch.
24	V _{CP}	Charge Pump Capacitor Terminal. The recommended shunt capacitor to ground value is 47 pF. If Pin 7 is high, an 80 V dc drive voltage must be input into V _{CP} to drive the switches.
	EP1	Exposed Pad 1. EP1 is internally connected to EP2 and must be connected to GND.
	EP2	Exposed Pad 2. EP2 is internally connected to EP1 and must be connected to GND.

TYPICAL PERFORMANCE CHARACTERISTICS

For Figure 16, Figure 17, and Figure 18, T50 refers to the number of cycles for 50% of the population to fail.

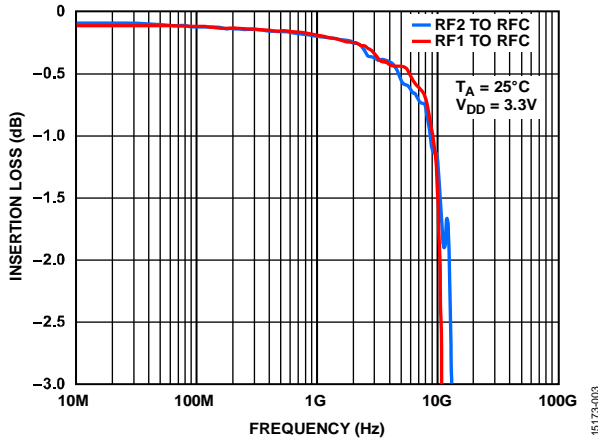

Figure 3. Insertion Loss vs. Frequency ($V_{DD} = 3.3\text{ V}$)

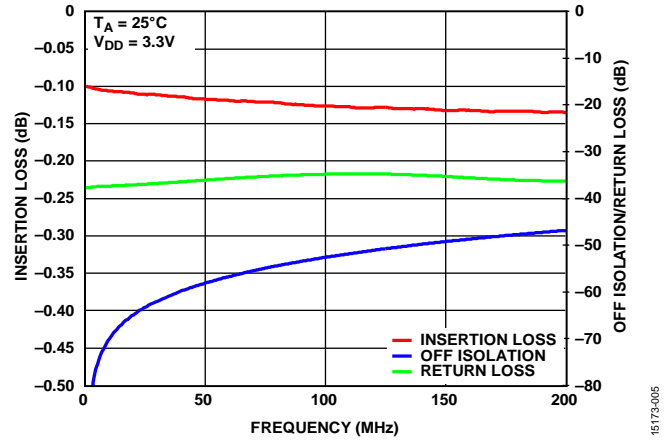

Figure 6. Insertion Loss and Off Isolation/Return Loss vs. Frequency ($V_{DD} = 3.3\text{ V}$, RF1 to RFC)

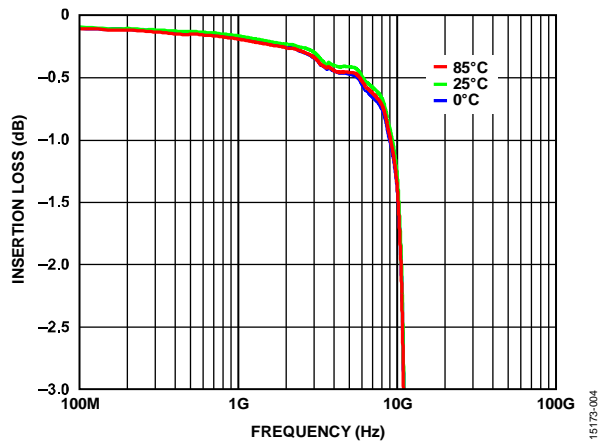

Figure 4. Insertion Loss vs. Frequency over Temperature ($V_{DD} = 3.3\text{ V}$, RF1 to RFC)

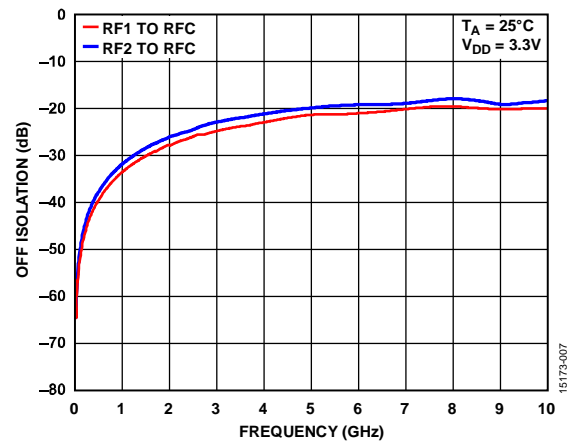

Figure 7. Off Isolation vs. Frequency, All Channels Off ($V_{DD} = 3.3\text{ V}$)

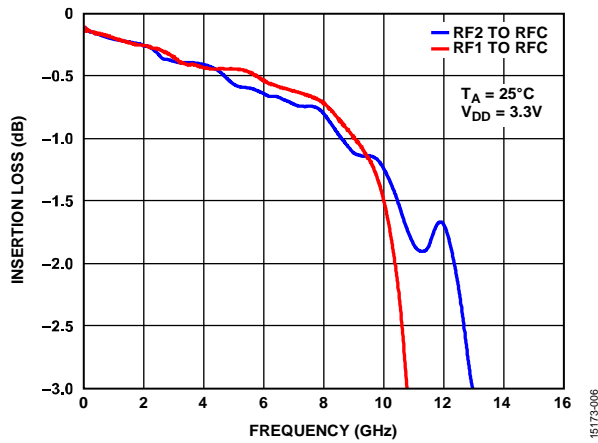

Figure 5. Insertion Loss vs. Frequency, Linear Scale ($V_{DD} = 3.3\text{ V}$)

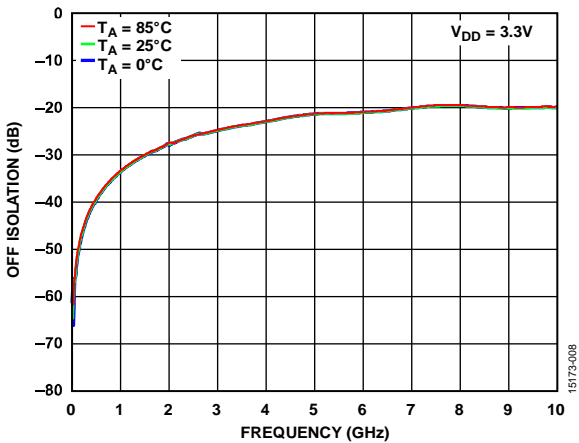

Figure 8. Off Isolation vs. Frequency over Temperature, All Channels Off ($V_{DD} = 3.3\text{ V}$, RF1 to RFC)

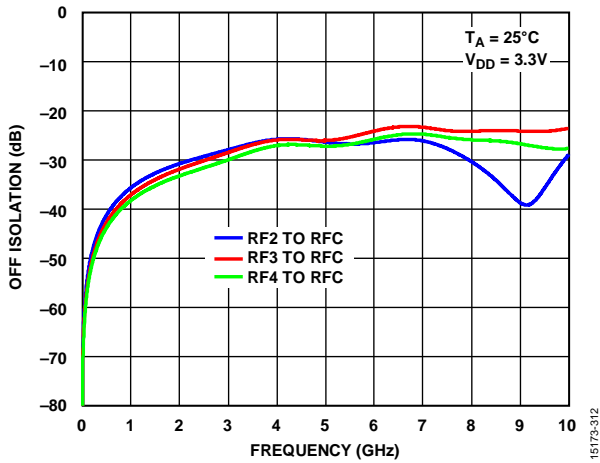

Figure 9. Off Isolation vs. Frequency, RF1 to RFC On ($V_{DD} = 3.3\text{ V}$)

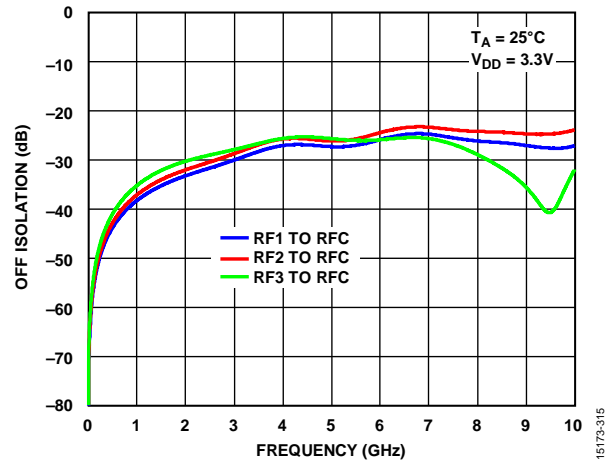

Figure 12. Off Isolation vs. Frequency, RF4 to RFC On ($V_{DD} = 3.3\text{ V}$)

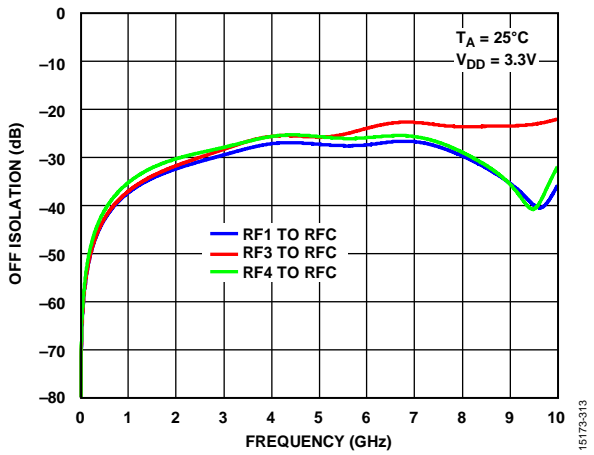

Figure 10. Off Isolation vs. Frequency, RF2 to RFC On ($V_{DD} = 3.3\text{ V}$)

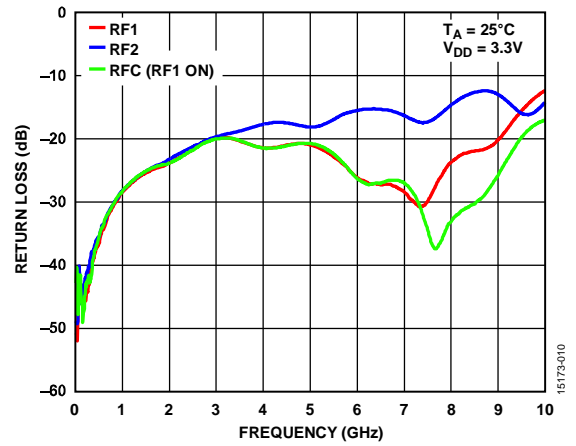

Figure 13. Return Loss vs. Frequency ($V_{DD} = 3.3\text{ V}$)

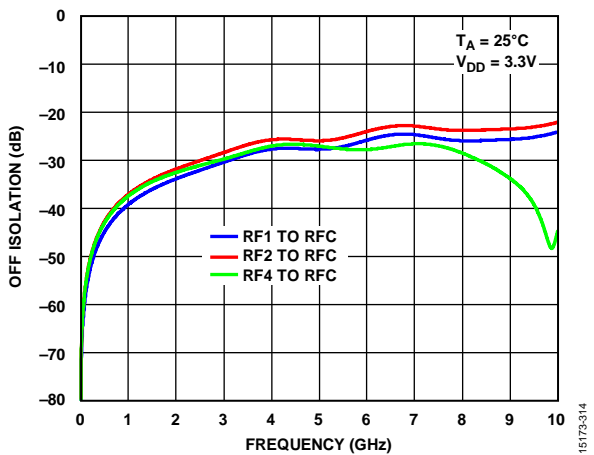

Figure 11. Off Isolation vs. Frequency, RF3 to RFC On ($V_{DD} = 3.3\text{ V}$)

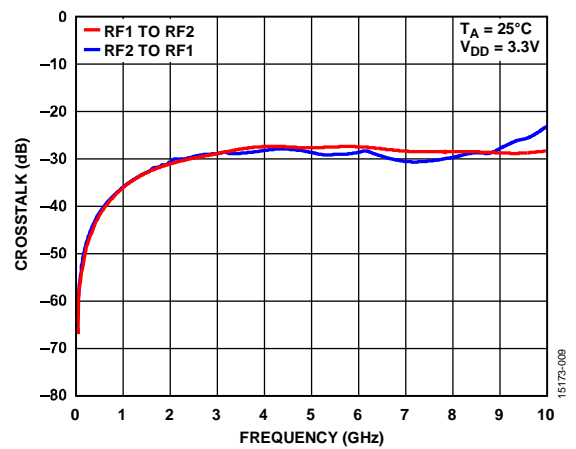

Figure 14. Crosstalk vs. Frequency ($V_{DD} = 3.3\text{ V}$)

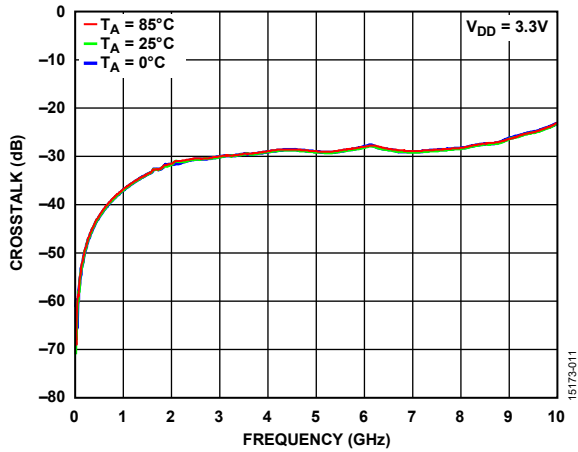

Figure 15. Crosstalk vs. Frequency over Temperature ($V_{DD} = 3.3\text{ V}$, RF2 to RF1)

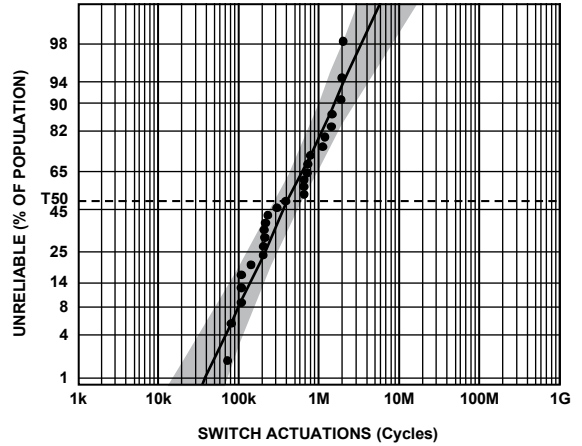

Figure 18. Log Normal Failure Probability with 95% CI Indicated for Hot Switching a 20 dBm CW Terminated to 50 Ω , $T_A = 25^\circ\text{C}$, $V_{DD} = 3.3\text{ V}$

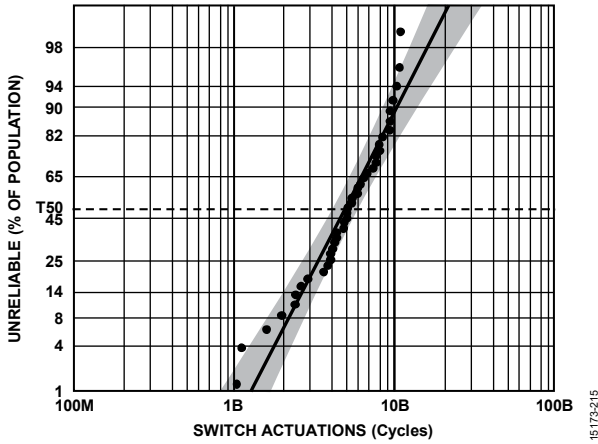

Figure 16. Log Normal Failure Probability with 95% Confidence Interval (CI) Indicated for Hot Switching a 10 dBm Continuous Wave (CW) Terminated to 50 Ω , $T_A = 25^\circ\text{C}$, $V_{DD} = 3.3\text{ V}$

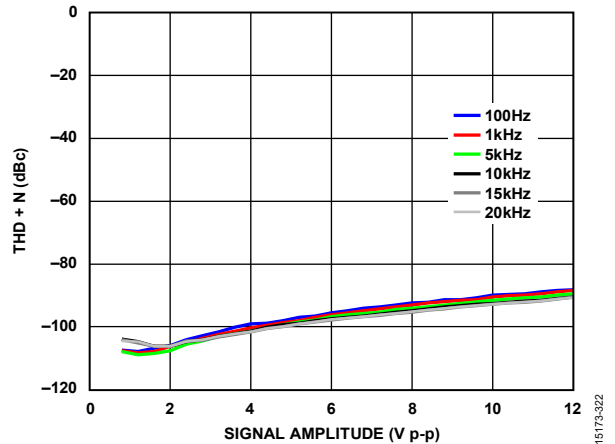

Figure 19. THD + N vs. Signal Amplitude ($V_{DD} = 3.3\text{ V}$, $R_{LOAD} = 300\ \Omega$, $T_A = 25^\circ\text{C}$, Output Source Impedance = 20 Ω)

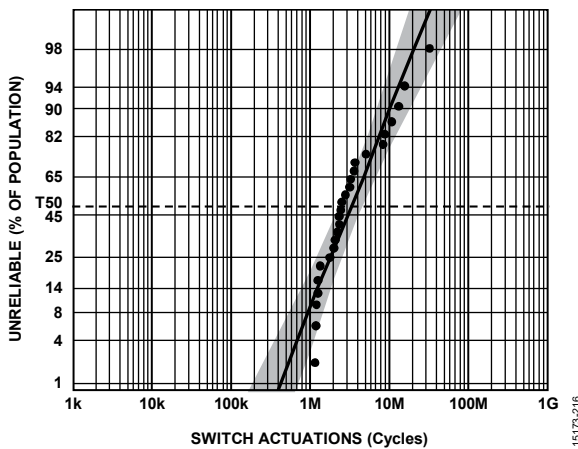

Figure 17. Log Normal Failure Probability with 95% CI Indicated for Hot Switching a 15 dBm CW Terminated to 50 Ω , $T_A = 25^\circ\text{C}$, $V_{DD} = 3.3\text{ V}$

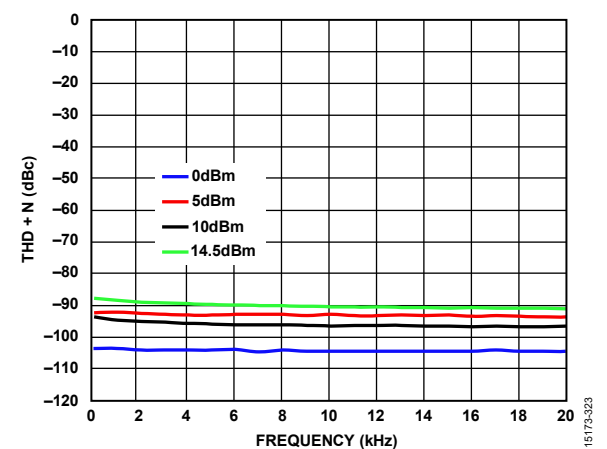

Figure 20. THD + N vs. Frequency ($V_{DD} = 3.3\text{ V}$, $R_{LOAD} = 300\ \Omega$, $T_A = 25^\circ\text{C}$, Output Source Impedance = 20 Ω)

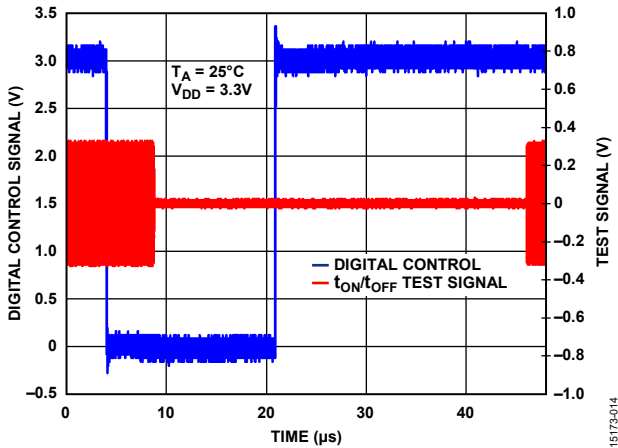

Figure 21. Digital Control Signal and Test Signal vs. Time ($V_{DD} = 3.3\text{ V}$)

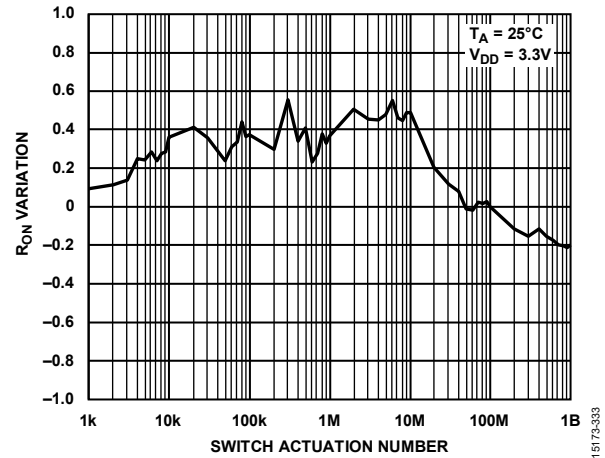

Figure 24. R_{ON} Variation vs. Switch Actuation Number ($V_{DD} = 3.3\text{ V}$, RF1 to RFC, Actuation Frequency = 1 kHz)

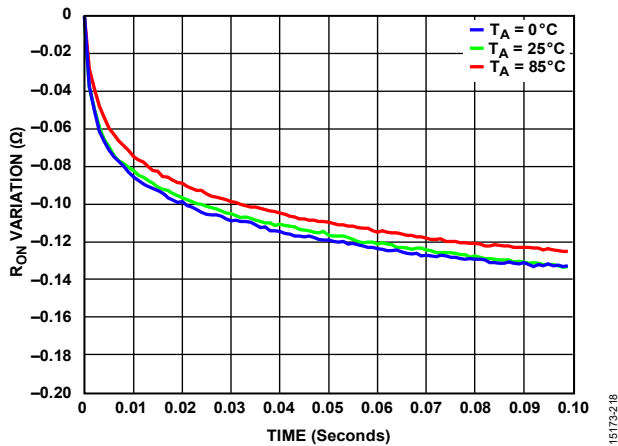

Figure 22. R_{ON} Variation vs. Time (1 ms to 100 ms) over Temperature ($V_{DD} = 3.3\text{ V}$, RF2 to RFC)

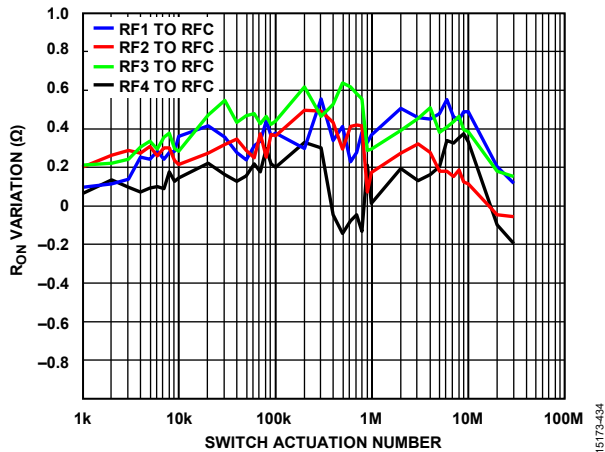

Figure 25. R_{ON} Variation vs. Switch Actuation Number, Across All Channels ($V_{DD} = 3.3\text{ V}$, Actuation Frequency = 1 kHz)

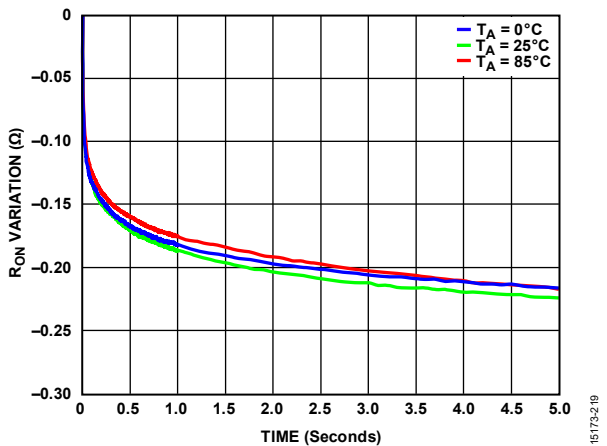

Figure 23. R_{ON} Variation vs. Time (1 ms to 5 sec) over Temperature ($V_{DD} = 3.3\text{ V}$, RF2 to RFC)

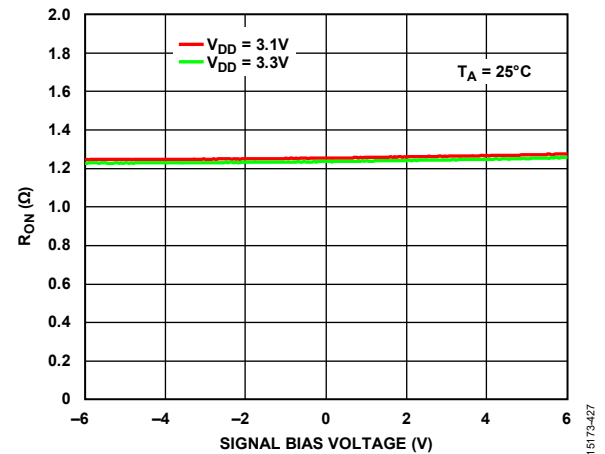

Figure 26. R_{ON} vs. Signal Bias Voltage over Supplies (Measured After 5 sec Post Switch Turn On)

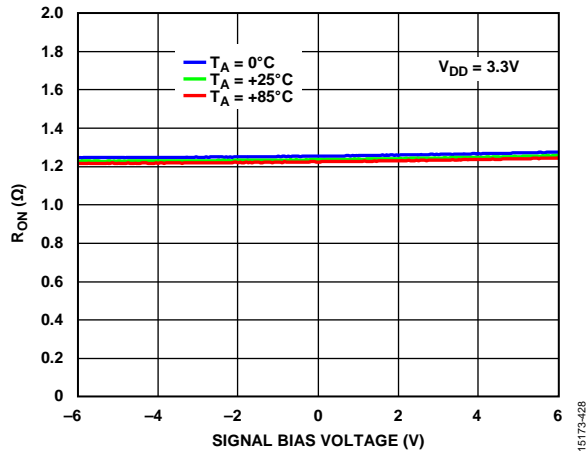

Figure 27. R_{ON} vs. Signal Bias Voltage over Temperature (Measured After 5 sec Post Switch Turn On)

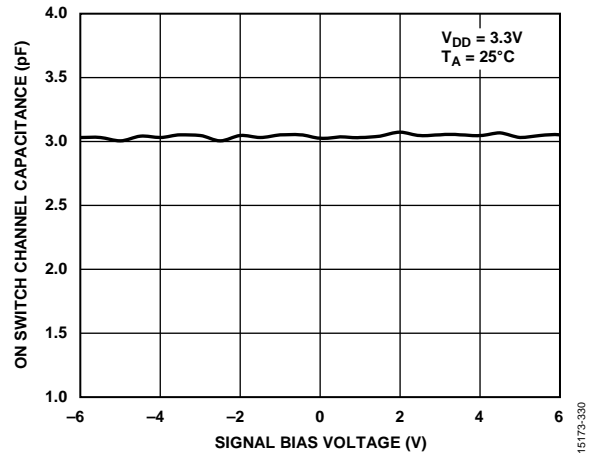

Figure 29. On Switch Channel Capacitance vs. Signal Bias Voltage (Signal Frequency = 1 MHz)

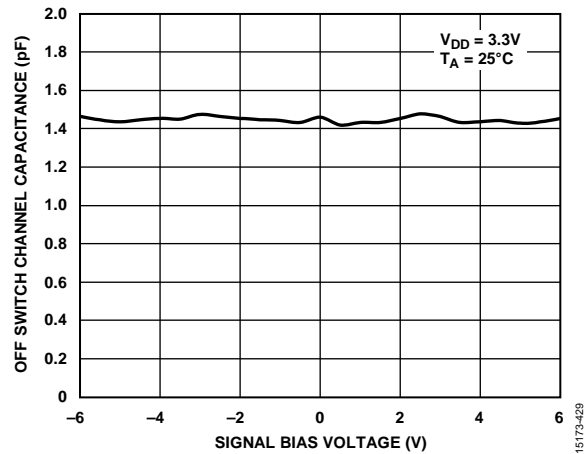

Figure 28. Off Switch Channel Capacitance vs. Signal Bias Voltage (Signal Frequency = 1 MHz)

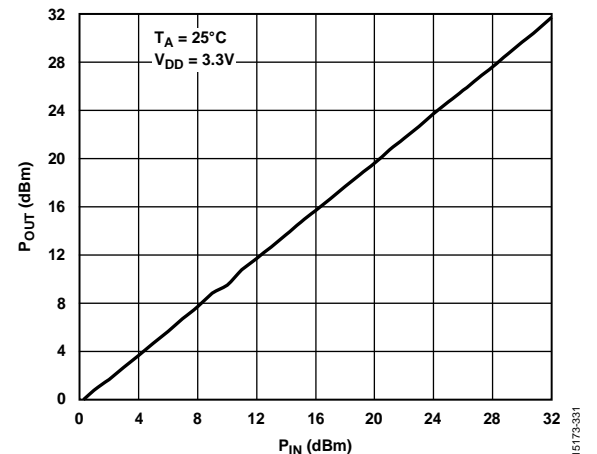

Figure 30. Output Power (P_{OUT}) vs. Input Power (P_{IN}) (Signal Frequency = 4 GHz)

TEST CIRCUITS

The test circuits shown in Figure 31 to Figure 42 are applicable to all channels. Additional pins are omitted for clarity.

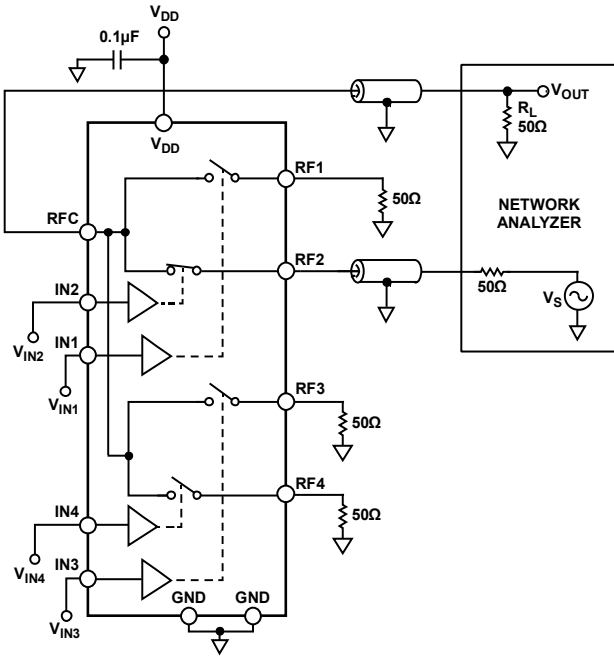

Figure 31. Insertion Loss and Return Loss

15173-015

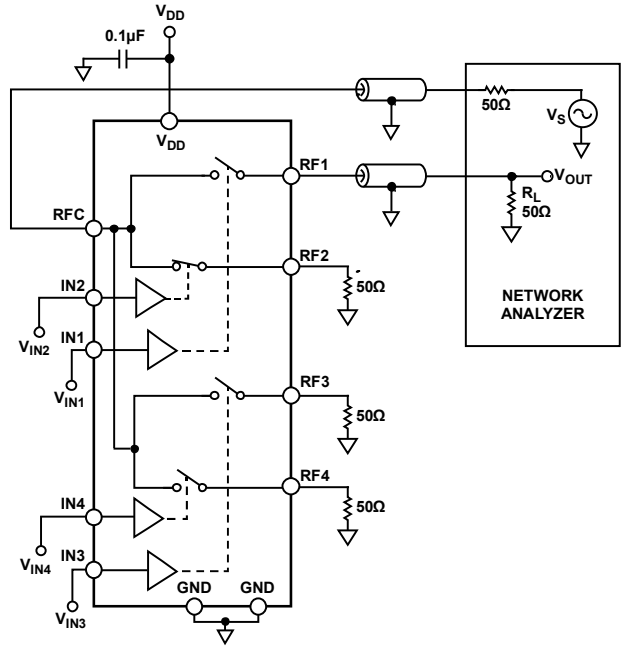

Figure 33. Isolation (RF2 to RFC is On, RF1 to RFC is Off)

15173-116

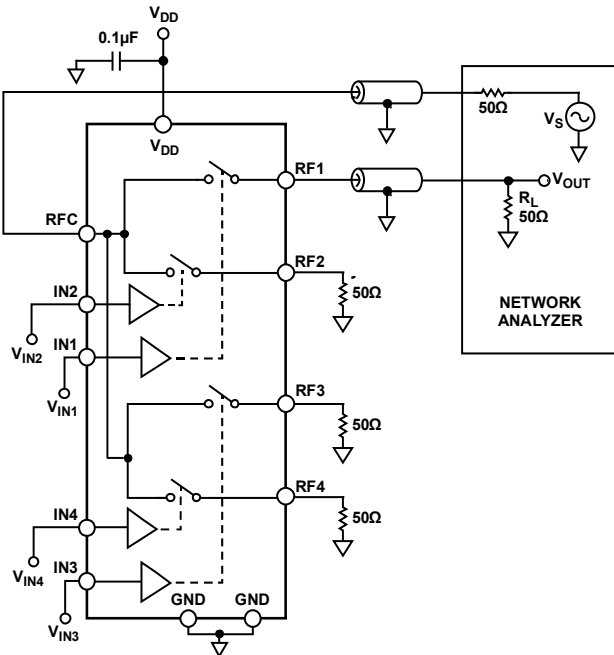

Figure 32. Isolation (All Switches Off)

15173-016

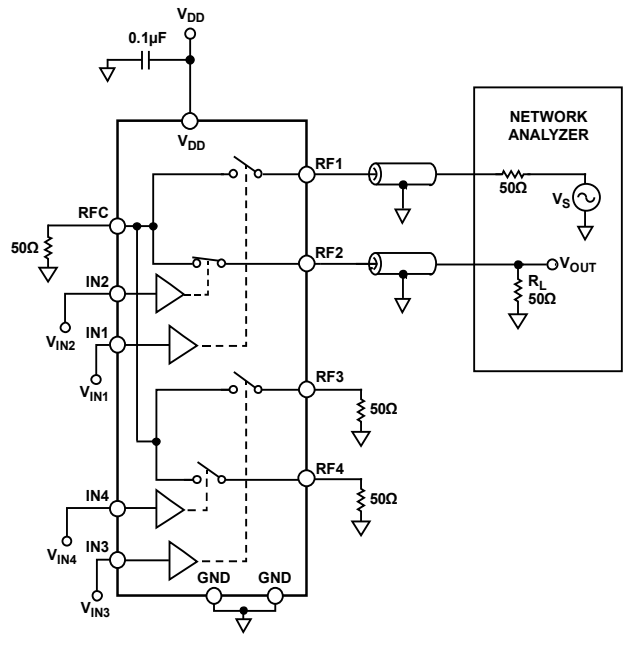

Figure 34. Crosstalk

15173-017

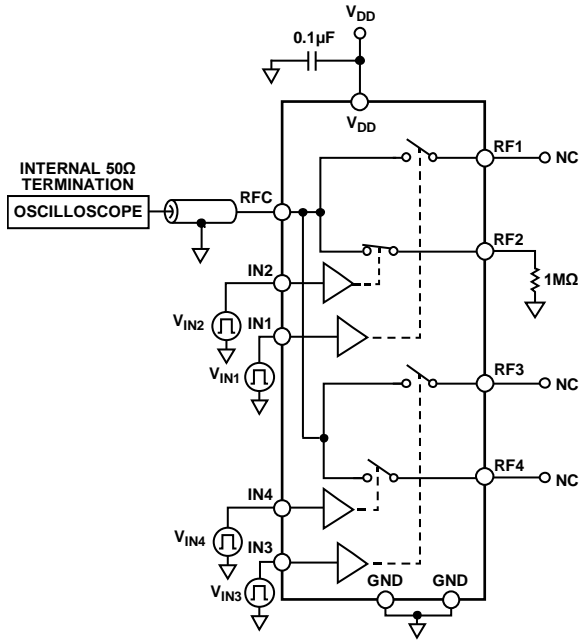

Figure 35. Video Feedthrough

15173-018

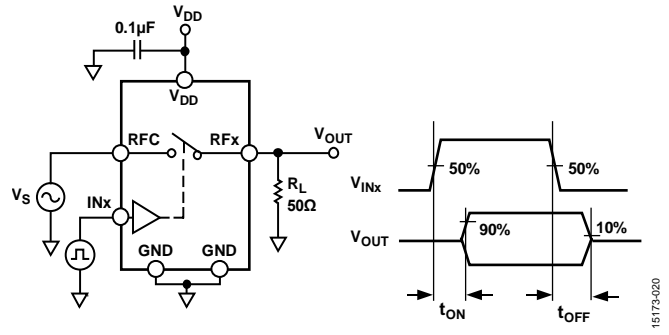

Figure 37. Switch Timing, t_{ON} and t_{OFF} (All RFx Terminals are Connected to 50 Ω Termination)

15173-020

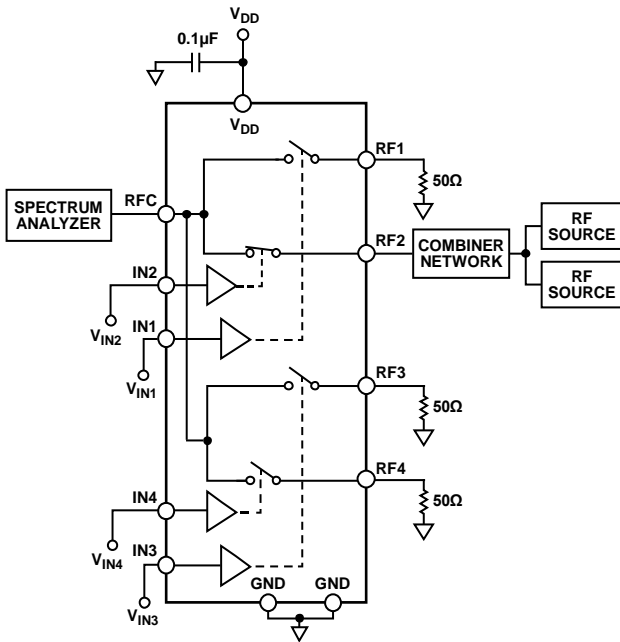

Figure 36. IIP2 and IIP3

15173-019

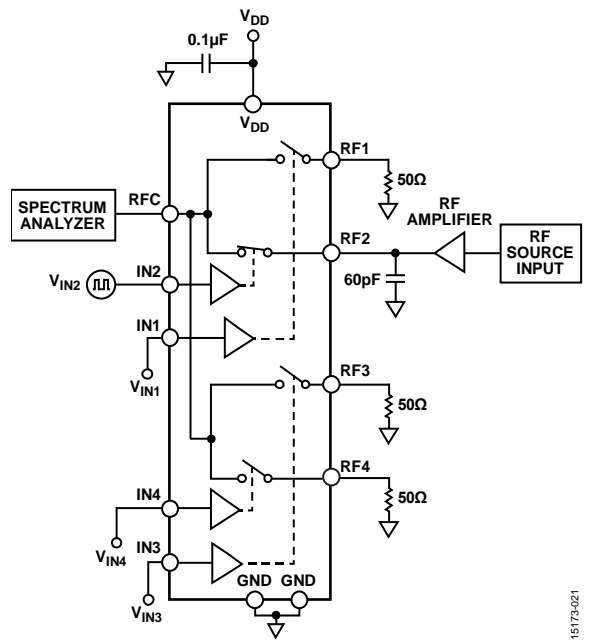

Figure 38. Hot Switching Evaluation Setup, 2 GHz RF Source, 50% Duty Cycle, 5 kHz Switching Actuation Speed

15173-021

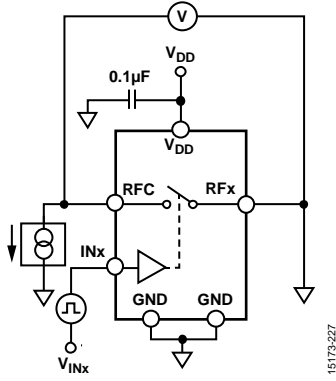

Figure 39. On Resistance

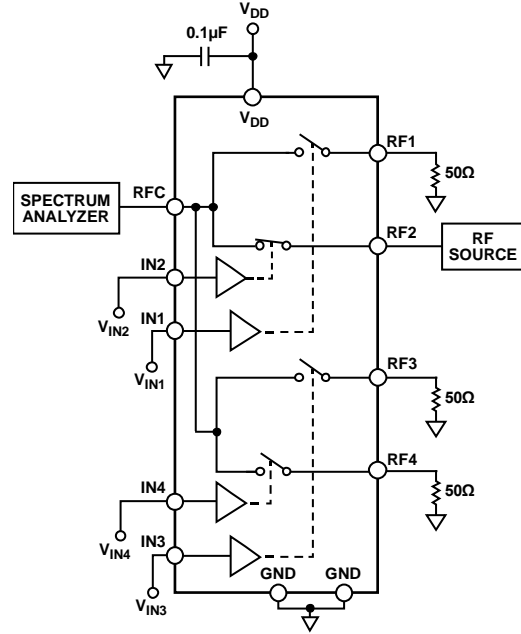
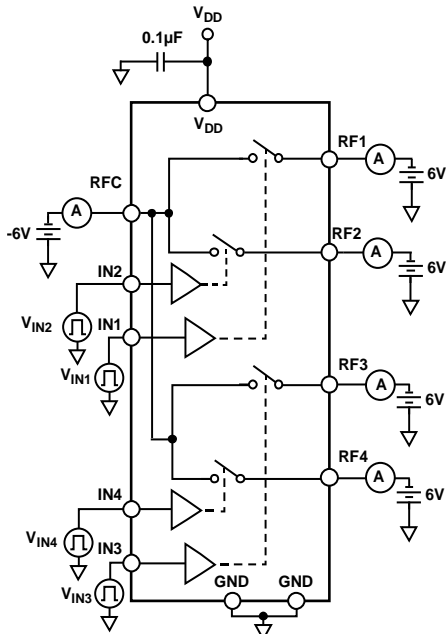
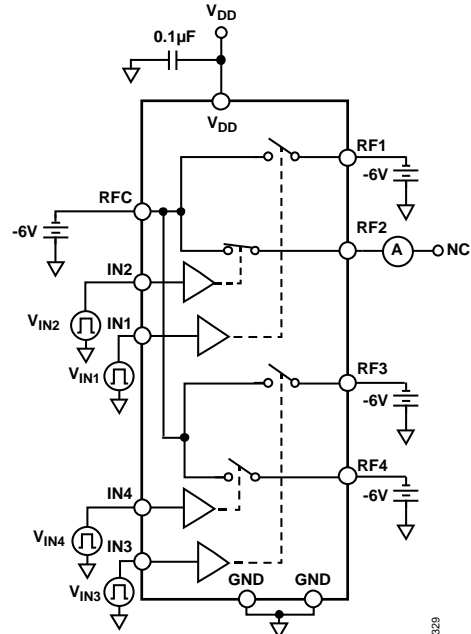

Figure 41. Second and Third Harmonics, RF Power



NC = NO CONNECT
Figure 40. Off Leakage



NC = NO CONNECT
Figure 42. On Leakage

TERMINOLOGY

Insertion Loss (IL)

IL is the amount of signal attenuation between the input and output ports of the switch when the switch is in the on state. Expressed in decibels, ensure that insertion loss is as small as possible for maximum power transfer.

An example calculation of insertion loss based on the setup in Figure 31 is as follows:

$$IL \text{ (dB)} = -20\log_{10}|S_{RF2RFC}|$$

where S_{RF2RFC} is the transmission coefficient measured from RF2 to RFC with RF2 in the on position. All unused switches are in the off position and terminated in a purely resistive load of 50 Ω .

Isolation

Isolation is the amount of signal attenuation between the input and output ports of the switch when the switch is in the off state. Expressed in decibels, ensure that isolation is as large as possible.

An example calculation of isolation based on the setup in Figure 32 is as follows:

$$Isolation \text{ (dB)} = -20\log_{10}|S_{RFCRF1}|$$

where S_{RFCRF1} is the transmission coefficient measured from RFC to RF1 with RF1 in the off position. All unused switches are in the off position and terminated in a purely resistive load of 50 Ω .

Crosstalk

Crosstalk is a measure of unwanted signals coupled through from one channel to another because of parasitic capacitance.

An example calculation of crosstalk based on the setup in Figure 34 is as follows:

$$Crosstalk \text{ (dB)} = -20\log_{10}|S_{RF1RF2}|$$

where S_{RF1RF2} is the transmission coefficient measured from RF1 to RF2 with RF1 in the off position and RF2 in the on position. All unused switches are in the off position and terminated in a purely resistive load of 50 Ω .

Return Loss (RL)

RL is the magnitude of the reflection coefficient expressed in decibels, and the amount of reflected signal relative to the incident signal.

An example calculation of return loss based on the setup in Figure 31 is as follows:

$$RL \text{ (dB)} = -20\log_{10}|S_{11}|$$

where S_{11} is the reflection coefficient of the port under test.

Third-Order Intermodulation Intercept (IIP3)

IIP3 is the intersection point of the fundamental P_{OUT} vs. P_{IN} extrapolated line and the third-order intermodulation products extrapolated line of a two-tone test. IIP3 is a figure of merit that characterizes the switch linearity.

Second-Order Intermodulation Intercept (IIP2)

IIP2 is the intersection point of the fundamental P_{OUT} vs. P_{IN} extrapolated line and the second-order intermodulation products extrapolated line of a two-tone test. IIP2 is a figure of merit that characterizes the switch linearity.

Second Harmonic (HD2)

HD2 is the amplitude of the second harmonic, where, for a signal whose fundamental frequency is f , the second harmonic has a frequency of $2f$. This measurement is a single-tone test, expressed with reference to the carrier signal (dBc).

Third Harmonic (HD3)

HD3 is the amplitude of the third harmonic, where, for a signal whose fundamental frequency is f , the third harmonic has a frequency of $3f$. This measurement is a single tone test, expressed with reference to the carrier signal (dBc).

On Switching Time (t_{ON})

t_{ON} is the time it takes for the switch to turn on. It is measured from 50% of the control signal (IN_x) to 90% of the on level. No power was applied through the switch during this test (cold switched). The switch was terminated into a 50 Ω load.

Off Switching Time (t_{OFF})

t_{OFF} is the time it takes for the switch to turn off. It is measured from 50% of the control signal (IN_x) to 10% of the on level. No power was applied through the switch during this test (cold switched). The switch was terminated into a 50 Ω load.

Settling Time Rising Edge

The settling time rising edge is the time it takes for the power of an RF signal to settle within 0.05 dB of its final steady state value. The switch was terminated into a 50 Ω load.

Settling Time Falling Edge

The settling time falling edge is the time it takes for the power of an RF signal to settle within 0.05 dB of its final steady state value. The switch was terminated into a 50 Ω load.

Actuation Frequency

The actuation frequency refers to the speed at which the ADGM1004 can be switched on and off. Actuation frequency is dependent on both settling times and on switching time and off switching time.

Power-Up Time

The power-up time is a measure of the time required for the device to power up and start to pass 90% of an RF input signal after the V_{DD} pin has reached 95%.

Video Feedthrough

Video feedthrough is a measure of the spurious signals present at the RF $_x$ ports of the switch when the control voltage is switched from high to low or from low to high without an RF signal present.

Internal Oscillator Frequency

The internal oscillator frequency is the value of the on-board oscillator that drives the gate control chip of the ADGM1004.

Internal Oscillator Feedthrough

The internal oscillator feedthrough is the amount of internal oscillator signal that feeds through to the RFX and RFC pins of the switch. This signal appears as a noise spur on the RFX and RFC pins of the switch at the frequency the oscillator is operating at and harmonics thereof.

On Resistance (R_{ON})

R_{ON} is the resistance of a switch in the closed/on state measured between the package pins. Measure resistance in 4-wire mode to null out any cabling or PCB series resistances.

On Resistance Variation

On resistance variation is the variation in the on resistance of the switch over the specified criteria in Table 1.

Continuously On Lifetime

The continuously on lifetime parameter measures how long the switch is left in a continuously on state. If the switch is left in the on position for an extended period, it affects the turn off mechanism of the device.

Actuation Lifetime

Actuation lifetime is the number of consecutive open/close/open cycles that can complete without the on resistance exceeding a specified limit and no occurrence of failures to open (FTO) or failures to close (FTC).

Cold Switching

Cold switching operates the switch in a mode so that no voltage differential exists between source and drain when the switch is closed and/or no current is flowing source to drain when the switch opens. All switches have longer lives when cold switched.

Hot Switching

Hot switching is operating the switch in a mode where a voltage differential exists between source and drain when the switch is closed and/or current is flowing RFX to RFC when the switch is opened. Hot switching results in a reduced switch life, depending on the magnitude of the open circuit voltage between the source and the drain.

Input High Voltage (V_{INH})

V_{INH} is the minimum input voltage for Logic 1.

Input Low Voltage (V_{INL})

V_{INL} is the maximum input voltage for Logic 0.

Input Current (I_{INL} , I_{INH})

I_{INL} and I_{INH} are the low and high input currents of the digital inputs.

Low Power Mode Current ($I_{DD\ EXT\ VCP}$)

$I_{DD\ EXT\ VCP}$ is the amount of supply current used by the gate driver circuitry when the internal oscillator and the charge pump circuitry is disabled by setting the EXTD_EN pin high.

THEORY OF OPERATION

The ADGM1004 is a wideband SP4T switch fabricated using Analog Devices MEMS switch technology. This technology enables high power, low loss, low distortion GHz switches to be used in demanding RF applications.

A key strength of the MEMS switch is that it simultaneously brings together high frequency RF performance and 0 Hz/dc precision performance. This combination, coupled with superior reliability and a tiny surface-mountable form factor, make the MEMS switch the ideal switching solution for all RF and precision signal instrumentation needs.

Figure 43 shows a cross section of the switch with dimensions. The switch is an electrostatically actuated cantilever beam connected in a 3-terminal configuration. Functionally, it is analogous to a field effect transistor (FET). The terminals can be used as a source, gate, and drain.

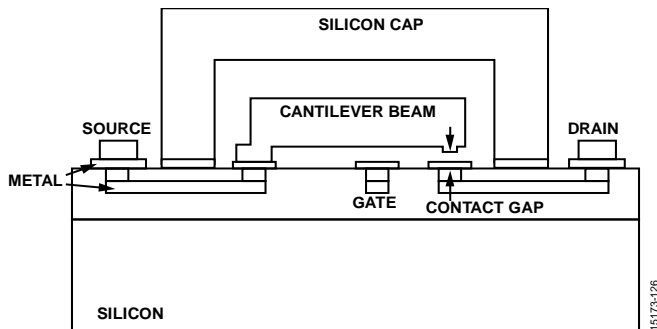

Figure 43. Cross Section of the MEMS Switch Design Showing the Cantilever Switch Beam (Not to Scale)

When a dc actuation voltage is applied between the gate electrode and the source (the switch beam), an electrostatic force is generated, resulting in attracting the beam toward the substrate. A separate on-board driver IC generates the 80 V bias voltage used for actuation.

When the bias voltage between the gate and the source exceeds the threshold voltage of the switch, V_{TH} , the contacts on the beam touch the drain, which completes the circuit between the source and the drain and turns the switch on. When the bias voltage is removed, that is, 0 V on the gate electrode, the beam acts as a spring generating a sufficient restoring force to open the connection between the source and the drain, thus breaking the circuit and turning the switch off.

The silicon cap covering the switch die is shown in Figure 43. This cap hermetically seals the switch, which improves reliability. The switch contacts do not suffer from dry switching or low power switching lifetime degradation.

DIGITAL INTERFACE

The ADGM1004 is controlled via a parallel digital interface. Standard CMOS/LVTTL signals applied through this interface control the actuation or release of all of the switch channels of the ADGM1004. Gate signals applied are boosted to provide the required voltages needed to actuate the MEMS switch.

Pin 1 to Pin 4 (IN1 to IN4) control the switching functions of the ADGM1004. When a Logic 1 is applied to one of these pins, the gate of the corresponding switch is activated, and the switch turns on. Conversely, when a Logic 0 is applied to any of these pins, the switch turns off. Note that it is possible to connect more than one RFx input to RFC at a time. The truth table for the ADGM1004 is given in Table 5.

Table 5. Truth Table

IN1	IN2	IN3	IN4	RF1 to RFC	RF2 to RFC	RF3 to RFC	RF4 to RFC
0	0	0	0	Off	Off	Off	Off
0	0	0	1	Off	Off	Off	On
0	0	1	0	Off	Off	On	Off
0	0	1	1	Off	Off	On	On
0	1	0	0	Off	On	Off	Off
0	1	0	1	Off	On	Off	On
0	1	1	0	Off	On	On	Off
0	1	1	1	Off	On	On	On
1	0	0	0	On	Off	Off	Off
1	0	0	1	On	Off	Off	On
1	0	1	0	On	Off	On	Off
1	0	1	1	On	Off	On	On
1	1	0	0	On	On	Off	Off
1	1	0	1	On	On	Off	On
1	1	1	0	On	On	On	Off
1	1	1	1	On	On	On	On

INTERNAL OSCILLATOR

The ADGM1004 has an internal oscillator running at a nominal 11.5 MHz. This oscillator drives the charge pump circuitry that provides the actuation voltage for each of the switch gate electrodes. Although this oscillator is very low power, the 11.5 MHz signal is coupled to the switch and can be considered a noise spur on the switch channels. The magnitude of this feedthrough noise spur is specified in Table 1 and is typically -115 dBm or -138 dBm/Hz when one switch is on. When all four switches are simultaneously on, the feedthrough goes up to -94 dBm. V_{DD} level and temperature changes affect the frequency of the noise spur. For the maximum and minimum frequency range over temperature and voltage supply range, see Table 1.

OSCILLATOR FEEDTHROUGH MITIGATION

In normal operation, the 80 V actuation voltage is supplied by the driver IC. Setting the EXT_D_EN pin (Pin 7) low enables the built in 11.5 MHz oscillator. This setting enables the charge pump circuitry to generate the 80 V required for MEMS switch actuation. The internal oscillator is a source of noise which couples through to the RF ports. The magnitude of this feedthrough noise spur is specified in Table 1 and is typically -115 dBm or -138 dBm/Hz when one switch is on. The internal oscillator feedthrough can be eliminated by setting the EXT_D_EN pin high, which disables the internal oscillator and charge pump circuitry. When the internal oscillator and charge pump circuitry is disabled, the V_{CP} pin (Pin 24) must be driven with 80 V dc (V_{CP,EXT}) from an external voltage supply, as

outlined in Table 4, required for MEMS switch actuation. The switch can still be controlled via the digital logic interface pins.

LOW POWER MODE

Setting the EXT_D_EN pin high shuts down the internal oscillator. The ADGM1004 enters a low power quiescent state, drawing only 50 μ A maximum supply current.

TYPICAL OPERATING CIRCUIT

Figure 44 shows the typical operating circuit for the ADGM1004 as used in the EVAL-ADGM1004EBZ evaluation board. A 47 pF (100 V rated) external capacitor (C_{CP}) is required on the V_{CP} pin. This capacitor is a holding capacitor for the 80 V dc gate drive voltage.

In the circuit shown in Figure 44, V_{DD} is connected to 3.3 V. EP1 connects to EP2 internally. Typically, one large GND pad on the PCB is used to short together EP1 and EP2. Figure 44 shows the ADGM1004 configured to use the internal oscillator as the reference clock to the driver IC control circuit. Alternatively, set Pin 7 high and apply 80 V dc directly to Pin 24 to disable the internal oscillator and eliminate all oscillator feedthrough. The switches can then be controlled as normal via the logic control interface, Pin 1 to Pin 4.

To avoid any floating nodes, it is recommended to connect a 10 M Ω shunt resistor to RFGND on all the RF pins (RF1, RF2, RF3, RF4, and RFC), as shown in Figure 44. For more information, refer to the Floating Node Avoidance section.

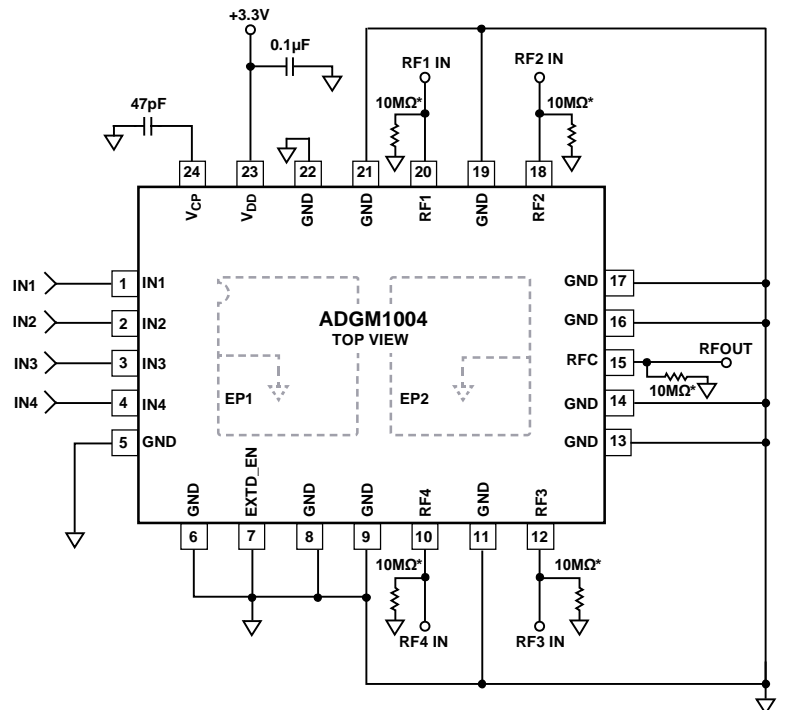

*10M Ω RESISTORS ARE REQUIRED TO AVOID ANY FLOATING NODES. FOR MORE INFORMATION, REFER TO THE APPLICATIONS INFORMATION SECTION

15173-350

Figure 44. Typical Operating Circuit

APPLICATIONS INFORMATION

FLOATING NODE AVOIDANCE

As described in the Theory of Operation section, to actuate the switch, 80 V dc is generated internally in the ADGM1004 device and applied to a gate electrode, which creates the electrostatic attraction force that actuates the switch. Without an external impedance to a dc voltage reference, charges can increase on the switch terminals, causing voltages to float to unknown levels, which can lead to unreliable actuation behavior that may damage the switch. To ensure correct and reliable switch actuation, ensure that all switch nodes have a dc voltage reference such as a connection to another active component with an internal voltage reference or an impedance to ground. Figure 45 to Figure 48 show examples of four cases to avoid where floating nodes can occur when using the switch. These cases include the following conditions:

- RFX pins must not be open circuit.
- A series capacitor connected directly to the switch can result in a floating node condition.
- Connecting the RFX pin of two switches directly together or RFC to RFX can result in a floating node condition.

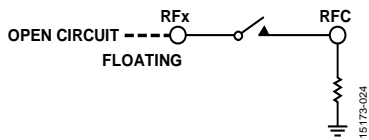

Figure 45. RFX Left Open Circuit

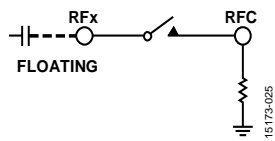

Figure 46. Series Capacitor Connected Directly to the Switch Can Result in a Floating Node Condition

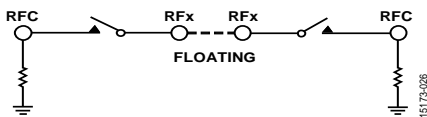

Figure 47. Connecting the RFX Pin of Two Switches Directly Together Can Result in a Floating Node Condition

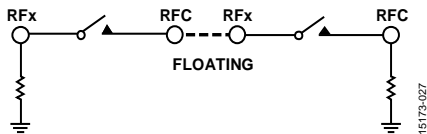

Figure 48. Connecting RFC to RFX Can Result in a Floating Node Condition

Providing a dc voltage reference to the switch ensures a correct gate to beam voltage differential to drive the switch and prevents unreliable actuation. In a typical application, a 50 Ω termination connected to the switch provides a constant dc voltage reference. Most amplifiers and other active devices also have an internal dc voltage reference. Therefore, when they are connected directly to the switch, they provide a dc voltage reference and avoid any floating node issues. If there is no inherent dc voltage

reference in the application circuit, a 10 MΩ shunt resistor or inductor on the source (RFX) pin of the MEMS switch must be added to provide a voltage reference. The addition of external shunt resistors increases the leakage above the specification shown in Table 1. Figure 49 shows this type of voltage reference configuration.

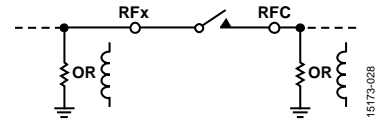

Figure 49. Switch Configuration Providing a Voltage Reference

A floating node condition on the RFC pin must also be avoided. If RFC is left floating to an unknown voltage level when the switch is off, there is a hot switching risk when the switch is subsequently toggled on. A 10 MΩ shunt resistor can be used to mitigate floating node risks on the RFC pin.

Figure 50 and Figure 51 illustrate typical cascaded switch use cases and the corresponding schemes to mitigate floating node risks. The path between the two switches needs a voltage reference to ground. Otherwise, the path can float to an unknown voltage and subsequently cause unreliable actuations, possibly leading to hot switching events or switches remaining in the on state.

To avoid hot switching events or switches remaining in the on state, add high value resistors (typically 10 MΩ) to ground to the channel of the MEMS switch, which is cascaded to another MEMS switch, as shown in Figure 50 and Figure 51. These shunt resistors create a dc voltage reference.

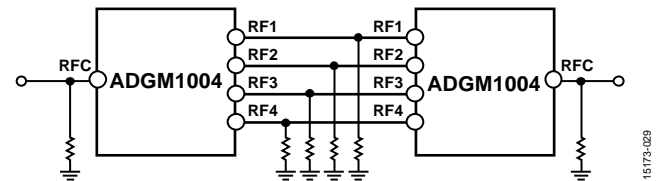

Figure 50. Two ADGM1004 Devices Connected Together with Shunt Resistors to Mitigate Floating Nodes

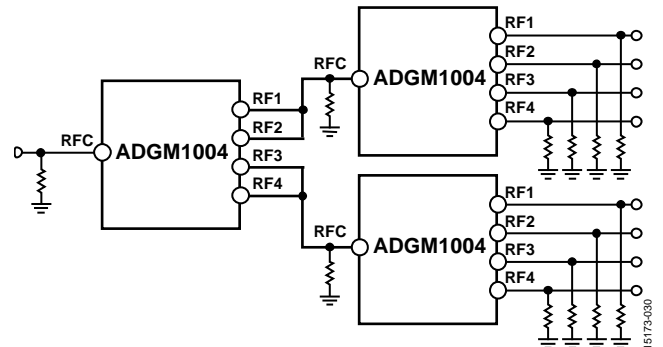

Figure 51. Three ADGM1004 Devices Connected Together with Shunt Resistors to Mitigate Floating Nodes

Avoid connecting large shunt capacitors directly to the switch where possible. A capacitor can store a charge and can potentially give rise to hot switching events when the switch opens or closes where there are no alternative discharge paths, which affects the cycle lifetime of the switch.

CONTINUOUSLY ON LIFETIME

If the switch channel is in the on state for extended periods of time (more than seven years), the switch can fail to turn off due to mechanical degradation effects. The continuously on lifetime feature is duty cycle dependent. In low duty cycle uses cases (for example, 10% on, 90% off), there is no lifetime degradation.

The ADGM1004 has a continuous on lifetime specification of 7.2 years (typical) at 50°C (see Table 1).

Figure 52 shows the extrapolated failure time of 31 switches where all of them were held in the on state continuously at 50°C until they failed to open. The lifetime is affected by temperature. As the temperature increases above 50°C, the continuously on lifetime degrades significantly. However, for lower temperatures, the lifetime improves.

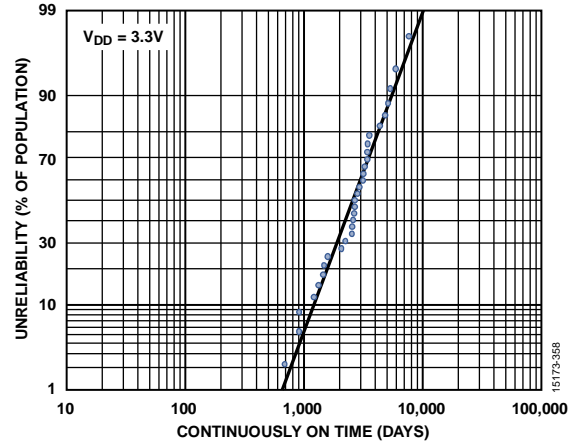

Figure 52. Continuously On Lifetime, $V_{DD} = 3.3\text{ V}$, 50°C, Sample Size = 31 Devices

SUGGESTED APPLICATION CIRCUITS

SWITCHABLE RF ATTENUATOR

RF attenuator networks are commonly used in RF instrumentation equipment, such as vector network analyzers, spectrum analyzers, and signal generators. Routing RF signals through an attenuator can enable the equipment to accept higher power signals and, therefore, increase the dynamic range of the instrument. In RF attenuation applications like the vector network analyzers, spectrum analyzers, and signal generators, maintaining the bandwidth of the signal after it passes through the network is critical. Any degradation of the signal reduces the performance of the equipment. Therefore, the RF characteristics of the switches used for routing are an integral part of the quality of an attenuator network.

The ADGM1004 MEMS switch with low flat insertion loss, wide RF bandwidth, and high reliability is suited for use as a switchable RF attenuator. The ADGM1004, as an SP4T switch, also brings added flexibility. Figure 53 shows an example attenuation network configuration using two ADGM1004 switches and three different attenuators. The fourth channel of the switches is used as a nonattenuated route in Figure 53.

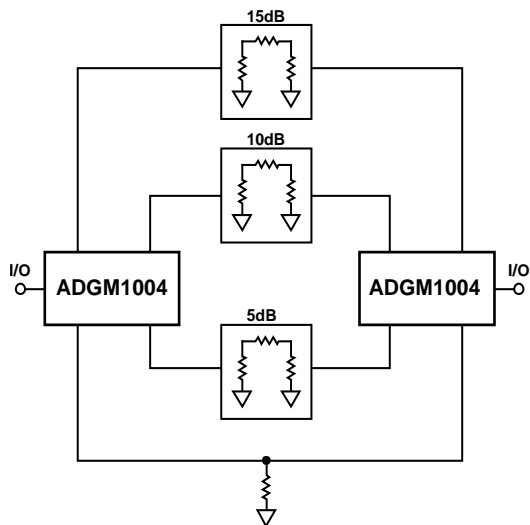

Figure 53. Switching RF Attenuators Using ADGM1004 MEMS Switches

RECONFIGURABLE RF FILTER

A reconfigurable RF filter is advantageous in many RF front-end applications. A reconfigurable RF filter provides more saved space. As space becomes more constrained in applications, the option to have an economical reconfigurable RF filter instead of individual frequency dependent filters is attractive.

The ADGM1004, with its low flat insertion loss, wide RF bandwidth, low parasitic, low capacitance, and high linearity, is needed to turn on the lump components (capacitor, inductor), which make the MEMS switch suited for reconfigurable filter application.

In applications such as wireless communications or mobile radios, the number of bands and/or modes constantly increases. A reconfigurable RF filter allows more bands and/or modes to be covered using the same components.

Figure 54 shows an example of a reconfigurable band-pass filter. The topology shown is of a generalized two-section, inductively coupled, single-ended band-pass filter, nominally centered on 400 MHz ultrahigh frequency (UHF) band. The MEMS switches are positioned in series with each of the shunt inductors.

The function of the switches includes or omits a shunt inductor from the circuit. Changing the shunt inductor value affects the bandwidth and center frequency of the filter. Using inductance values from 15 nH to 30 nH significantly alters the bandwidth and center frequency, allowing the filter to dynamically configure to operate in the UHF or very high frequency (VHF) bands while preserving the 50 Ω match on the input and output ports. The low R_{ON} value and wide bandwidth of the MEMS switch makes it an ideal choice for this application. The low R_{ON} reduces the negative effect a series resistance has on the quality factor of the shunt inductor. The large bandwidth enables higher frequency band-pass filters.

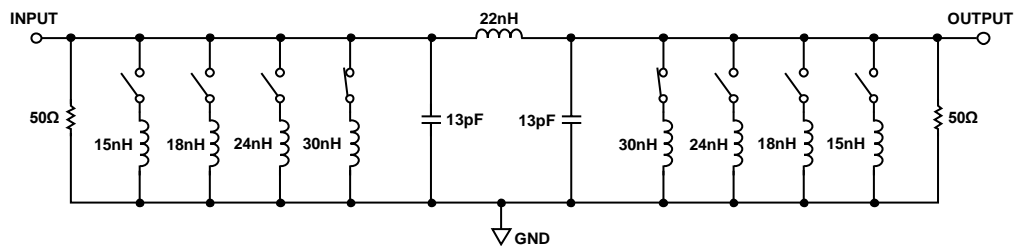

Figure 54. Reconfigurable Band-Pass Filter Achieved Using Two ADGM1004 MEMS Switches

HANDLING GUIDELINES

ELECTRICAL OVERSTRESS (EOS) PRECAUTIONS

A stored charge inadvertently conducted through the switches can result in immediate permanent damage to the ADGM1004. Therefore, observe the following precautions:

- Treat the ADGM1004 as a static sensitive device and observe all normal handling precautions, which include working only on static dissipative surfaces, wearing wrist straps or other ESD control devices, and storing unused devices in conductive foam.
- Avoid connecting large capacitive terminations directly to the switch. A shunt capacitor can store a charge that can potentially give rise to hot switching events when the switch opens or closes, affecting the lifetime of the switch. Figure 55 shows where to avoid large capacitive terminations.

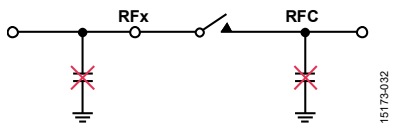

Figure 55. Avoid Connecting Large Capacitive Terminations Directly to the Switch

DC VOLTAGE RANGE

The dc voltage range of the switch, the dc signal range the switch is specified to carry, is ± 6 V (see Table 1).

VOLTAGE STANDOFF LIMIT

The standoff voltage is the highest voltage that can be applied to the RFC drain electrode of the switch without adversely affecting the performance or reliability of the switch. The standoff voltage limit of the RFX pin to RFC pin is 20 V. Refer to the Absolute Maximum Ratings section (Table 2) for more details.

MECHANICAL SHOCK PRECAUTIONS

The device passes an extensive mechanical shock qualification process. Table 6 shows a summary of the mechanical shock qualification tests used on the ADGM1004. These tests validate the robustness of the device to mechanical shocks.

Table 6. Mechanical Shock Qualification Summary

Parameter	Qualification
Random Drop	AEC-Q100 Test G5, five drops from 0.6 m
Vibration Testing	MIL-STD-883, M2007.3, Condition B, 20 Hz to 2000 Hz at 50 g
Group D Sub 4 MIL-STD-883, M5005	Mechanical shock, 1500 g, 0.5 ms, vibration 50 g sine sweep, 20 Hz to 2000 Hz, acceleration 30,000 g

The device must be handled with care. As is the case with electromechanical relays, do not use the device if dropped and ensure that there are minimal mechanical shocks during the handling and manufacturing of the device.

Figure 56 shows examples of loose device handling situations that must be avoided due to mechanical shock and ESD event risk.

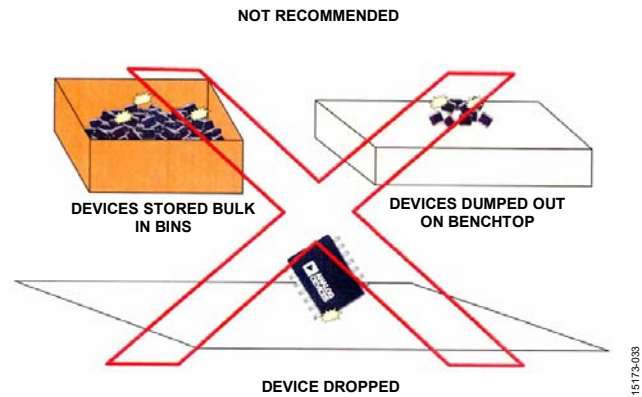
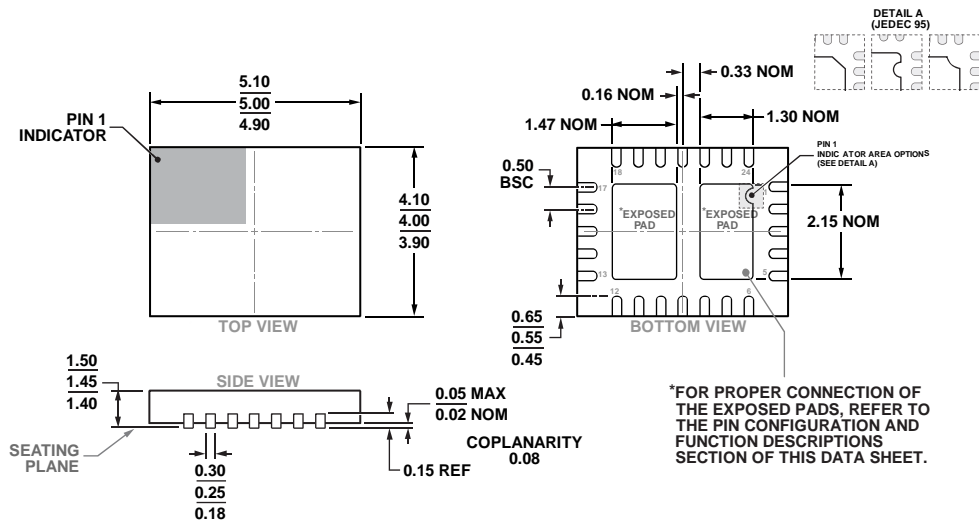

Figure 56. Device Handling Precautions

OUTLINE DIMENSIONS



ORDERING GUIDE

Model ¹	Temperature Range	Package Description	Package Option
ADGM1004JCPZ-R2	0°C to 85°C	24-Lead Lead Frame Chip Scale Package [LFCSP]	CP-24-4
ADGM1004JCPZ-RL7	0°C to 85°C	24-Lead Lead Frame Chip Scale Package [LFCSP]	CP-24-4
EVAL-ADGM1004EBZ		Evaluation Board	

¹ Z = RoHS Compliant Part.