

Description

The **SiT5359** is a ±50 ppb precision MEMS Super-TCXO that is engineered for best dynamic performance. It is ideal for high reliability telecom, wireless and networking, industrial, precision GNSS and audio/video applications.

Leveraging SiTime’s unique DualMEMS™ temperature sensing and TurboCompensation™ technologies, the SiT5359 delivers the best dynamic performance for timing stability in the presence of environmental stressors due to air flow, temperature perturbation, vibration, shock, and electromagnetic interference. This device also integrates multiple on-chip regulators to filter power supply noise, eliminating the need for a dedicated external LDO.

The SiT5359 offers three device configurations that can be ordered using [Ordering Codes](#) for:

- 1) TCXO with non-pullable output frequency,
- 2) VCTCXO allowing voltage control of output frequency, and
- 3) DCTCXO, enabling digital control of output frequency using an I²C interface, pullable to 5 ppt (parts per trillion) resolution.

The SiT5359 can be factory programmed for any combination of frequency, stability, voltage, and pull range. Programmability enables designers to optimize clock configurations while eliminating long lead times and customization costs associated with quartz devices where each frequency is custom built.

Refer to [Manufacturing Guideline](#) for proper reflow profile and PCB cleaning recommendations to ensure best performance.

Features

- Output 60–189 MHz, and 200–220 MHz, in 1 Hz steps
- Factory programmable options for low lead time
- Best dynamic stability under airflow, thermal shock
 - ±50 ppb stability across temperature
 - ±1 ppb/°C typical frequency slope (ΔF/ΔT)
 - 3e-11 ADEV at 10 second averaging time
- 0°C to +70°C operating temperature
- No activity dips or micro jumps
- Resistant to shock, vibration and board bending
- On-chip regulators eliminate the need for external LDOs
- Digital frequency pulling (DCTCXO) via I²C
 - Digital control of output frequency and pull range
 - Up to ±3200 ppm pull range
 - Frequency pull resolution down to 5 ppt
- 2.5V, 2.8V, 3.0V and 3.3V supply voltage
- LVCMOS output
- RoHS and REACH compliant
- Pb-free, Halogen-free, Antimony-free

Applications

- 4G/5G radio, Small cell
- IEEE1588 boundary and grandmaster clocks
- Carrier-grade routers and switches
- Synchronous Ethernet
- Optical transport – SONET/SDH, OTN, Stratum 3
- DOCSIS 3.x remote PHY
- GPS disciplined oscillators
- Precision GNSS systems
- Test and measurement



Block Diagram

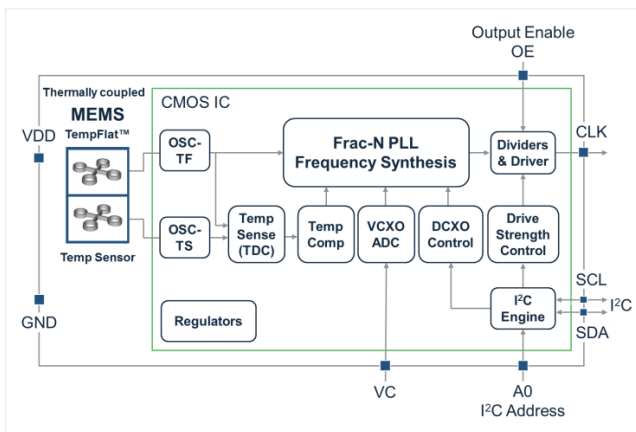

Figure 1. SiT5359 Block Diagram

5.0 x 3.2 mm² Package Pinout

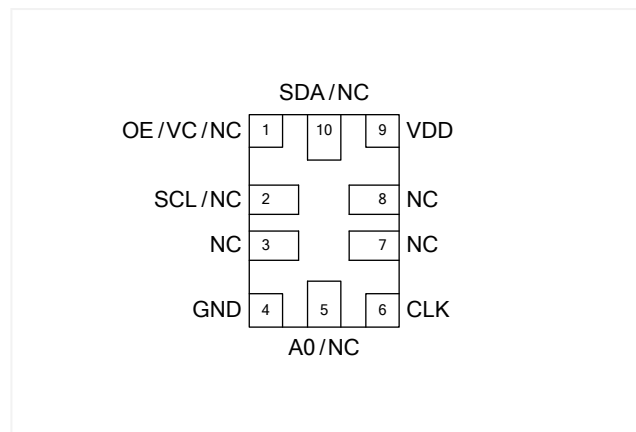
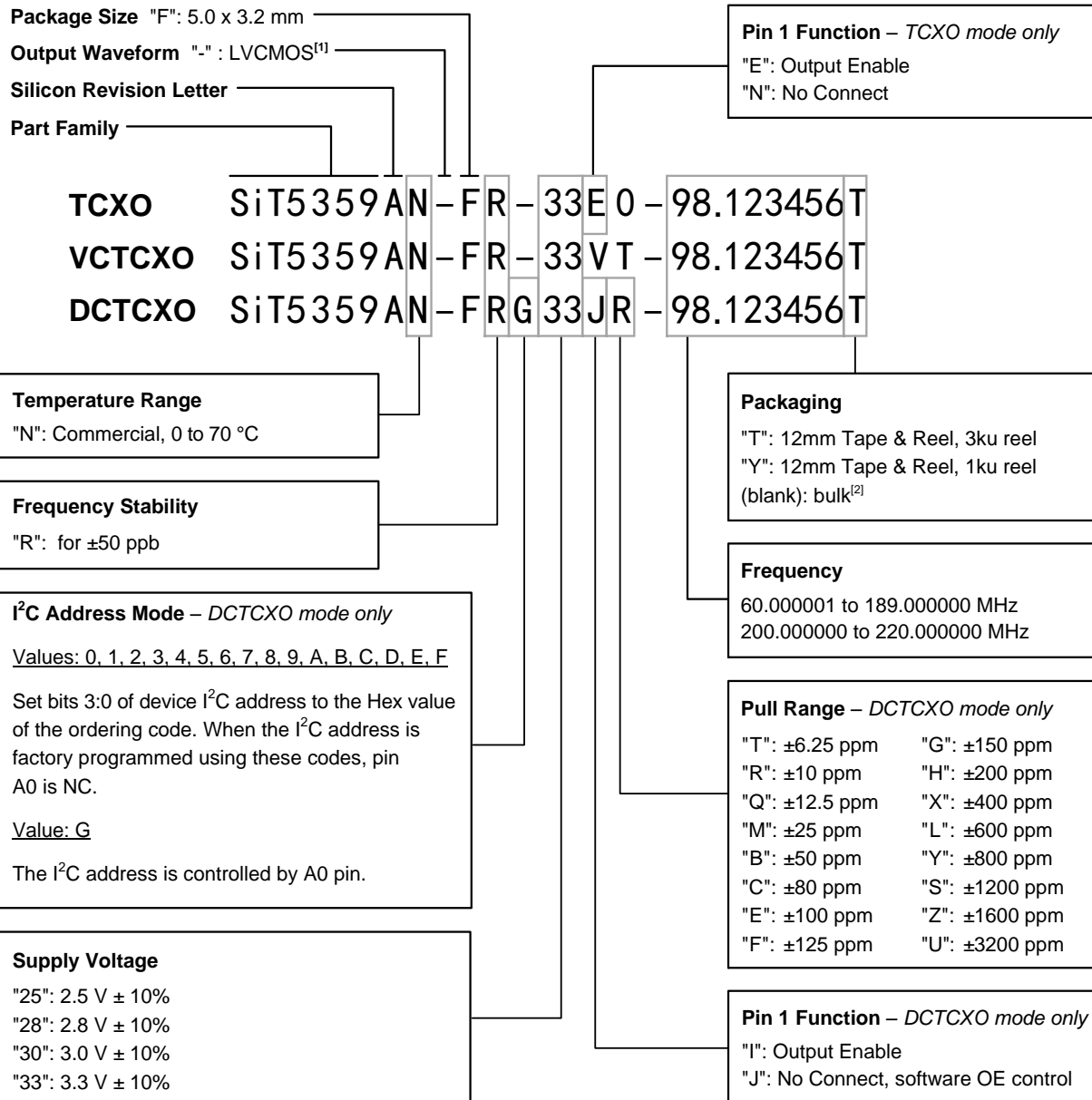

Figure 2. Pin Assignments (Top view)
(Refer to [Table 10](#) for Pin Descriptions)

Ordering Information

The following part number guide is for reference only. To customize and build an exact part number, use the SiTime [Part Number Generator](#). To validate the part number, use the SiTime [Part Number Decoder](#).



Notes:

- "-" corresponds to the default rise/fall time for LVCMOS output as specified in [Table 1](#) (Electrical Characteristics). Contact SiTime for other rise/fall time options for best EMI.
- Bulk is available for sampling only.

TABLE OF CONTENTS

Description 1

Features..... 1

Applications 1

Block Diagram 1

5.0 x 3.2 mm² Package Pinout..... 1

Ordering Information 2

Electrical Characteristics..... 4

Device Configurations and Pin-outs..... 8

 Pin-out Top Views..... 8

Test Circuit Diagrams for LVCMOS Outputs..... 9

Waveforms..... 10

Timing Diagrams..... 10

Typical Performance Plots 11

Architecture Overview..... 14

 Frequency Stability 14

 Output Frequency and Format..... 14

 Output Frequency Tuning 14

 Pin 1 Configuration (OE, VC, or NC) 15

Device Configurations..... 15

 TCXO Configuration 15

 VCTCXO Configuration 16

 DCTCXO Configuration 17

VCXO-Specific Design Considerations 18

 Linearity 18

 Control Voltage Bandwidth 18

 FV Characteristic Slope K_v 18

 Pull Range, Absolute Pull Range..... 19

DCTCXO-Specific Design Considerations 20

 Pull Range and Absolute Pull Range..... 20

 Output Frequency 21

 I²C Control Registers 23

 Register Descriptions..... 23

 Register Address: 0x00. Digital Frequency Control Least Significant Word (LSW) 23

 Register Address: 0x01. OE Control, Digital Frequency Control Most Significant Word (MSW)..... 24

 Register Address: 0x02. DIGITAL PULL RANGE CONTROL^[14] 25

 Serial Interface Configuration Description 26

 Serial Signal Format 26

 Parallel Signal Format 27

 Parallel Data Format..... 27

 I²C Timing Specification..... 29

 I²C Device Address Modes 30

 Schematic Example 31

Dimensions and Patterns..... 32

Layout Guidelines 33

Manufacturing Guidelines 33

Electrical Characteristics

All Min and Max limits are specified over temperature and rated operating voltage with 15 pF output load unless otherwise stated. Typical values are at 25°C and 3.3V V_{dd}.

Table 1. Output Characteristics

Parameters	Symbol	Min.	Typ.	Max.	Unit	Condition
Frequency Coverage						
Nominal Output Frequency Range	F _{nom}	60.000001	–	189	MHz	
		200	–	220	MHz	
Temperature Range						
Operating Temperature Range	T _{use}	0	–	+70	°C	Commercial, ambient temperature
Frequency Stability						
Initial Tolerance	F _{init}	-0.5	–	+0.5	ppm	Initial frequency at 25°C inclusive of solder-down shift at 48 hours after 2 reflows
Supply Voltage Sensitivity	F _{Vdd}	-2.5	±0.5	+2.5	ppb	V _{dd} ±5%
Output Load Sensitivity	F _{load}	-0.4	±0.05	+0.4	ppb	15 pF ±10%
Frequency Stability over Temperature	F _{stab}	-50	–	+50	ppb	Referenced to (max frequency + min frequency)/2 over the rated temperature range. V _c =V _{dd} /2 for VCTCXO
Frequency vs. Temperature Slope	ΔF/ΔT	-2	±0.9	+2	ppb/°C	0 to 70 °C
Dynamic Frequency Change during Temperature Ramp	F _{dynamic}	-0.02	±0.008	+0.02	ppb/s	0.5°C/min temperature ramp rate, -20 to 85 °C
24-hour holdover Stability	F _{24_Hold}	-0.15	–	+0.15	ppm	Inclusive of over-temperature frequency variation
Hysteresis Over Temperature	F _{hys}	–	±10	–	ppb	0 to 70 °C, 0.5°C/min ramp rate
One-Day Aging	F _{1d}	–	±1	–	ppb	At 25°C, after 30-days of continued operation. Aging is measured with respect to day 31.
One-Year Aging	F _{1y}	–	±0.3	–	ppm	At 25°C, after 2-days of continued operation. Aging is measured with respect to day 3.
20-Year Aging	F _{20y}	–	±0.5	–	ppm	
LVC MOS Output Characteristics						
Duty Cycle	DC	45	–	55	%	60 to 150 MHz
		42	–	55	%	150 to 189 MHz, 200 to 220 MHz
Rise/Fall Time	Tr, Tf	0.8	1.2	1.9	ns	10% - 90% V _{dd}
Output Voltage High	VOH	90%	–	–	V _{dd}	IOH = +3mA
Output Voltage Low	VOL	–	–	10%	V _{dd}	IOL = -3mA
Start-up Characteristics						
Start-up Time	T _{start}	–	2.5	3.5	ms	Time to first pulse, measured from the time V _{dd} reaches 90% of its final value. V _{dd} ramp time = 100 μs from 0V to V _{dd}
Output Enable Time	T _{oe}	–	–	285	ns	See Timing Diagrams section below.
First Pulse Accuracy	T _{stability}	–	5	45	ms	Time to first accurate pulse within rated stability, measured from the time V _{dd} reaches 90% of its final value. V _{dd} ramp time = 100 μs

Table 2. DC Characteristics

Parameters	Symbol	Min.	Typ.	Max.	Unit	Condition
Supply Voltage						
Supply Voltage	V _{dd}	2.25	2.5	2.75	V	Contact SiTime for 2.25V to 3.63V continuous supply voltage support.
		2.52	2.8	3.08	V	
		2.7	3.0	3.3	V	
		2.97	3.3	3.63	V	
Current Consumption						
Current Consumption	I _{dd}	–	48	62	mA	F _{nom} = 100 MHz, No Load, TCXO and DCTCXO modes
		–	52	66	mA	F _{nom} = 100 MHz, No Load, VCTCXO mode
OE Disable Current	I _{od}	–	45	52	mA	OE = GND, output weakly pulled down. TCXO, DCTCXO
		–	49	56	mA	OE = GND, output weakly pulled down. VCTCXO mode

Table 3. Input Characteristics

Parameters	Symbol	Min.	Typ.	Max.	Unit	Condition
Input Characteristics – OE Pin						
Input Impedance	Z _{in}	75	–	–	kΩ	Internal pull up to V _{dd}
Input High Voltage	V _{IH}	70%	–	–	V _{dd}	
Input Low Voltage	V _{IL}	–	–	30%	V _{dd}	
Frequency Tuning Range – Voltage Control or I²C mode						
Pull Range	PR	±6.25	–	–	ppm	VCTCXO mode. Contact SiTime for ±12.5 and ±25 ppm.
		±6.25	–	–	ppm	DCTCXO mode
		±10				
		±12.5				
		±25				
		±50				
		±80				
		±100				
		±125				
		±150				
		±200				
		±400				
±600						
±800						
±1200						
±1600						
±3200						
Absolute Pull Range ^[3]	APR	±5.2	–	–	ppm	DCTCXO, VCTCXO for PR = ±6.25 ppm
Upper Control Voltage	VC _U	90%	–	–	V _{dd}	VCTCXO mode
Lower Control Voltage	VC _L	–	–	10%	V _{dd}	VCTCXO mode
Control Voltage Input Impedance	VC _z	8	–	–	MΩ	VCTCXO mode
Control Voltage Input Bandwidth	VC _{bw}	–	10	–	kHz	VCTCXO mode. Contact SiTime for other bandwidth options.
Frequency Control Polarity	F _{pol}	Positive				VCTCXO mode
Pull Range Linearity	PR _{lin}	–	0.5	1.0	%	VCTCXO mode
I²C Interface Characteristics, 200 Ohm, 550 pF (Max I²C Bus Load)						
Bus Frequency	F _{I2C}	–	100	–	kHz	-40 to 105 °C
		–	400	–	kHz	-40 to 105 °C
		–	1000	–	kHz	-40 to 85 °C
Input Voltage Low	V _{IL_I2C}	–	–	30%	V _{dd}	DCTCXO mode
Input Voltage High	V _{IH_I2C}	70%	–	–	V _{dd}	DCTCXO mode
Output Voltage Low	V _{OL_I2C}	–	–	0.4	V	DCTCXO mode
Input Leakage current	I _L	0.5	–	24	μA	0.1 V _{DD} < V _{OUT} < 0.9 V _{DD} . Includes typical leakage current from 200 kΩ pull resistor to V _{DD} . DCTCXO mode
Input Capacitance	C _{IN}	–	–	5	pF	DCTCXO mode

Note:

3. APR = PR – initial tolerance – 20-year aging – frequency stability over temperature. Refer to [Table 13](#) for APR with respect to other pull range options.

Table 4. Jitter & Phase Noise

Parameters	Symbol	Min.	Typ.	Max.	Unit	Condition
Jitter						
RMS Phase Jitter (random)	T_phj	–	0.31	0.48	ps	F_nom = 100 MHz, Integration bandwidth = 12 kHz to 20 MHz
RMS Period Jitter	T_jitt_per	–	1.0	1.8	ps	F_nom = 100 MHz, population 10k
Peak Cycle-to-Cycle Jitter	T_jitt_cc	–	6.6	13.4	ps	F_nom = 100 MHz, population 1k, measured as absolute value
Phase Noise						
1 Hz offset		–	-61	-54	dBc/Hz	F_nom = 100 MHz TCXO and DCTCXO modes, and VCTCXO mode with ±6.25 ppm pull range
10 Hz offset		–	-89	-83	dBc/Hz	
100 Hz offset		–	-107	-103	dBc/Hz	
1 kHz offset		–	-128	-124	dBc/Hz	
10 kHz offset		–	-133	-131	dBc/Hz	
100 kHz offset		–	-133	-130	dBc/Hz	
1 MHz offset		–	-150	-146	dBc/Hz	
5 MHz offset		–	-157	-151	dBc/Hz	
10 MHz offset		–	-157	-152	dBc/Hz	
20 MHz offset		–	-159	-152	dBc/Hz	
Spurious	T_spur	–	-91	-86	dBc	F_nom = 100 MHz, 1 kHz to 40 MHz offsets

Table 5. Absolute Maximum Limits

Attempted operation outside the absolute maximum ratings may cause permanent damage to the part. Actual performance of the IC is only guaranteed within the operational specifications, not at absolute maximum ratings.

Parameter	Test Conditions	Value	Unit
Storage Temperature		-65 to 125	°C
Continuous Power Supply Voltage Range (Vdd)		-0.5 to 4	V
Human Body Model (HBM) ESD Protection	JESD22-A114	2000	V
Soldering Temperature (follow standard Pb-free soldering guidelines)		260	°C
Junction Temperature ^[4]		130	°C

Note:

4. Exceeding this temperature for an extended period of time may damage the device.

Table 6. Thermal Considerations^[5]

Package	θ_{JA} (°C/W)	$\theta_{JC, Bottom}$ (°C/W)
Ceramic 5.0 x 3.2 mm ²	54	15

Note:

5. Measured in still air.

Table 7. Maximum Operating Junction Temperature^[6]

Max Operating Temperature (ambient)	Maximum Operating Junction Temperature
70°C	80°C

Note:

6. Datasheet specifications are not guaranteed if junction temperature exceeds the maximum operating junction temperature.

Table 8. Environmental Compliance

Parameter	Test Conditions	Value	Unit
Mechanical Shock Resistance	MIL-STD-883F, Method 2002	10000	g
Mechanical Vibration Resistance	MIL-STD-883F, Method 2007	70	g
Temperature Cycle	JESD22, Method A104	–	–
Solderability	MIL-STD-883F, Method 2003	–	–
Moisture Sensitivity Level	MSL1 @260°C	–	–

Device Configurations and Pin-outs

Table 9. Device Configurations

Configuration	Pin 1	Pin 5	I ² C Programmable Parameters
TCXO	OE/NC	NC	–
VCTCXO	VC	NC	–
DCTCXO	OE/NC	A0/NC	Frequency Pull Range, Frequency Pull Value, Output Enable control.

Pin-out Top Views

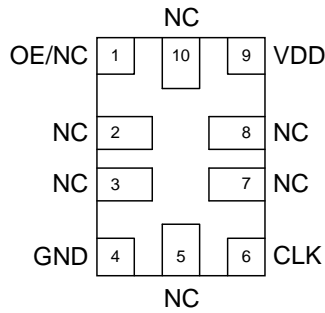

Figure 3. TCXO

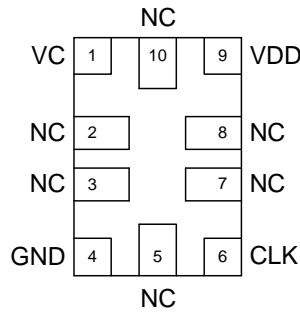

Figure 4. VCTCXO

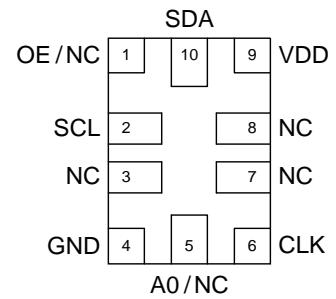

Figure 5. DCTCXO

Table 10. Pin Description

Pin	Symbol	I/O	Internal Pull-up/Pull Down Resistor	Function
1	OE/NC/VC	OE – Input	100 kΩ Pull-Up	H ^[7] : specified frequency output L: output is high impedance. Only output driver is disabled.
		NC ^[8] – No Connect	–	H or L or Open: No effect on output frequency or other device functions
		VC – Input	–	Control Voltage in VCTCXO Mode
2	SCL / NC ^[8]	SCL – Input	200 kΩ Pull-Up	I ² C serial clock input.
		No Connect	–	H or L or Open: No effect on output frequency or other device functions
3	NC ^[8]	No Connect	–	H or L or Open: No effect on output frequency or other device functions
4	GND	Power	–	Connect to ground
5	A0 / NC ^[8]	A0 – Input	100 kΩ Pull-Up	Device I ² C address when the address selection mode is via the A0 pin. This pin is NC when the I ² C device address is specified in the ordering code. <u>A0 Logic Level</u> <u>I²C Address</u> 0 1100010 1 1101010
		NC – No Connect	–	H or L or Open: No effect on output frequency or other device functions.
6	CLK	Output	–	LVC MOS
7	NC ^[8]	No Connect	–	H or L or Open: No effect on output frequency or other device functions
8	NC ^[8]	No Connect	–	H or L or Open: No effect on output frequency or other device functions
9	VDD	Power	–	Connect to VDD ^[8]
10	SDA / NC ^[8]	SDA – Input/Output	200 kΩ Pull Up	I ² C Serial Data.
		NC – No Connect	–	H or L or Open: No effect on output frequency or other device functions.

Notes:

- In OE mode for noisy environments, a pull-up resistor of 10 kΩ or less is recommended if pin 1 is not externally driven. If pin 1 needs to be left floating, use the NC option.
- A 0.1 μF capacitor in parallel with a 10 μF capacitor are required between Vdd and GND. The 0.1 μF capacitor is recommended to place close to the device, and place the 10 μF capacitor less than 2 inches away.
- All NC pins can be left floating and do not need to be soldered down.

Test Circuit Diagrams for LVCMOS Outputs

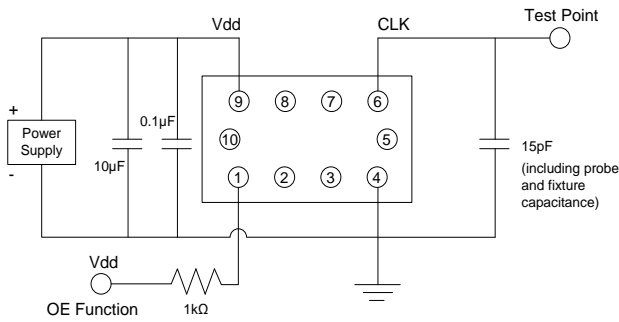

Figure 6. LVCMOS Test Circuit (OE Function)

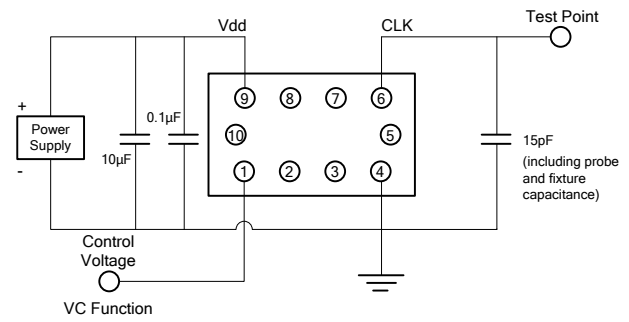

Figure 7. LVCMOS Test Circuit (VC Function)

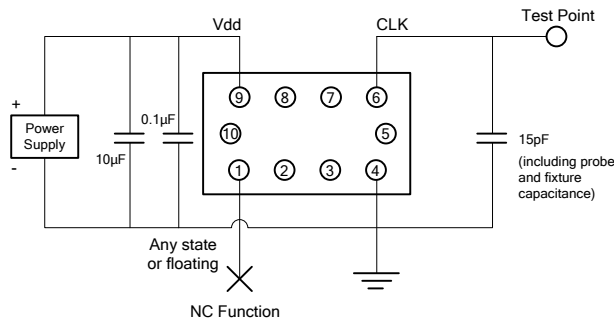

Figure 8. LVCMOS Test Circuit (NC Function)

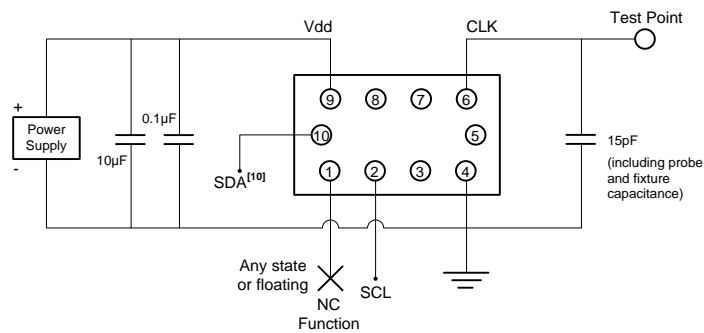

Figure 9. LVCMOS Test Circuit (I²C Control), DCTCXO mode

Note:

10. SDA is open-drain and may require pull-up resistor if not present in I²C test setup.

Waveforms

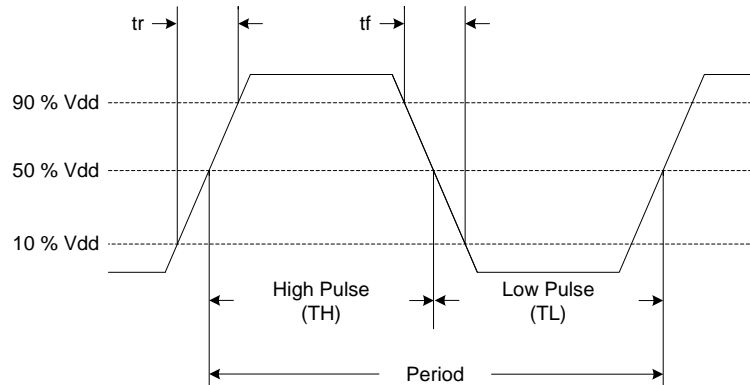
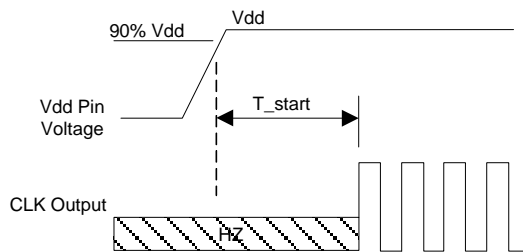

Figure 10. LVCMOS Waveform Diagram^[11]

Note:

11. Duty Cycle is computed as $Duty\ Cycle = TH/Period$.

Timing Diagrams



T_{start} : Time to start from power-off

Figure 11. Startup Timing

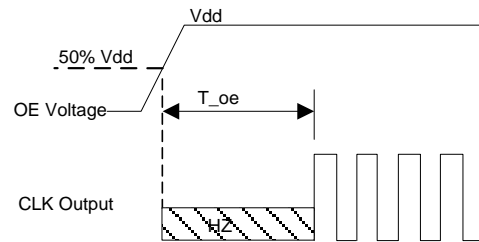

T_{oe} : Time to re-enable the clock output

Figure 12. OE Enable Timing (OE Mode Only)

Typical Performance Plots

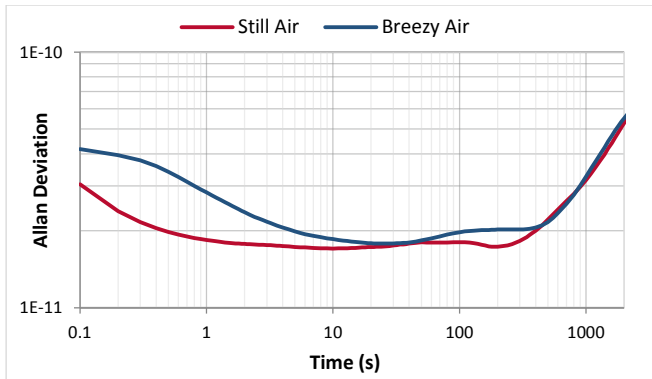

Figure 13. ADEV

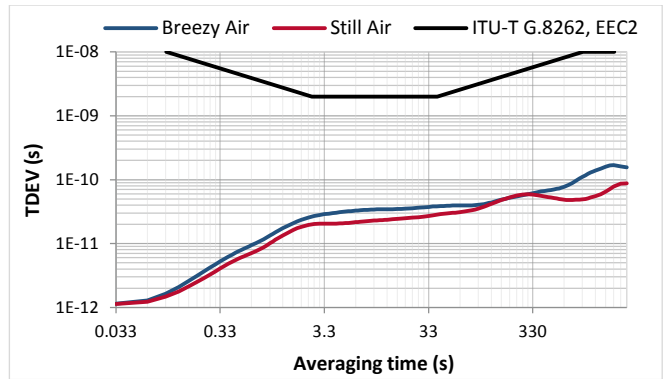

Figure 14. TDEV (0.1 Hz loop bandwidth)

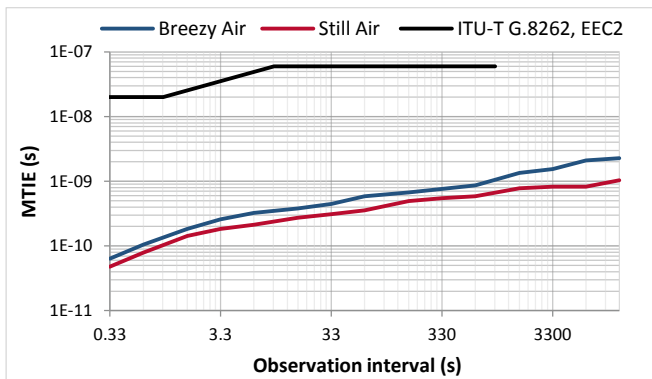

Figure 15. MTIE (0.1 Hz loop bandwidth)

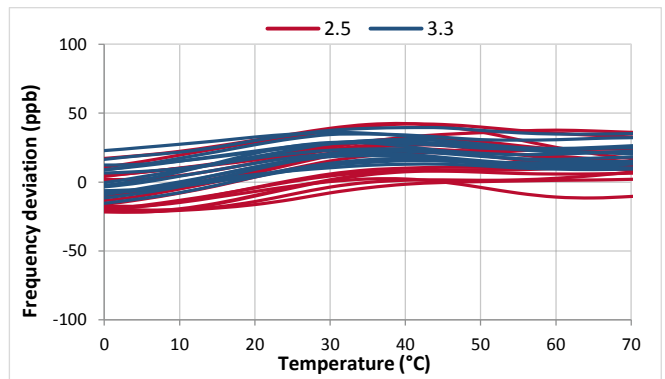

Figure 16. Frequency vs Temperature

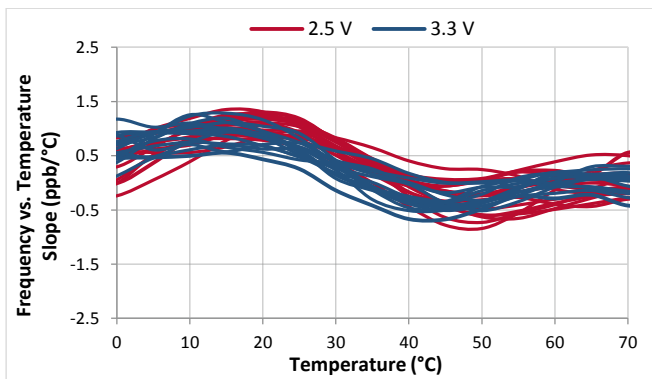

Figure 17. Freq. vs. Temp. Slope ($\Delta F/\Delta T$)

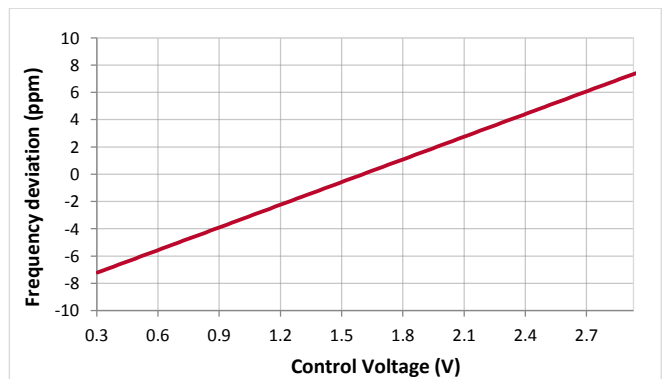

Figure 18. VCTCXO frequency pull characteristic

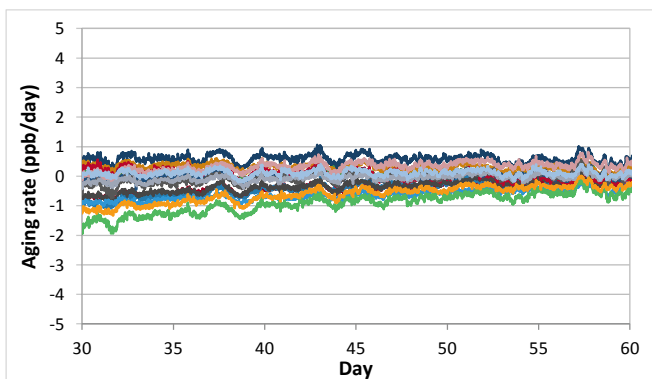

Figure 19. 1-day aging rate (to 62 days)

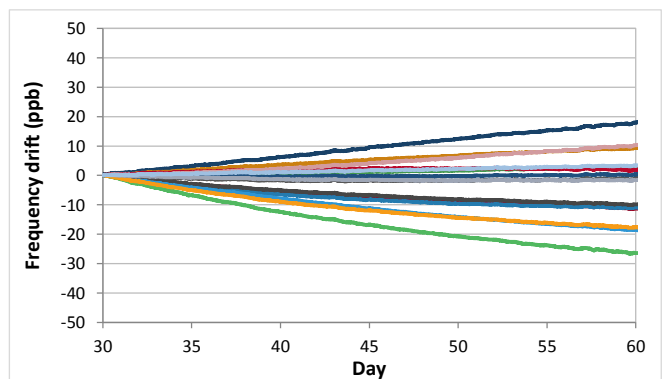

Figure 20. Drift over 30 days relative to the first reading

Typical Performance Plots (continued)

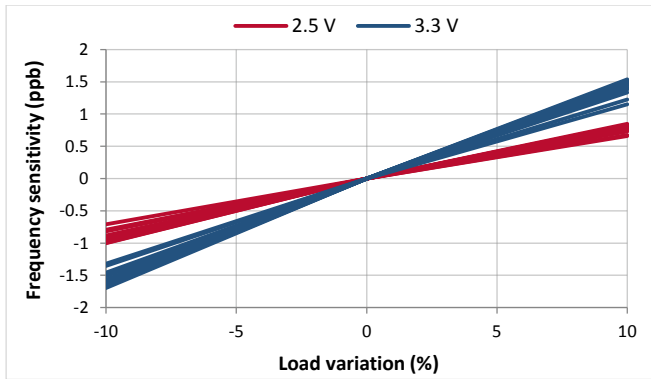

Figure 21. Load sensitivity

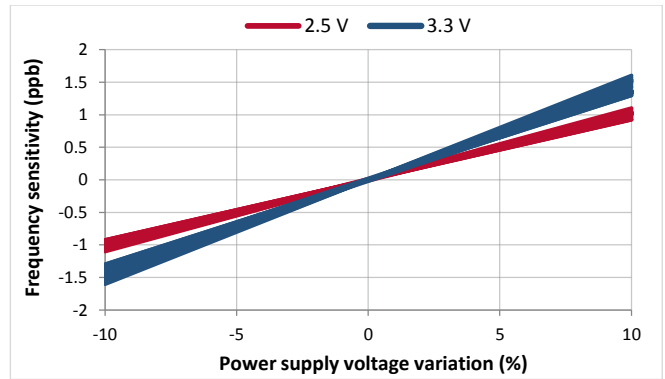

Figure 22. VDD sensitivity

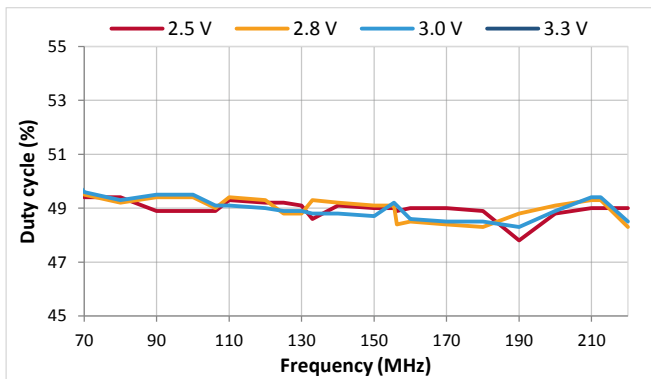

Figure 23. Duty Cycle (LVCMOS)

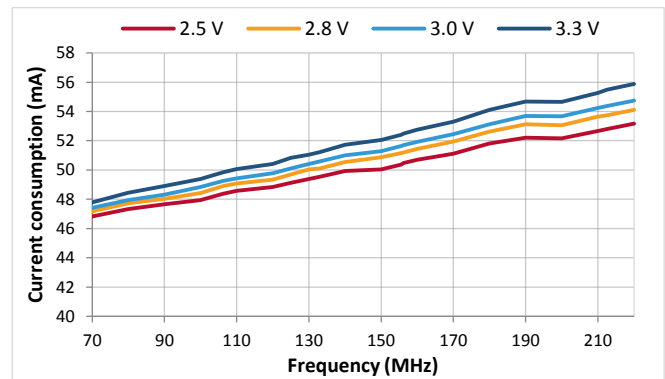

Figure 24. IDD DCTCXO (LVCMOS)

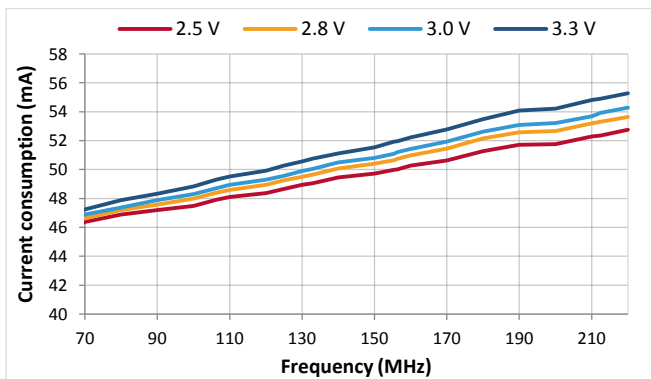

Figure 25. IDD TCXO (LVCMOS)

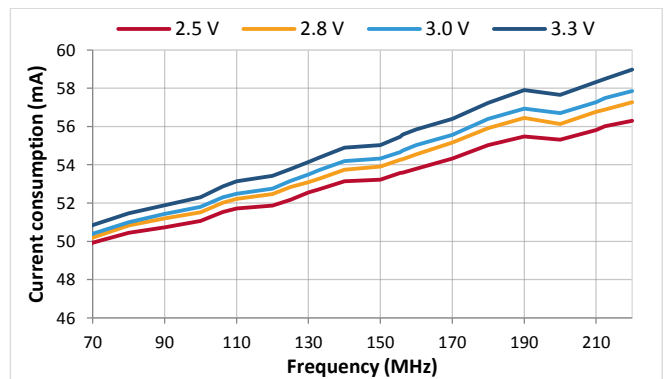

Figure 26. IDD VCTCXO (LVCMOS)

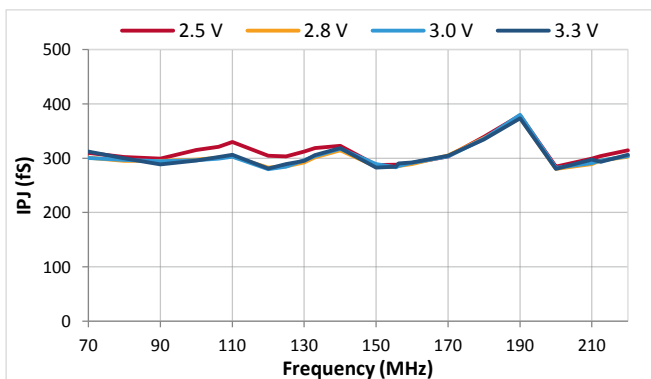

Figure 27. T_{phj}, RMS Random, (DC)TCXO (LVCMOS)

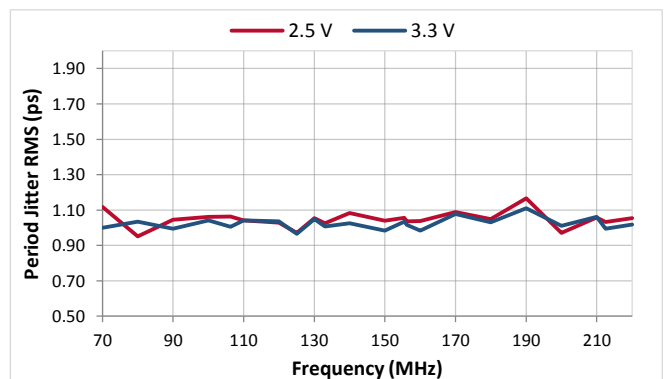

Figure 28. Period Jitter, RMS (LVCMOS)

Typical Performance Plots (continued)

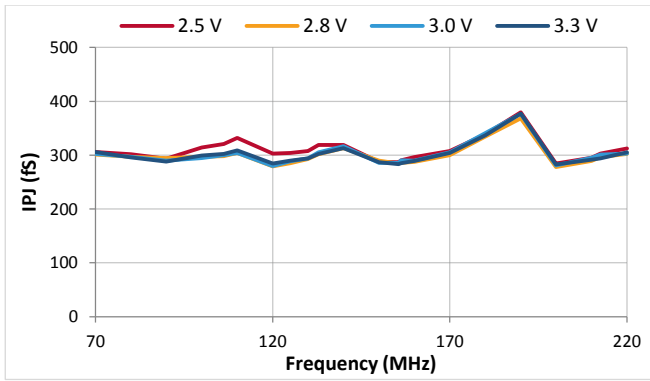

Figure 29. T_{phj}, RMS Random, VCTCXO (LVC MOS)

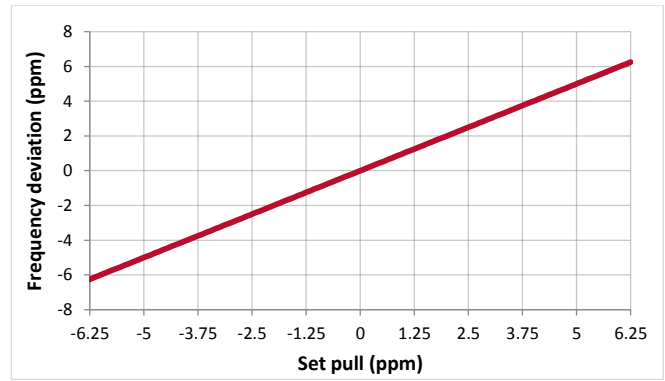

Figure 30. DCTCXO frequency pull characteristic

Architecture Overview

Based on SiTime’s innovative Elite Platform™, the SiT5359 delivers exceptional dynamic performance, i.e. resilience to environmental stressors such as shock, vibration, and fast temperature transients. Underpinning the Elite platform are SiTime’s unique DualMEMS™ temperature sensing architecture and TurboCompensation™ technologies.

DualMEMS is a noiseless temperature compensation scheme. It consists of two MEMS resonators fabricated on the same die substrate. The TempFlat™ resonator is designed with a flat frequency characteristic over temperature whereas the temperature sensing resonator is by design sensitive to temperature changes. The ratio of frequencies between these two resonators provides an accurate reading of the resonator temperature with 20 µK resolution.

By placing the two MEMS resonators on the same die, this temperature sensing scheme eliminates any thermal lag and gradients between resonator and temperature sensor, thereby overcoming an inherent weakness of legacy quartz TCXOs.

The DualMEMS temperature sensor drives a state-of-the-art CMOS temperature compensation circuit. The TurboCompensation design, with >100 Hz compensation bandwidth, achieves a dynamic frequency stability that is far superior to any quartz TCXO. The digital temperature compensation enables additional optimization of frequency stability and frequency slope over temperature within any chosen temperature range for a given system design.

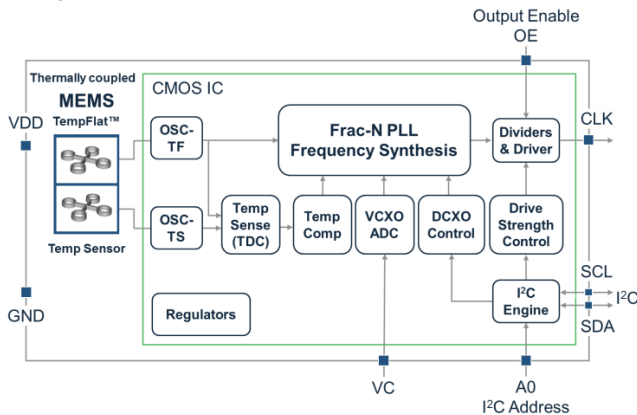

Figure 31. Elite Architecture

The Elite platform also incorporates a high resolution, low noise frequency synthesizer along with the industry standard I²C bus. This unique combination enables system designers to digitally control the output frequency in steps as low as 5 ppt and over a wide range up to ±3200 ppm.

For more information regarding the Elite platform and its benefits please visit:

- [SiTime's breakthroughs](#) section
- TechPaper: [DualMEMS Temperature Sensing Technology](#)
- TechPaper: [DualMEMS Resonator TDC](#)

Functional Overview

The SiT5359 is designed for maximum flexibility with an array of factory programmable options, enabling system designers to configure this precision device for optimal performance in a given application.

Frequency Stability

The SiT5359 comes in one factory-trimmed stability grade.

Table 11. Stability Grades vs. Ordering Codes

Frequency Stability Over Temperature	Ordering Code
±50 ppb	R

Output Frequency and Format

The SiT5359 can be factory programmed for an output frequency without sacrificing lead time or incurring an upfront customization cost typically associated with custom-frequency quartz TCXOs.

Output Frequency Tuning

In addition to the non-pullable TCXO, the SiT5359 can also support output frequency tuning through either an analog control voltage (VCTCXO), or I²C interface (DCTCXO). The I²C interface enables 16 factory programmed pull-range options from ±6.25 ppm to ±3200 ppm. The pull range can also be reprogrammed via I²C to any supported pull-range value.

Refer to [Device Configuration](#) section for details.

Pin 1 Configuration (OE, VC, or NC)

Pin 1 of the SiT5359 can be factory programmed to support three modes: Output Enable (OE), Voltage Control (VC), or No Connect (NC).

Table 12. Pin Configuration Options

Pin 1 Configuration	Operating Mode	Output
OE	TCXO/DCTCXO	Active or High-Z
NC	TCXO/DCTCXO	Active
VC	VCTCXO	Active

When pin 1 is configured as OE pin, the device output is guaranteed to operate in one of the following two states:

- Clock output with the frequency specified in the part number when Pin 1 is pulled to logic high
- Hi-Z mode with weak pull down when pin 1 is pulled to logic low.

When pin 1 is configured as NC, the device is guaranteed to output the frequency specified in the part number at all times, regardless of the logic level on pin 1.

In the VCTCXO configuration, the user can fine-tune the output frequency from the nominal frequency specified in the part number by varying the pin 1 voltage. The guaranteed allowable variation of the output frequency is specified as pull range. A VCTCXO part number must contain a valid pull-range ordering code.

Device Configurations

The SiT5359 supports 3 device configurations – TCXO, VCTCXO, and DCTCXO. The TCXO and VCTCXO options are directly compatible with the quartz TCXO and VCTCXO. The DCTCXO configuration provides performance enhancement by eliminating VCTCXO’s sensitivity to control voltage noise with an I²C digital interface for frequency tuning.

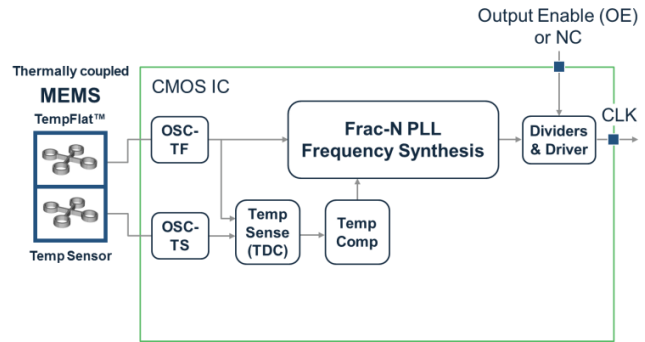

Figure 32. Block Diagram – TCXO

TCXO Configuration

The TCXO configuration generates a fixed frequency output, as shown in Figure 32. The frequency is specified by the user in the frequency field of the device ordering code and then factory programmed. Other factory programmable options include supply voltage, and pin 1 functionality (OE or NC).

Refer to the [Ordering Information](#) section at the end of the datasheet for a list of all ordering options.

VCTCXO Configuration

A VCTCXO, shown in [Figure 33](#), is a frequency control device whose output frequency is an approximately linear function of control voltage applied to the voltage control pin. VCTCXOs have a number of use cases including the VCO portion of a jitter attenuation/jitter cleaner PLL Loop.

The SiT5359 achieves a 10x better pull range linearity of <0.5% via a high-resolution fractional PLL compared with 5% to 10% typical of quartz VCTCXOs that rely on pulling a resonator. By contrast, quartz-based VCTCXOs change output frequency by varying the capacitive load of a crystal resonator using varactor diodes, which results in poor linearity.

Note that the output frequency of the VCTCXO is proportional to the analog control voltage applied to pin 1. Because this control signal is analog and directly controls the output frequency, care must be taken to minimize noise on this pin.

The nominal output frequency is factory programmed per the customer's request to 6 digits of precision and is defined as the output frequency when the control voltage equals $V_{dd}/2$. The maximum output frequency variation from this nominal value is set by the pull range, which is also factory programmed to the customer's desired value and specified by the ordering code. The [Ordering Information](#) section shows all ordering options and associated ordering codes.

Refer to Appendix 1 [Design Considerations with VCTCXO](#) for more information on critical VCTCXO parameters including pull range linearity, absolute pull range, control voltage bandwidth, and K_v .

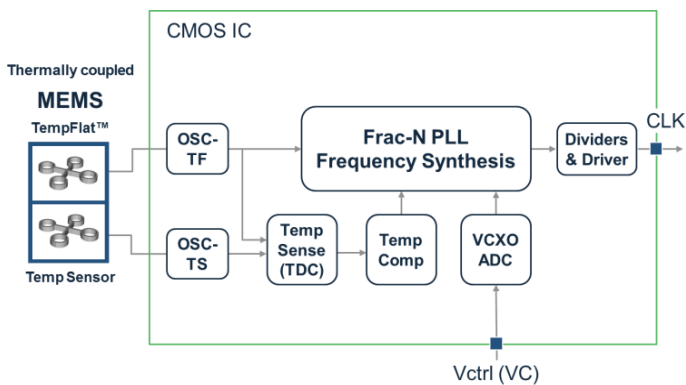

Figure 33. Block Diagram – VCTCXO

VCXO-Specific Design Considerations

Linearity

In any VCTCXO, there will be some deviation of the frequency-voltage (FV) characteristic from an ideal straight line. Linearity is the ratio of this maximum deviation to the total pull range, expressed as a percentage. Figure 35 below shows the typical pull linearity of a SiTime VCTCXO. The linearity is excellent (1% maximum) relative to most quartz offerings because the frequency pulling is achieved with a PLL rather than varactor diodes.

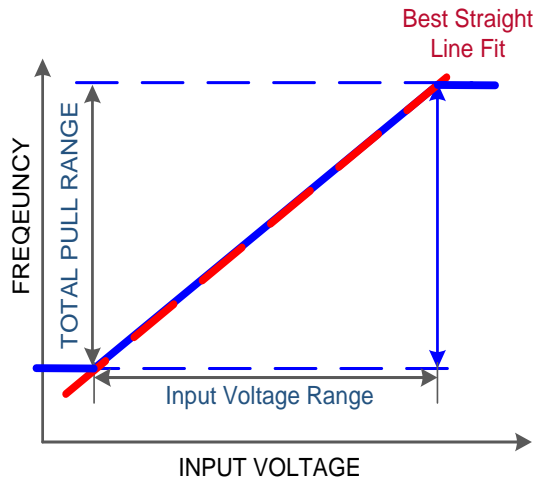

Figure 35. Typical SiTime VCTCXO Linearity

Control Voltage Bandwidth

Control voltage bandwidth, sometimes called “modulation rate” or “modulation bandwidth”, indicates how fast a VCO can respond to voltage changes at its input. The ratio of the output frequency variation to the input voltage variation, previously denoted by K_V , has a low-pass characteristic in most VCTCXOs. The control voltage bandwidth equals the modulating frequency where the output frequency deviation equals 0.707 (e.g. -3 dB) of its DC value, for DC inputs swept in the same voltage range.

For example, a part with a ±6.25 ppm pull range and a 0-3V control voltage can be regarded as having an average K_V of 4.17 ppm/V ($12.5 \text{ ppm}/3\text{V} = 4.17 \text{ ppm/V}$). Applying an input of 1.5V DC ± 0.5V (1.0 V to 2.0V) causes an output frequency change of 4.17 ppm (±2.08 ppm). If the control voltage bandwidth is specified as 10 kHz, the peak-to-peak value of the output frequency change will be reduced to $4.33 \text{ ppm}/\sqrt{2}$ or 2.95 ppm, as the frequency of the control voltage change is increased to 10 kHz.

FV Characteristic Slope K_V

The slope of the FV characteristic is a critical design parameter in many low bandwidth PLL applications. The slope is the derivative of the FV characteristic – the deviation of frequency divided by the control voltage change needed to produce that frequency deviation, over a small voltage span, as shown below:

$$K_V = \frac{\Delta f_{\text{out}}}{\Delta V_{\text{in}}}$$

It is typically expressed in kHz/Volt, MHz/Volt, ppm/Volt, or similar units. This slope is usually called “ K_V ” based on terminology used in PLL designs.

The extreme linear characteristic of the SiTime SiT5359 VCTCXO family means that there is very little K_V variation across the whole input voltage range (typically <1%), significantly reducing the design burden on the PLL designer. Figure 36 below illustrates the typical K_V variation.

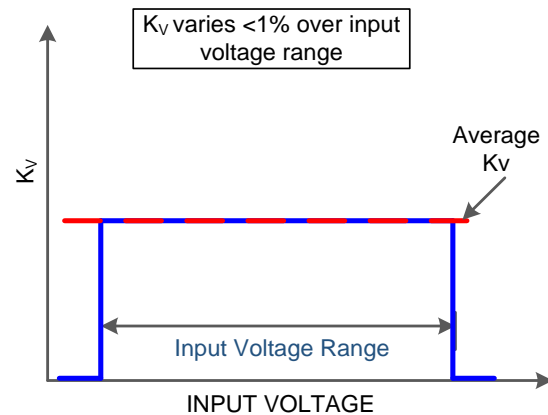

Figure 36. Typical SiTime K_V Variation

Pull Range, Absolute Pull Range

Pull range (PR) is the amount of frequency deviation that will result from changing the control voltage over its maximum range under nominal conditions.

Absolute pull range (APR) is the guaranteed controllable frequency range over all environmental and aging conditions. Effectively, it is the amount of pull range remaining after taking into account frequency stability, tolerances over variables such as temperature, power supply voltage, and aging, i.e.:

$$APR = PR - F_{\text{stability}} - F_{\text{aging}}$$

where $F_{\text{stability}}$ is the device frequency stability due to initial tolerance and variations on temperature, power supply, and load.

Figure 37 shows a typical SiTime VCTCXO FV characteristic. The FV characteristic varies with conditions, so that the frequency output at a given input voltage can vary by as much as the specified frequency stability of the VCTCXO. For such VCTCXOs, the frequency stability and APR are independent of each other. This allows very wide range of pull options without compromising frequency stability.

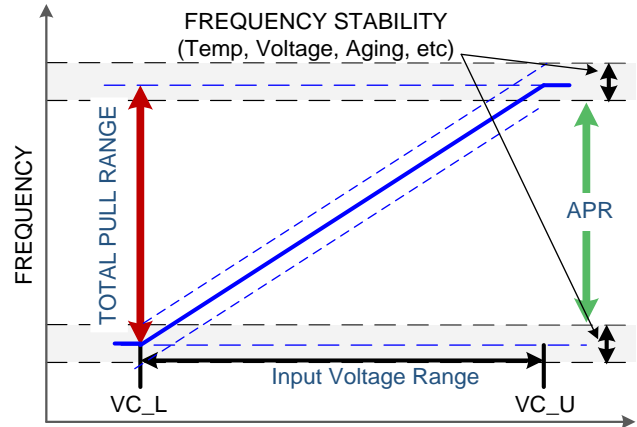

Figure 37. Typical SiTime VCTCXO FV Characteristic

The upper and lower control voltages are the specified limits of the input voltage range as shown in Figure 37 above. Applying voltages beyond the upper and lower voltages do not result in noticeable changes of output frequency. In other words, the FV characteristic of the VCTCXO saturates beyond these voltages. Figures 1 and 2 show these voltages as Lower Control Voltage (VC_L) and Upper Control Voltage (VC_U).

Table 13 below shows the pull range and corresponding APR values for each of the frequency vs. temperature ordering options.

Table 13. VCTCXO Pull Range, APR Options^[12]

Typical unless specified otherwise. Pull range (PR) is ±6.25 ppm.

Pull Range Ordering Code	Device Option(s)	APR ppm ±50 ppb option ±0.5 ppm 20-year aging
T	VCTCXO	±5.2

Notes:

12. APR includes initial tolerance, frequency stability vs. temperature, and the corresponding 20-year aging.

DCTCXO-Specific Design Considerations

Pull Range and Absolute Pull Range

Pull range and absolute pull range are described in the previous section. Table 14 below shows the pull range and corresponding APR values for each of the frequency vs. temperature ordering options.

Table 14. APR Options^[13]

Pull Range Ordering Code	Pull Range ppm	APR ppm ± 50 ppb option ± 0.5 ppm 20-year aging
T	± 6.25	± 5.2
R	± 10	± 8.95
Q	± 12.5	± 11.45
M	± 25	± 23.95
B	± 50	± 48.95
C	± 80	± 78.95
E	± 100	± 98.95
F	± 125	± 123.95
G	± 150	± 148.95
H	± 200	± 198.95
X	± 400	± 398.95
L	± 600	± 598.95
Y	± 800	± 798.95
S	± 1200	± 1198.95
Z	± 1600	± 1598.95
U	± 3200	± 3198.95

Notes:

13. APR includes initial tolerance, frequency stability vs. temperature, and the corresponding 20-year aging.

Output Frequency

The device powers up at the nominal operating frequency and pull range specified by the ordering code. After power-up both pull range and output frequency can be controlled via I²C writes to the respective control registers. The maximum output frequency change is constrained by the pull range limits.

The pull range is specified by the value loaded in the digital pull-range control register. The 16 pull range choices are specified in the control register and range from ±6.25 ppm to ±3200 ppm.

Table 15 below shows the frequency resolution versus pull range programmed value

Table 15. Frequency Resolution versus Pull Range

Programmed Pull Range	Frequency Resolution
±6.25ppm	5×10^{-12}
±10ppm	5×10^{-12}
±12.5ppm	5×10^{-12}
±25ppm	5×10^{-12}
±50ppm	5×10^{-12}
±80ppm	5×10^{-12}
±100ppm	5×10^{-12}
±120ppm	5×10^{-12}
±150ppm	5×10^{-12}
±200ppm	5×10^{-12}
±400ppm	1×10^{-11}
±600ppm	1.4×10^{-11}
±800ppm	2.1×10^{-11}
±1200ppm	3.2×10^{-11}
±1600ppm	4.7×10^{-11}
±3200ppm	9.4×10^{-11}

The ppm frequency offset is specified by the 26 bit DCXO frequency control register in two's complement format as described in the I²C Register Descriptions. The power up default value is 000000000000000000000000b which sets the output frequency at its nominal value (0 ppm). To change the output frequency, a frequency control word is written to 0x00[15:0] (Least Significant Word) and 0x01[9:0] (Most Significant Word). The LSW value should be written first followed by the MSW value; the frequency change is initiated after the MSW value is written.

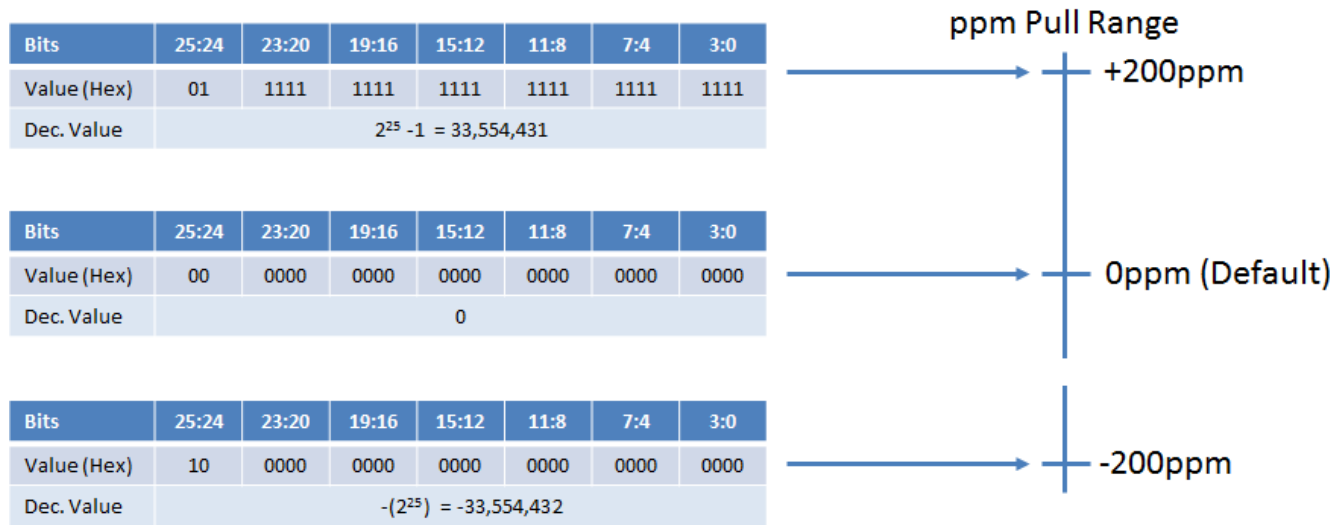

Figure 38. Pull Range and Frequency Control Word

Figure 38 shows how the two's complement signed value of the frequency control word sets the output frequency within the ppm pull range set by 0x02:[3:0]. This example shows use of the ±200 ppm pull range. Therefore, to set the desired output frequency, one just needs to calculate the fraction of full scale value ppm, convert to two's complement binary, and then write these values to the frequency control registers.

The following formula generates the control word value:

Control word value = $RND((2^{25}-1) \times \text{ppm shift from nominal/pull range})$, where RND is the rounding function which rounds the number to the nearest whole number. Two examples follow, assuming a ±200 ppm pull range:

Example 1:

- Default Output Frequency = 98.304 MHz
- Desired Output Frequency = 98.31284736 MHz (90 ppm)

$2^{25}-1$ corresponds to +200 ppm, and the fractional value required for +90 ppm can be calculated as follows.

■ $90 \text{ ppm} / 200 \text{ ppm} \times (2^{25}-1) = 15,099,493.95$.

Rounding to the nearest whole number yields 15,099,494 and converting to two's complement gives a binary value of 111001100110011001100110, or E66666 in hex.

Example 2:

- Default Output Frequency = 155.52 MHz
- Desired Output Frequency = 155.512224 MHz (-50 ppm)

Following the formula shown above,

■ $(-50 \text{ ppm} / 200 \text{ ppm}) \times (2^{25}-1) = -8,388,607.75$.

Rounding this to the nearest whole number results in -8,388,608.

Converting this to two's complement binary results in 111000000000000000000000, or 380000 in hex.

To summarize, the procedure for calculating the frequency control word associated with a given ppm offset is as follows:

- 1) Calculate the fraction of the half-pull range needed. For example, if the total pull range is set for ±100 ppm and a +20 ppm shift from the nominal frequency is needed, this fraction is 20 ppm/100 ppm = 0.2
- 2) Multiply this fraction by the full-half scale word value, $2^{25}-1 = 33,554,431$, round to the nearest whole number, and convert the result to two's complement binary. Following the +20ppm example, this value is $0.2 \times 33,554,431 = 6,710,886.2$ and rounded to 6,710,886.
- 3) Write the two's complement binary value starting with the Least Significant Word (LSW) 0x00[16:0], followed by the Most Significant Word (MSW), 0x01[9:0]. If the user desires that the output remains enabled while changing the frequency, a 1 must also be written to the OE control bit 0x01[10] if the device has software OE Control Enabled.

It is important to note that the maximum Digital Control update rate is 38 kHz regardless of I²C bus speed.

I²C Control Registers

The SiT5359 enables control of frequency pull range, frequency pull value, and Output Enable via I²C writes to the control registers. Table 16 below shows the register map summary, and detailed register descriptions follow.

Table 16. Register Map Summary

Address	Bits	Access	Description
0x00	[15:0]	RW	DIGITAL FREQUENCY CONTROL LEAST SIGNIFICANT WORD (LSW)
0x01	[15:11]	R	NOT USED
	[10]	RW	OE Control. This bit is only active if the output enable function is under software control. If the device is configured for hardware control using the OE pin, writing to this bit has no effect.
	[9:0]	RW	DIGITAL FREQUENCY CONTROL MOST SIGNIFICANT WORD (MSW)
0x02	[15:4]	R	NOT USED
	[3:0]	RW	DIGITAL PULL RANGE CONTROL

Register Descriptions

Register Address: 0x00. Digital Frequency Control Least Significant Word (LSW)

Bit	15	14	13	12	11	10	9	8	7	6	5	4	3	2	1	0
Access	RW	RW	RW	RW	RW	RW	RW	RW	RW	RW	RW	RW	RW	RW	RW	RW
Default	0	0	0	0	0	0	0	0	0	0	0	0	0	0	0	0
Name	DIGITAL FREQUENCY CONTROL LEAST SIGNIFICANT WORD (LSW)[15:0]															

Bits	Name	Access	Description
15:0	DIGITAL FREQUENCY CONTROL LEAST SIGNIFICANT WORD	RW	<p>Bits [15:0] are the lower 16 bits of the 26 bit FrequencyControlWord and are the Least Significant Word (LSW). The upper 10 bits are in register 0x01[9:0] and are the Most Significant Word (MSW). The lower 16 bits together with the upper 10 bits specify a 26-bit frequency control word.</p> <p>This power-up default values of all 26 bits are 0 which sets the output frequency at its nominal value. After power-up, the system can write to these two registers to pull the frequency across the pull range. The register values are two's complement to support positive and negative control values. The LSW value should be written before the MSW value because the frequency change is initiated when the new values are loaded into the MSW. More details and examples are discussed in the previous section.</p>

Register Address: 0x01. OE Control, Digital Frequency Control Most Significant Word (MSW)

Bit	15	14	13	12	11	10	9	8	7	6	5	4	3	2	1	0
Access	R	R	R	R	R	RW	RW	RW	RW	RW	RW	RW	RW	RW	RW	RW
Default	0	0	0	0	0	0	0	0	0	0	0	0	0	0	0	0
Name	NOT USED					OE	DCXO FREQUENCY CONTROL[9:0] MSW									

Bits	Name	Access	Description
15:11	NOT USED	R	Bits [15:10] are read only and return all 0's when read. Writing to these bits has no effect.
10	OE Control	RW	Output Enable Software Control. Allows the user to enable and disable the output driver via I ² C. 0 = Output Disabled (Default) 1 = Output Enabled This bit is only active if the Output Enable function is under software control. If the device is configured for hardware control using the OE pin, writing to this bit has no effect.
9:0	DIGITAL FREQUENCY CONTROL MOST SIGNIFICANT WORD (MSW)	RW	Bits [9:0] are the upper 10 bits of the 26 bit FrequencyControlWord and are the Most Significant Word (MSW). The lower 16 bits are in register 0x00[15:0] and are the Least Significant Word (LSW). These lower 16 bits together with the upper 10 bits specify a 26-bit frequency control word. This power-up default values of all 26 bits are 0 which sets the output frequency at its nominal value. After power-up, the system can write to these two registers to pull the frequency across the pull range. The register values are two's complement to support positive and negative control values. The LSW value should be written before the MSW value because the frequency change is initiated when the new values are loaded into the MSW. More details and examples are discussed in the previous section.

Register Address: 0x02. DIGITAL PULL RANGE CONTROL^[14]

Bit	15	14	13	12	11	10	9	6	5	6	5	4	3	2	1	0
Access	R	R	R	R	R	R	R	R	R	R	R	R	RW	RW	RW	RW
Default	0	0	0	0	0	0	0	0	0	0	0	0	X	X	X	X
Name	NONE												DIGITAL PULL RANGE CONTROL			

Notes:

14. Default values are factory set but can be over-written after power-up.

Bits	Name	Access	Description
15:4	NONE	R	Bits [15:4] are read only and return all 0's when read. Writing to these bits has no effect.
3:0	DIGITAL PULL RANGE CONTROL	RW	<p>Sets the digital pull range of the DCXO. The table below shows the available pull range values and associated bit settings. The default value is factory programmed.</p> <p>Bit 3 2 1 0</p> <p>0 0 0 0: ±6.25ppm 0 0 0 1: ±10ppm 0 0 1 0: ±12.5ppm 0 0 1 1: ±25ppm 0 1 0 0: ±50ppm 0 1 0 1: ±80ppm 0 1 1 0: ±100ppm 0 1 1 1: ±125ppm 1 0 0 0: ±150ppm 1 0 0 1: ±200ppm 1 0 1 0: ±400ppm 1 0 1 1: ±600ppm 1 1 0 0: ±800ppm 1 1 0 1: ±1200ppm 1 1 1 0: ±1600ppm 1 1 1 1: ±3200ppm</p>

Serial Interface Configuration Description

The SiT5359 includes an I²C interface to access registers that control the DCTCXO frequency pull range, and frequency pull value. The SiT5359 I²C slave-only interface supports clock speeds up to 1 MHz. The SiT5359 I²C module is based on the I²C specification, UM1024 (Rev.6 April 4, 2014 of NXP Semiconductor).

Serial Signal Format

The SDA line must be stable during the high period of the SCL. SDA transitions are allowed only during SCL low level for data communication. Only one transition is allowed during the low SCL state to communicate one bit of data. [Figure 39](#) shows the detailed timing diagram.

An idle I²C bus state occurs when both SCL and SDA are not being driven by any master and are therefore in a logic HI state due to the pull up resistors. Every transaction begins with a START (S) signal and ends with a STOP (P) signal. A START condition is defined by a high to low transition on the SDA while SCL is high. A STOP condition is defined by a low to high transition on the SDA while SCL is high. START and STOP conditions are always generated by the master. This slave module also supports repeated START (Sr) condition which is same as START condition instead of STOP condition (the blue-color line shows repeated START in [Figure 40](#)).

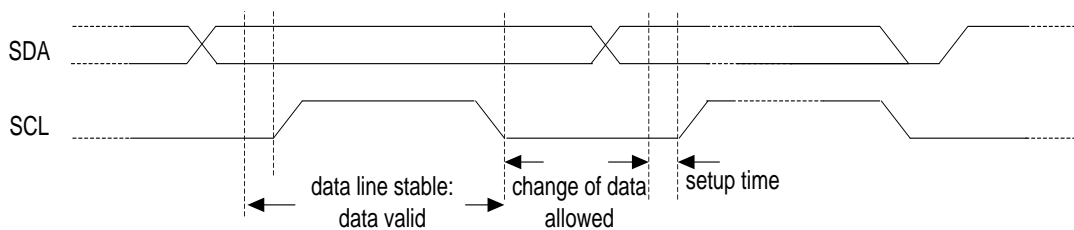

Figure 39. Data and clock timing relation in I²C bus

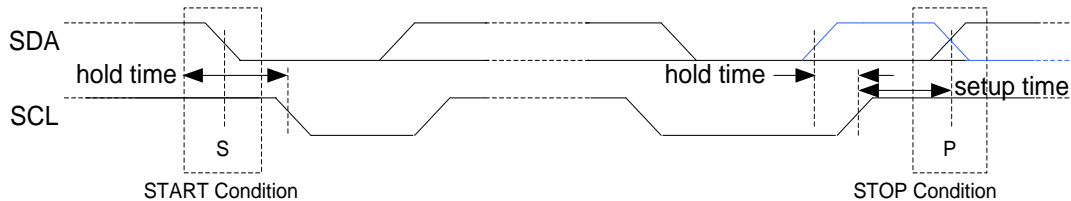

Figure 40. START and STOP (or repeated START, blue line) condition

Parallel Signal Format

Every data byte is 8 bits long. The number of bytes that can be transmitted per transfer is unrestricted. Data is transferred with the MSB (Most Significant Bit) first. The detailed data transfer format is shown in Figure 42 below.

The acknowledge bit must occur after every byte transfer and it allows the receiver to signal the transmitter that the byte was successfully received and another byte may be sent. The acknowledge signal is defined as follows: the transmitter releases the SDA line during the acknowledge clock pulse so the receiver can pull the SDA line low and it remains stable low during the high period of this clock pulse. Setup and hold times must also be taken into account. When SDA remains high during this ninth clock pulse, this is defined as the Not-Acknowledge signal (NACK). The master can then generate either a STOP condition to abort the transfer, or a repeated START condition to start a new transfer. The only condition that leads to the generation of NACK from the SiT5359 is when the transmitted address does not match the slave address. When the master is reading data from the SiT5359, the SiT5359 expects the ACK from the master at the end of received data, so that the slave releases the SDA line and the master can generate the STOP or repeated START. If there is a NACK signal at the end of the data, then the SiT5359 tries to send the next data. If the first bit of the next data is “0”, then the SiT5359 holds the SDA line to “0”, thereby blocking the master from generating a STOP/(re)START signal.

Parallel Data Format

This I²C slave module supports 7-bit device addressing format. The 8th bit is a read/write bit and “0” indicates a read transaction and a “1” indicates a write transaction. The register addresses are 8-bits long with an address range of 0 to 255 (00h to FFh). Auto address incrementing is supported which allows data to be transferred to contiguous addresses without the need to write each address beyond the first address. Since the maximum register address value is 255, the address will roll from 255 back to 0 when auto address incrementing is used. Obviously, auto address incrementing should only be used for writing to contiguous addresses. The data format is 16-bit (two bytes) with the most significant byte being transferred first.

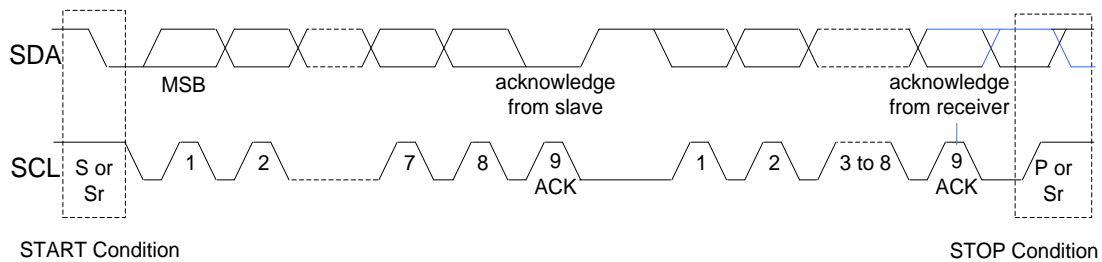

Figure 41. Parallel signaling format

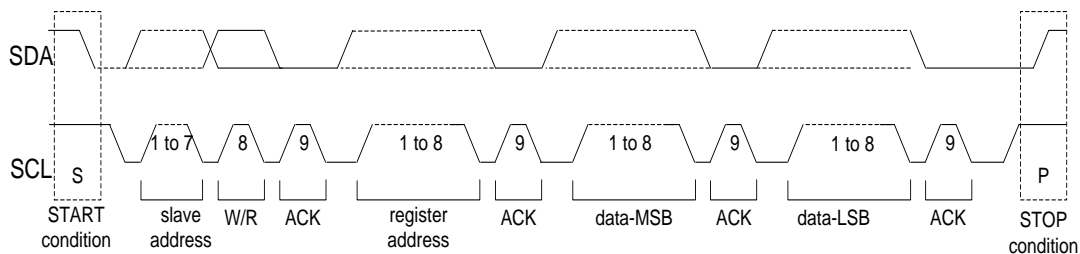

Figure 42. Parallel data byte format

Figure 43 below shows the I²C sequence for writing the 4-byte control word using auto address incrementing.

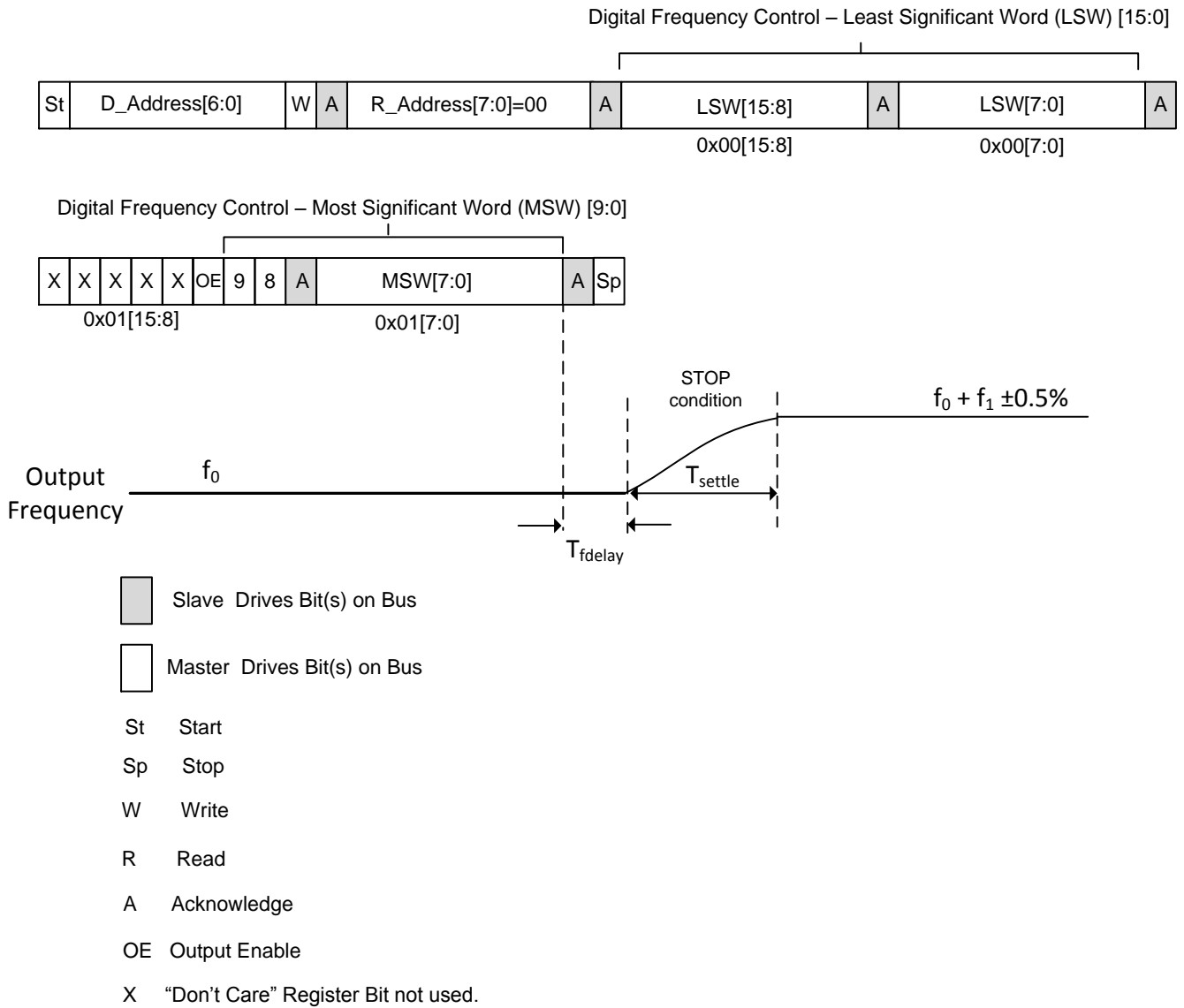

Figure 43. Writing the Frequency Control Word

Table 17. DCTCXO Delay and Settling Time

Parameter	Symbol	Minimum	Typical	Maximum	Units	Notes
Frequency Change Delay	T_{fdelay}	–	22	–	µsec	
Frequency Settling Time	T_{settle}	–	30	–	µsec	Time to settle to 1% of final frequency value.

I²C Timing Specification

The below timing diagram and table illustrate the timing relationships for both master and slave.

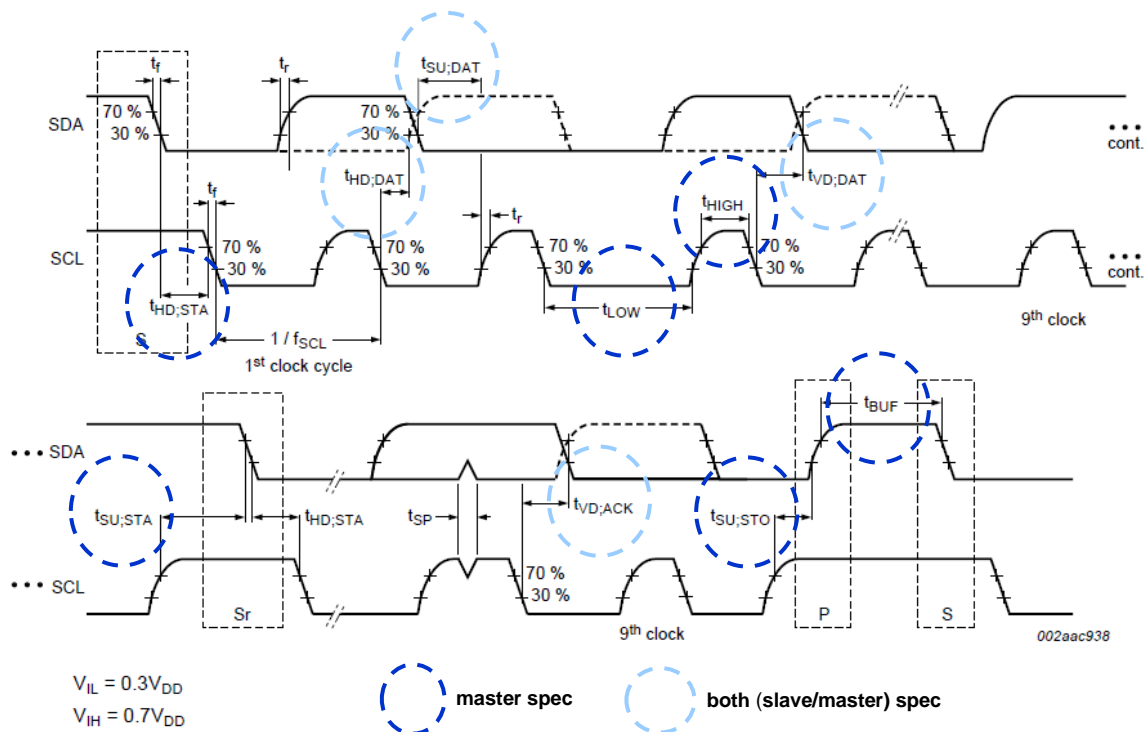

Figure 44. I²C Timing Diagram

Table 18. I²C Timing Requirements

Parameter	Speed Mode	Value	Unit
t _{SETUP}	FM+ (1 MHz)	> 50	nsec
	FM (400KHz)	> 100	nsec
	SM (100KHz)	> 250	nsec
t _{HOLD}	FM+ (1 MHz)	> 0	nsec
	FM (400KHz)	> 0	nsec
	SM (100KHz)	> 0	nsec
t _{VD:AWK}	FM+	> 450	nsec
	FM (400KHz)	> 900	nsec
	SM (100KHz)	> 3450	nsec
t _{VD:DAT}		NA (s-awk + s-data)/(m-awk/s-data)	

I²C Device Address Modes

There are two I²C address modes:

- 1) Factory Programmed Mode. The lower 4 bits of the 7-bit device address are set by ordering code as shown in [Table 19](#) below. There are 16 factory programmed addresses available. In this mode, pin 5 is NC and the A0 I²C address pin control function is not available.
- 2) A0 Pin Control. This mode allows the user to select between two I²C Device addresses as shown in [Table 20](#).

Table 19. Factory Programmed I²C Address Control^[15]

I ² C Address Ordering Code	Device I ² C Address
0	1100000
1	1100001
2	1100010
3	1100011
4	1100100
5	1100101
6	1100110
7	1100111
8	1101000
9	1101001
A	1101010
B	1101011
C	1101100
D	1101101
E	1101110
F	1101111

Notes:

15. Table 19 is only valid for the DCTCXO device option which supports I²C Control.

Table 20. Pin Selectable I²C Address Control^[16]

A0 Pin 5	I ² C Address
0	1100010
1	1101010

Notes:

16. Table 20 is only valid for the DCTCXO device option which supports I²C control and A0 Device Address Control Pin.

Schematic Example

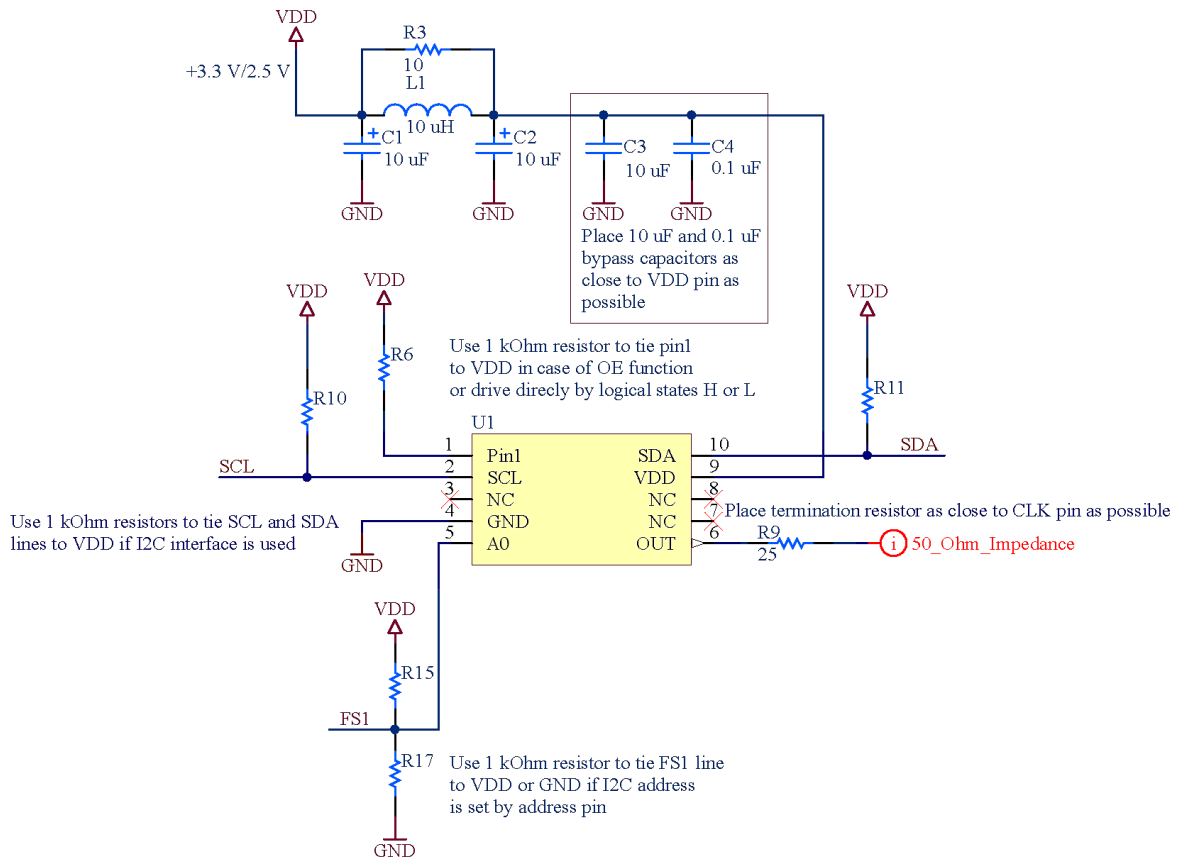

Figure 45. DCTCXO schematic example.

Dimensions and Patterns

Package Size – Dimensions (Unit: mm)

(TOP VIEW)

(BOTTOM VIEW)

(SIDE VIEW)

	SYMBOL	MIN	NOM	MAX	
TOTAL THICKNESS	A	0.840	0.950	1.060	
BODY SIZE	X	D	4.850	5.000	5.150
	Y	E	3.050	3.200	3.350
LEAD PITCH	e	1.070	1.200	0.330	
	e1	1.200	1.350	1.480	
	e2	0.970	1.100	1.230	
LEAD LENGTH	L	0.970	1.100	1.230	
	L1	0.770	0.900	1.030	
LEAD WIDTH	W	0.470	0.600	0.730	
	W1	0.670	0.800	0.930	
	W2	0.470	0.600	0.730	

NOTES

1. Dimensioning and tolerancing conform to ASME Y14.5-2009.
2. All dimensions are in millimeters.

TITLE		DWG. NO.	
10L CQFN		POD-CQFN-010-E05032-036	
3.200x5.000x0.950mm		REV.	SHEET
DATE	29-JUN-2018	A01	1 OF 1

Recommended Land Pattern (Unit: mm)

Solder Print Layout	
10L Ceramic	
5.0x3.2x0.95	
2017/06/20	

Layout Guidelines

- The SiT5359 uses internal regulators to minimize the impact of power supply noise. For further reduction of noise, it is essential to use two bypass capacitors (0.1 μ F and 10 μ F). Place the bypass capacitors as close to Vdd pin as possible, typically within 1 to 2 mm. Ensure that the 0.1 μ F cap is closer to the device Vdd and GND power pins.
- It is also recommended to connect all NC pins to the ground plane and place multiple vias under the GND pin for maximum heat dissipation.
- For additional layout recommendations, refer to the [Best Design Layout Practices](#).

Manufacturing Guidelines

The SiT5359 Super-TCXOs are precision timing devices. **Proper PCB solder and cleaning processes** must be followed to ensure best performance and long-term reliability.

- **No Ultrasonic or Megasonic Cleaning:** Do not subject the SiT5359 to an ultrasonic or megasonic cleaning environment. Otherwise, permanent damage or long-term reliability issues to the device may result.
- **No external cover.** Unlike legacy quartz TCXOs, the SiT5359 is engineered to operate reliably, without performance degradation, in the presence of ambient disturbers such as airflow and sudden temperature changes. Therefore, the use of an external cover typically required by quartz TCXOs is not needed.
- **Reflow profile:** For mounting these devices to the PCB, IPC/JEDEC J-STD-020 compliant reflow profile must be used. Device performance is not guaranteed if soldered manually or with a non-compliant reflow profile.
- **PCB cleaning:** after the surface mount (SMT)/reflow process, solder flux residues may be present on the PCB and around the pads of the device. Excess residual solder flux may lead to problems such as pad corrosion, elevated leakage currents, increased frequency aging, or other performance degradation. For optimal device performance and long-term reliability, thorough cleaning and drying of the PCB is required as shortly after the reflow process as possible, even when using a “no clean” flux. Care should be taken to remove all residual flux between the SiTime device and the PCB. Note that ultrasonic PCB cleaning should not be used with SiTime oscillators.
- For additional manufacturing guidelines and marking/tape-reel instructions, refer to [SiTime Manufacturing Notes](#).

Table 21. Additional Information

Document	Description	Download Link
Time Machine II	MEMS oscillator programmer	http://www.sitime.com/support/time-machine-oscillator-programmer
Field Programmable Oscillators	Devices that can be programmable in the field by Time Machine II	http://www.sitime.com/products/field-programmable-oscillators
Manufacturing Notes	Tape & Reel dimension, reflow profile and other manufacturing related info	http://www.sitime.com/manufacturing-notes
Qualification Reports	RoHS report, reliability reports, composition reports	http://www.sitime.com/support/quality-and-reliability
Performance Reports	Additional performance data such as phase noise, current consumption and jitter for selected frequencies	http://www.sitime.com/support/performance-measurement-report
Termination Techniques	Termination design recommendations	http://www.sitime.com/support/application-notes
Layout Techniques	Layout recommendations	http://www.sitime.com/support/application-notes

Table 22. Revision History

Version	Release Date	Change Summary
0.1	05/10/2016	First release, advanced information
0.15	08/04/2016	Replaced QFN package with SOIC-8 package Added 10 µF bypass cap requirement Updated test circuits to reflect both new bypass cap requirement and SOIC-8 package Update Table 1 (Electrical Characteristics)
0.16	09/12/2016	Updated test circuit diagrams
0.2	09/21/2016	Revised Table 1 (Electrical Characteristics)
0.51	08/20/2017	Changed to preliminary Added D2TCXO mode Added I2C information Added 5.0x3.2 mm ² package information Updated test circuits Updated Table 1 (Electrical Characteristics) Updated part ordering info Misc. corrections
0.52	11/27/2017	Updated the Thermal Characteristics table Added more on Manufacturing Guideline section
0.55	02/05/2018	Added View labels to Package Drawings Updated links and notes
0.60	03/01/2018	Added 105°C support, updated Ordering Information
0.9	07/06/2018	Updated Electrical Characteristics tables. Added Typical Performance Plots. Improved readability. Fixed bad hyperlinks.
0.91	08/02/2018	Updated conditions for one day and one year aging specs. Updated package outline drawing. Revised phase noise specifications. Various formatting updates.

SiTime Corporation, 5451 Patrick Henry Drive, Santa Clara, CA 95054, USA | Phone: +1-408-328-4400 | Fax: +1-408-328-4439

© SiTime Corporation 2016-2018. The information contained herein is subject to change at any time without notice. SiTime assumes no responsibility or liability for any loss, damage or defect of a Product which is caused in whole or in part by (i) use of any circuitry other than circuitry embodied in a SiTime product, (ii) misuse or abuse including static discharge, neglect or accident, (iii) unauthorized modification or repairs which have been soldered or altered during assembly and are not capable of being tested by SiTime under its normal test conditions, or (iv) improper installation, storage, handling, warehousing or transportation, or (v) being subjected to unusual physical, thermal, or electrical stress.

Disclaimer: SiTime makes no warranty of any kind, express or implied, with regard to this material, and specifically disclaims any and all express or implied warranties, either in fact or by operation of law, statutory or otherwise, including the implied warranties of merchantability and fitness for use or a particular purpose, and any implied warranty arising from course of dealing or usage of trade, as well as any common-law duties relating to accuracy or lack of negligence, with respect to this material, any SiTime product and any product documentation. Products sold by SiTime are not suitable or intended to be used in a life support application or component, to operate nuclear facilities, or in other mission critical applications where human life may be involved or at stake. All sales are made conditioned upon compliance with the critical uses policy set forth below.

CRITICAL USE EXCLUSION POLICY

BUYER AGREES NOT TO USE SITIME'S PRODUCTS FOR ANY APPLICATION OR IN ANY COMPONENTS USED IN LIFE SUPPORT DEVICES OR TO OPERATE NUCLEAR FACILITIES OR FOR USE IN OTHER MISSION-CRITICAL APPLICATIONS OR COMPONENTS WHERE HUMAN LIFE OR PROPERTY MAY BE AT STAKE.

SiTime owns all rights, title and interest to the intellectual property related to SiTime's products, including any software, firmware, copyright, patent, or trademark. The sale of SiTime products does not convey or imply any license under patent or other rights. SiTime retains the copyright and trademark rights in all documents, catalogs and plans supplied pursuant to or ancillary to the sale of products or services by SiTime. Unless otherwise agreed to in writing by SiTime, any reproduction, modification, translation, compilation, or representation of this material shall be strictly prohibited.