

# bq24311 Overvoltage and Overcurrent Protection IC and Li+ Charger Front-End Protection IC

## 1 Features

- Provides Protection for Three Variables:
  - Input Overvoltage, with Rapid Response in  $< 1 \mu\text{s}$
  - User-Programmable Overcurrent with Current Limiting
  - Battery Overvoltage
- 30 V Maximum Input Voltage
- Supports up to 0.3 A Input Current
- Robust Against False Triggering Due to Current Transients
- Thermal Shutdown
- Enable Input
- Status Indication – Fault Condition

## 2 Applications

- Mobile Phones and Smart Phones
- PDAs
- MP3 Players
- Low-Power Handheld Devices
- Bluetooth™ Headsets

## 4 Application Information

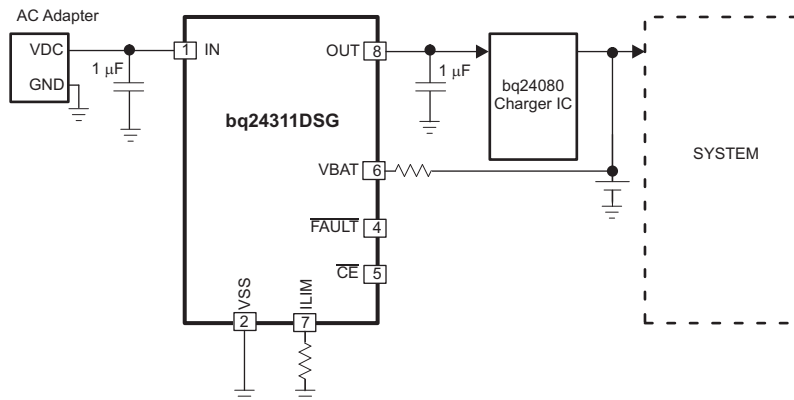

## 3 Description

The bq24311 is a highly integrated circuit designed to protect Li-ion batteries from charging circuit failures. The IC continuously monitors the input voltage, input current, and battery voltage. The input overvoltage protection immediately removes power from the charging circuit by turning off an internal switch. The input protection limits the system current at the user-programmable value, and if the overcurrent persists, switches the pass element OFF after a blanking period. Additionally, the IC also monitors its own die temperature and switches off if it becomes too hot.

The IC can be controlled by a processor and also provides status information about fault conditions to the host.

### Device Information

PART NUMBER	PACKAGE	BODY SIZE (NOM)
bq24311	WSON (8)	2.00mm x 2.00mm

(1) For all available packages, see the orderable addendum at the end of the datasheet.



## Table of Contents

<b>1 Features</b> .....	<b>1</b>	8.1 Overview .....	<b>8</b>
<b>2 Applications</b> .....	<b>1</b>	8.2 Functional Block Diagram .....	<b>8</b>
<b>3 Description</b> .....	<b>1</b>	8.3 Feature Description .....	<b>9</b>
<b>4 Application Information</b> .....	<b>1</b>	8.4 Device Functional Modes .....	<b>9</b>
<b>5 Revision History</b> .....	<b>2</b>	<b>9 Application and Implementation</b> .....	<b>12</b>
<b>6 Pin Configuration and Functions</b> .....	<b>3</b>	9.1 Typical Application Circuit .....	<b>12</b>
<b>7 Specifications</b> .....	<b>4</b>	<b>10 Power Supply Requirements</b> .....	<b>16</b>
7.1 Absolute Maximum Ratings .....	<b>4</b>	<b>11 Layout</b> .....	<b>17</b>
7.2 Handling Ratings .....	<b>4</b>	11.1 Layout Guidelines .....	<b>17</b>
7.3 Recommended Operating Conditions .....	<b>4</b>	11.2 Layout Example .....	<b>17</b>
7.4 Thermal Information .....	<b>4</b>	<b>12 Device and Documentation Support</b> .....	<b>18</b>
7.5 Electrical Characteristics .....	<b>5</b>	12.1 Trademarks .....	<b>18</b>
7.6 Timing Requirements .....	<b>5</b>	12.2 Electrostatic Discharge Caution .....	<b>18</b>
7.7 Typical Characteristics .....	<b>6</b>	12.3 Glossary .....	<b>18</b>
<b>8 Detailed Description</b> .....	<b>8</b>	<b>13 Mechanical, Packaging, and Orderable Information</b> .....	<b>18</b>

## 5 Revision History

Date	Revision	Notes
June	*	Initial release.

## 6 Pin Configuration and Functions

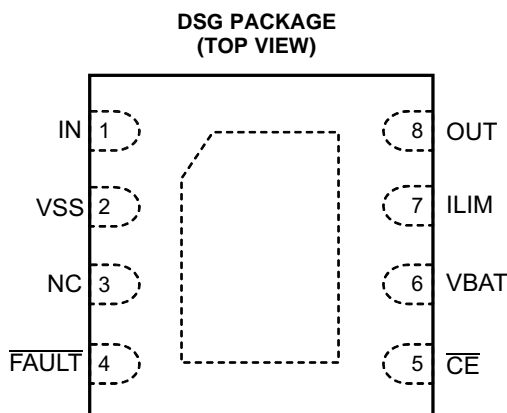

### Pin Functions

PIN		I/O	DESCRIPTION
NAME	DSG		
IN	1	I	Input power, connect to external DC supply. Connect external 1µF ceramic capacitor (minimum) to VSS.
OUT	8	O	Output pin to the charging system. Connect external 1 µF ceramic capacitor (minimum) to VSS.
VBAT	6	I	Battery voltage sense input. Connect to pack positive pin through a resistor.
ILIM	7	I/O	Input overcurrent threshold programming. Connect a resistor to VSS to set the overcurrent threshold.
$\overline{\text{CE}}$	5	I	Chip enable input. Active low. When $\overline{\text{CE}}$ = High, the input FET is off. Internally pulled down.
$\overline{\text{FAULT}}$	4	O	Device status, open-drain output. $\overline{\text{FAULT}}$ = Low indicates that the input FET Q1 has been turned on due to input overvoltage, input overcurrent, battery overvoltage, or thermal shutdown.
VSS	2	–	Ground pin
NC	3		This pin may have internal circuits used for test purposes. Do not make any external connections at these pins for normal operation.
Thermal PAD		–	There is an internal electrical connection between the exposed thermal pad and the VSS pin of the device. The thermal pad must be connected to the same potential as the VSS pin on the printed circuit board. Do not use the thermal pad as the primary ground input for the device. The VSS pin must be connected to ground at all times.

## 7 Specifications

### 7.1 Absolute Maximum Ratings<sup>(1)</sup>

over operating free-air temperature range (unless otherwise noted)

PARAMETER		MIN	MAX	UNIT
Input voltage	IN (with respect to VSS)	–0.3	30	V
	OUT (with respect to VSS)	–0.3	12	
	ILIM, FAULT, CE, VBAT (with respect to VSS)	–0.3	7	
Input current	IN		0.5	A
Output current	OUT		0.5	A
Output sink current	FAULT		15	mA
Junction temperature, T <sub>J</sub>		–40	150	°C

(1) JEDEC document JEP155 states that 500-V HBM allows safe manufacturing with a standard ESD control process.

### 7.2 Handling Ratings

		MIN	MAX	UNIT	
T <sub>stg</sub>	Storage temperature range	–65	150	°C	
V <sub>ESD</sub>	Electrostatic discharge	Human body model (HBM), per ANSI/ESDA/JEDEC JS-001, all pins <sup>(1)</sup>	–2000	2000	V
		Charged device model (CDM), per JEDEC specification JESD22-C101, all pins <sup>(2)</sup>	–500	500	V

(1) JEDEC document JEP155 states that 500-V HBM allows safe manufacturing with a standard ESD control process.

(2) (2) JEDEC document JEP157 states that 250-V CDM allows safe manufacturing with a standard ESD control process.

### 7.3 Recommended Operating Conditions

over operating free-air temperature range (unless otherwise noted)

		MIN	MAX	UNIT
V <sub>IN</sub>	Input voltage range	3	26	V
I <sub>IN</sub>	Input current, IN pin	50	300	mA
I <sub>OUT</sub>	Output current, OUT pin	50	300	mA
R <sub>ILIM</sub>	OCP Programming resistor	83.3	500	kΩ
T <sub>J</sub>	Junction temperature	–40	125	°C

### 7.4 Thermal Information

THERMAL METRIC <sup>(1)</sup>	DSG	UNITS	
	8 PINS		
R <sub>θJA</sub>	Junction-to-ambient thermal resistance	86.3	°C/W
R <sub>θJctop</sub>	Junction-to-case (top) thermal resistance	116.9	
R <sub>θJB</sub>	Junction-to-board thermal resistance	56.1	
Ψ <sub>JT</sub>	Junction-to-top characterization parameter	8.1	
Ψ <sub>JB</sub>	Junction-to-board characterization parameter	56.4	
R <sub>θJcbot</sub>	Junction-to-case (bottom) thermal resistance	25.9	

(1) For more information about traditional and new thermal metrics, see the *IC Package Thermal Metrics* application report, [SPRA953](http://www.ti.com/lit/zip/SR9953).

## 7.5 Electrical Characteristics

over junction temperature range  $-40^{\circ}\text{C}$  to  $125^{\circ}\text{C}$  and recommended supply voltage (unless otherwise noted)

PARAMETER		TEST CONDITIONS	MIN	TYP	MAX	UNIT
<b>IN</b>						
$V_{(UVLO)}$	Undervoltage lock-out, input power detected threshold	$\overline{\text{CE}} = \text{Low}$ , $V_{\text{IN}}$ increasing from 0 V to 3 V	2.6	2.7	2.8	V
$V_{(UVLO\_HYS)}$	Hysteresis on UVLO	$\overline{\text{CE}} = \text{Low}$ , $V_{\text{IN}}$ decreasing from 3 V to 0 V	200	260	300	mV
$I_{\text{DD}}$	Operating current	$\overline{\text{CE}} = \text{Low}$ , No load on OUT pin, $V_{\text{IN}} = 5\text{ V}$ , $R_{(\text{ILIM})} = 200\text{ k}\Omega$		400	500	$\mu\text{A}$
$I_{(\text{STDBY})}$	Standby current	$\overline{\text{CE}} = \text{High}$ , $V_{\text{IN}} = 5\text{ V}$		65	95	$\mu\text{A}$
<b>INPUT TO OUTPUT CHARACTERISTICS</b>						
$V_{(\text{DO})}$	Drop-out voltage IN to OUT	$\overline{\text{CE}} = \text{Low}$ , $V_{\text{IN}} = 5\text{ V}$ , $I_{\text{OUT}} = 0.125\text{ A}$		21	35	mV
<b>INPUT OVERVOLTAGE PROTECTION</b>						
$V_{(\text{OVP})}$	Input overvoltage protection threshold	$\overline{\text{CE}} = \text{Low}$ , $V_{\text{IN}}$ increasing from 5V to 7.5 V	5.71	5.85	6.00	V
$V_{(\text{HYS-OVP})}$	Hysteresis on OVP	$\overline{\text{CE}} = \text{Low}$ , $V_{\text{IN}}$ decreasing from 7.5 V to 5 V	20	60	110	mV
<b>INPUT OVERCURRENT PROTECTION</b>						
$I_{(\text{OCP})}$	Input overcurrent protection threshold range		50		300	mA
	Input overcurrent protection threshold	$\overline{\text{CE}} = \text{Low}$ , $R_{\text{ILIM}} = 200\text{ k}\Omega$ , $3\text{ V} \leq V_{\text{IN}} < V_{\text{OVP}}$				
		$T_{\text{J}} = 0^{\circ}\text{C}$ to $85^{\circ}\text{C}$	110	125	135	mA
		$T_{\text{J}} = 0^{\circ}\text{C}$ to $125^{\circ}\text{C}$	110	125	140	
<b>BATTERY OVERVOLTAGE PROTECTION</b>						
$V_{(\text{BOVP})}$	Battery overvoltage protection threshold	$\overline{\text{CE}} = \text{Low}$ , $V_{\text{IN}} > 4.4\text{ V}$	4.30	4.35	4.4	V
$V_{(\text{HYS-BOVP})}$	Hysteresis on $V_{(\text{BOVP})}$	$\overline{\text{CE}} = \text{Low}$ , $V_{\text{IN}} > 4.4\text{ V}$	200	275	320	mV
$I_{(\text{VBAT})}$	Input bias current on VBAT pin	$V_{\text{BAT}} = 4.4\text{ V}$ , $T_{\text{J}} = 25^{\circ}\text{C}$			10	nA
<b>THERMAL PROTECTION</b>						
$T_{\text{J}(\text{OFF})}$	Thermal shutdown temperature			140	150	$^{\circ}\text{C}$
$T_{\text{J}(\text{OFF-HYS})}$	Thermal shutdown hysteresis			20		$^{\circ}\text{C}$
<b>LOGIC LEVELS ON <math>\overline{\text{CE}}</math></b>						
$V_{\text{IL}}$	Low-level input voltage		0		0.4	V
$V_{\text{IH}}$	High-level input voltage		1.4			V
$I_{\text{IL}}$	Low-level input current	$V_{\text{CE}} = 0\text{ V}$			1	$\mu\text{A}$
$I_{\text{IH}}$	High-level input current	$V_{\text{CE}} = 1.8\text{ V}$			15	$\mu\text{A}$
<b>LOGIC LEVELS ON <math>\overline{\text{FAULT}}</math></b>						
$V_{\text{OL}}$	Output low voltage	$I_{(\text{SINK})} = 5\text{ mA}$			0.2	V
$I_{(\text{HI-Z})}$	Leakage current, $\overline{\text{FAULT}}$ pin HI-Z	$V_{(\text{FAULT})} = 5\text{ V}$			10	$\mu\text{A}$

## 7.6 Timing Requirements

			MIN	TYP	MAX	UNIT
$t_{\text{DGL}(\text{PGOOD})}$	Deglitch time, input power detected status	$\overline{\text{CE}} = \text{Low}$ . Time measured from $V_{\text{IN}} 0\text{ V} \rightarrow 5\text{ V}$ 1 $\mu\text{s}$ rise-time, to output turning ON		8		ms
$t_{\text{PD}(\text{OVP})}$	Input OV propagation delay <sup>(1)</sup>	$\overline{\text{CE}} = \text{Low}$			1	$\mu\text{s}$
$t_{\text{ON}(\text{OVP})}$	Recovery time from input overvoltage condition	$\overline{\text{CE}} = \text{Low}$ , Time measured from $V_{\text{IN}} 7.5\text{ V} \rightarrow 5\text{ V}$ , 1 $\mu\text{s}$ fall-time		8		ms
$t_{\text{BLANK}(\text{OCP})}$	Blanking time, input overcurrent detected			176		$\mu\text{s}$
$t_{\text{REC}(\text{OCP})}$	Recovery time from input overcurrent condition			64		ms
$t_{\text{DGL}(\text{BOVP})}$	Deglitch time, battery overvoltage detected	$\overline{\text{CE}} = \text{Low}$ , $V_{\text{IN}} > 4.4\text{ V}$ . Time measured from $V_{(\text{VBAT})}$ rising from 4.1 V to 4.4 V to $\overline{\text{FAULT}}$ going low.		176		$\mu\text{s}$

(1) Not tested in production. Specified by design.

## 7.7 Typical Characteristics

Test conditions (unless otherwise noted) for typical operating performance:  $V_{IN} = 5\text{ V}$ ,  $C_{IN} = 1\ \mu\text{F}$ ,  $C_{OUT} = 1\ \mu\text{F}$ ,  $R_{(LIM)} = 200\ \text{k}\Omega$ ,  $R_{(BAT)} = 100\ \text{k}\Omega$ ,  $T_A = 25^\circ\text{C}$ ,  $V_{(PU)} = 3.3\ \text{V}$  (see Figure 11 for the Typical Application Circuit)

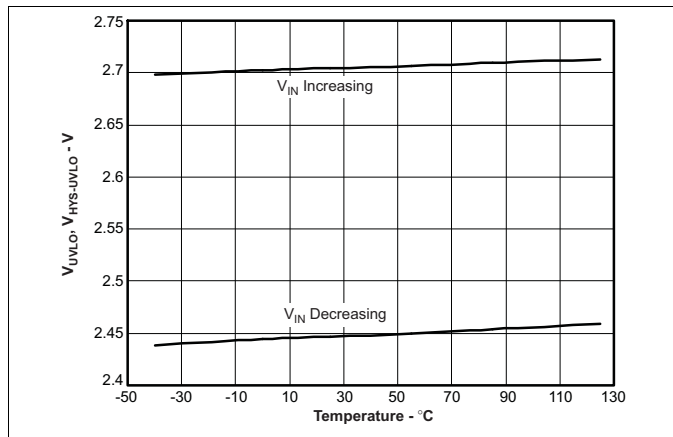

Figure 1. Undervoltage Lockout vs Free-Air Temperature

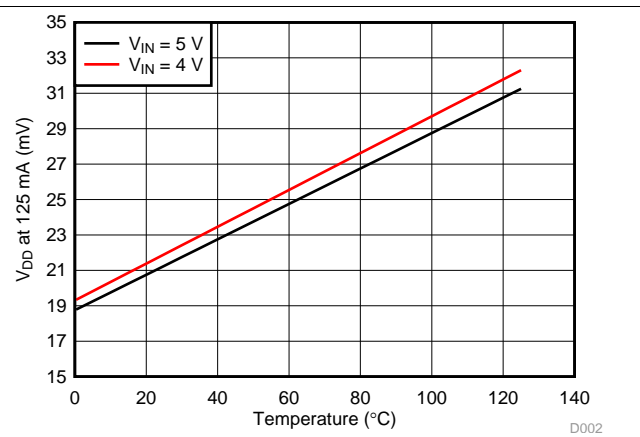

Figure 2. Dropout Voltage (In to Out) vs Free-Air Temperature

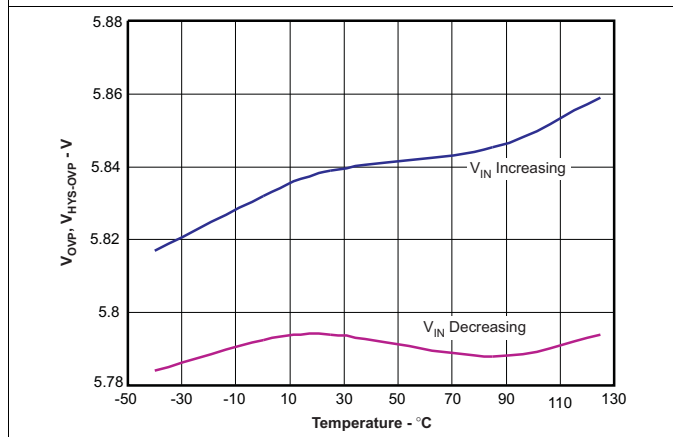

Figure 3. Overvoltage Threshold Protection vs Free-Air Temperature

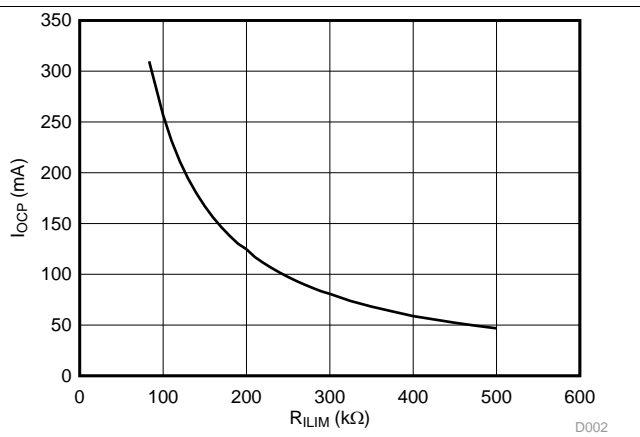

Figure 4. Input Overcurrent Protection vs ILIM Resistance

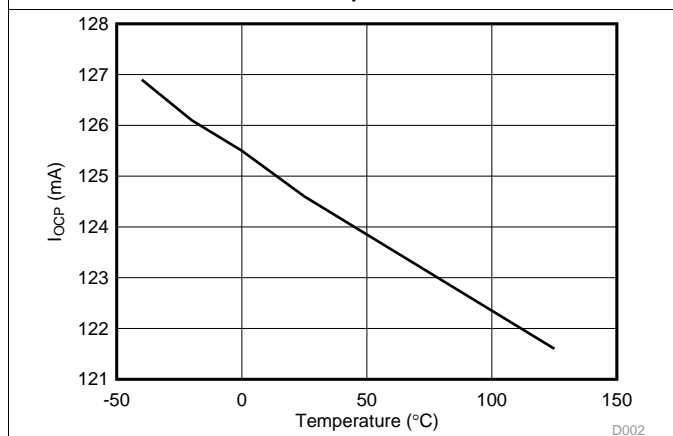

Figure 5. Input Overcurrent Protection vs Free-Air Temperature

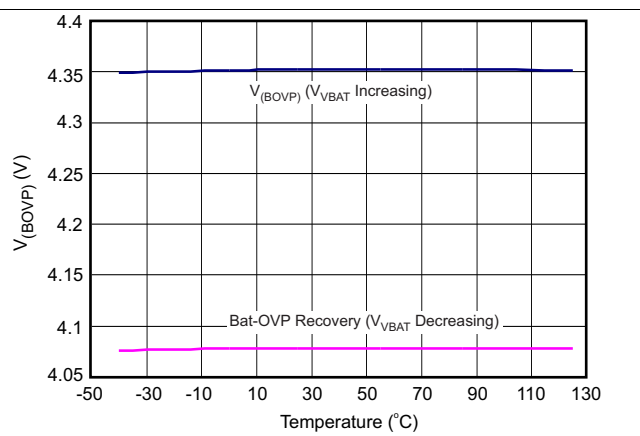
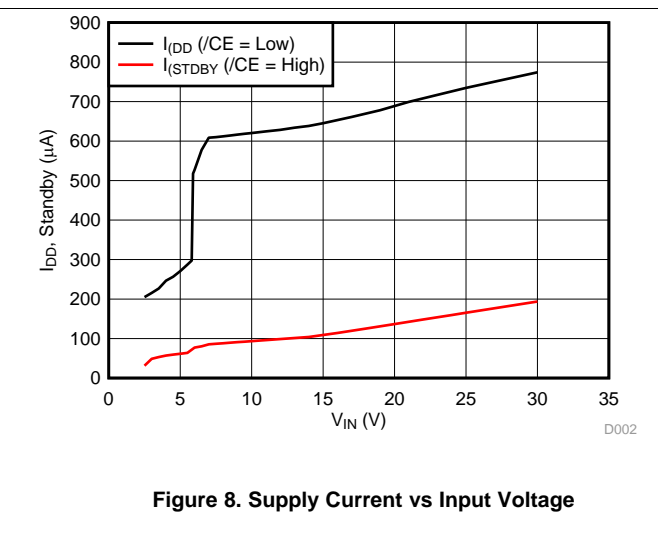
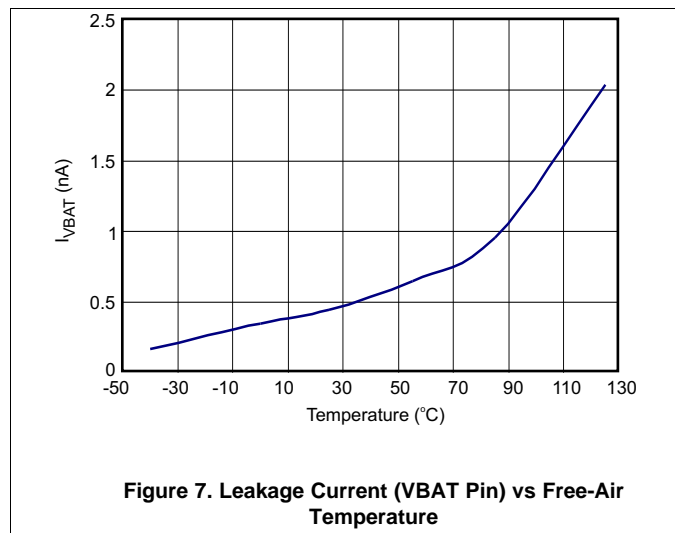

Figure 6. Battery Overvoltage Protection vs Free-Air Temperature

**Typical Characteristics (continued)**



## 8 Detailed Description

### 8.1 Overview

The bq24311 is a highly integrated circuit designed to protect Li-ion batteries from charging circuit failures. The IC continuously monitors the input voltage, input current, and battery voltage. The input overvoltage protection immediately removes power from the charging circuit by turning off an internal switch. The input protection limits the system current at the user-programmable value, and if the overcurrent persists, switches the pass element OFF after a blanking period. Additionally, the IC also monitors its own die temperature and switches off if it becomes too hot.

### 8.2 Functional Block Diagram

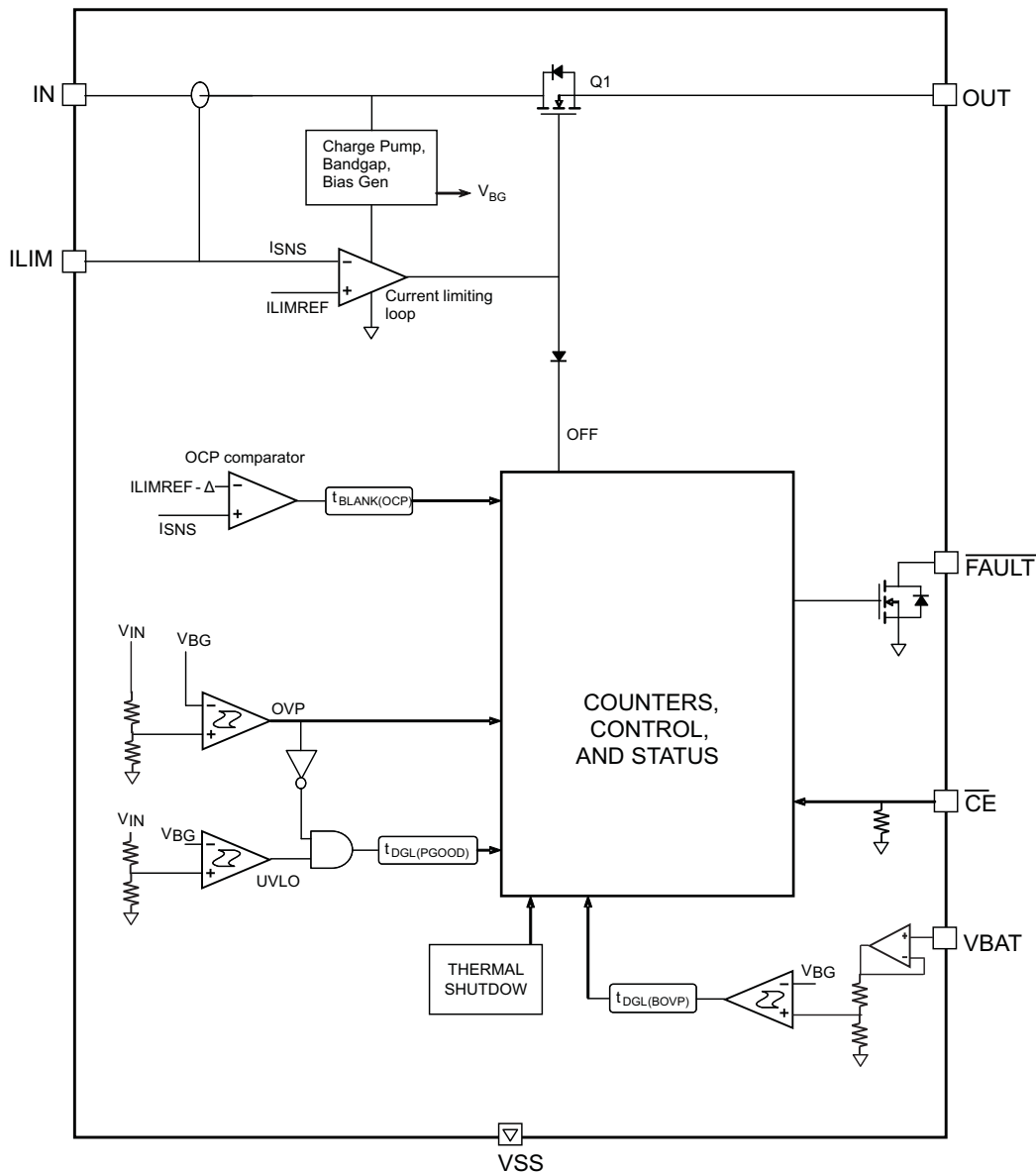

Figure 9. Simplified Block Diagram

## 8.3 Feature Description

### 8.3.1 Power Down

The device remains in power down mode when the voltage at the IN pin is below the undervoltage threshold  $V_{UVLO}$ . The FET Q1 connected between IN and OUT pins is off, and the status output,  $\overline{FAULT}$ , is set to Hi-Z.

### 8.3.2 Power-On Reset

The device resets when the voltage at the IN pin exceeds the UVLO threshold. All internal counters and other circuit blocks are reset. The IC then waits for duration  $t_{DGL(PGOOD)}$  for the input voltage to stabilize. If, after  $t_{DGL(PGOOD)}$ , the input voltage and battery voltage are safe, FET Q1 is turned ON. The IC has a soft-start feature to control the inrush current which minimizes the ringing at input during power up, as shown in [Figure 15](#) (ringing occurs because the parasitic inductance of the adapter cable and the input bypass capacitor form a resonant circuit). Because of the deglitch time at power-on, if the input voltage rises rapidly to beyond the OVP threshold, the device will not switch on at all, instead it will go into protection mode and indicate a fault on the  $\overline{FAULT}$  pin, as shown in [Figure 16](#).

## 8.4 Device Functional Modes

### 8.4.1 Operation

The device continuously monitors the input voltage, input current, and battery voltage as described in detail in the following sections.

#### 8.4.1.1 Input Overvoltage Protection

If the input voltage rises above  $V_{OVP}$ , the internal FET Q1 is turned off, removing power from the circuit. As shown in [Figure 17](#), the response is rapid, with the FET turning off in less than a microsecond. The  $\overline{FAULT}$  pin is driven low. When the input voltage returns below  $V_{OVP} - V_{HYS-OVP}$  (but is still above  $V_{UVLO}$ ), the FET Q1 is turned on again after a deglitch time of  $t_{ON(OVP)}$  to ensure that the input supply has stabilized. [Figure 18](#) shows the recovery from input OVP.

#### 8.4.1.2 Input Overcurrent Protection

If the load current tries to exceed the  $I_{OCP}$  threshold, the device limits the current for a blanking period,  $t_{BLANK(OCP)}$ . If the load current returns to less than  $I_{OCP}$  before  $t_{BLANK(OCP)}$  times out, the device continues to operate. However, if the overcurrent situation persists for  $t_{BLANK(OCP)}$ , the FET Q1 is turned off for a duration of  $t_{REC(OCP)}$ , and the  $\overline{FAULT}$  pin is driven low. The FET is then turned on again after  $t_{REC(OCP)}$  and the current is monitored all over again. Each time an OCP fault occurs, an internal counter is incremented. If 15 OCP faults occur in one charge cycle, the FET is turned off permanently, as shown in [Figure 19](#). The counter is cleared either by removing and re-applying input power, or by disabling and re-enabling the device with the  $\overline{CE}$  pin. [Figure 19](#) and [Figure 20](#) show what happens in an overcurrent fault.

To prevent the input voltage from spiking up due to the inductance of the input cable, Q1 is turned off slowly, resulting in a “soft-stop”, as shown in [Figure 22](#).

#### 8.4.1.3 Battery Overvoltage Protection

The battery overvoltage threshold  $V_{(BOVP)}$  is internally set to 4.35V. If the battery voltage exceeds the  $V_{(BOVP)}$  threshold, the FET Q1 is turned off, and the  $\overline{FAULT}$  pin is driven low. The FET is turned back on once the battery voltage drops to  $V_{(BOVP)} - V_{HYS-BOVP}$  (see [Figure 22](#) and [Figure 23](#)). Each time a battery overvoltage fault occurs, an internal counter is incremented. If 15 such faults occur in one charge cycle, the FET is turned off permanently, as shown in [Figure 23](#). The counter is cleared either by removing and re-applying input power, or by disabling and re-enabling the device with the  $\overline{CE}$  pin. In the case of a battery overvoltage fault, Q1 is switched OFF gradually, resulting in a soft-stop (see [Figure 22](#)).

## Device Functional Modes (continued)

### 8.4.1.4 Thermal Protection

If the junction temperature of the device exceeds  $T_{J(OFF)}$ , the FET Q1 is turned off, and the  $\overline{FAULT}$  pin is driven low. The FET is turned back on when the junction temperature falls below  $T_{J(OFF)} - T_{J(OFF-HYS)}$ .

### 8.4.1.5 Enable Function

The IC has an enable pin which can be used to enable or disable the device. When the  $\overline{CE}$  pin is driven high, the internal FET is turned off. When the  $\overline{CE}$  pin is low, the FET is turned on if other conditions are safe. The OCP counter and the Bat-OVP counter are both reset when the device is disabled and re-enabled. The  $\overline{CE}$  pin has an internal pulldown resistor and can be left floating. Note that the  $\overline{FAULT}$  pin functionality is also disabled when the  $\overline{CE}$  pin is high.

### 8.4.1.6 Fault Indication

The  $\overline{FAULT}$  pin is an active-low open-drain output. It is in a high-impedance state when operating conditions are safe, or when the device is disabled by setting  $\overline{CE}$  high. With  $\overline{CE}$  low, the  $\overline{FAULT}$  pin goes low whenever any of these events occurs:

- Input overvoltage
- Input overcurrent
- Battery overvoltage
- IC Overtemperature

Device Functional Modes (continued)

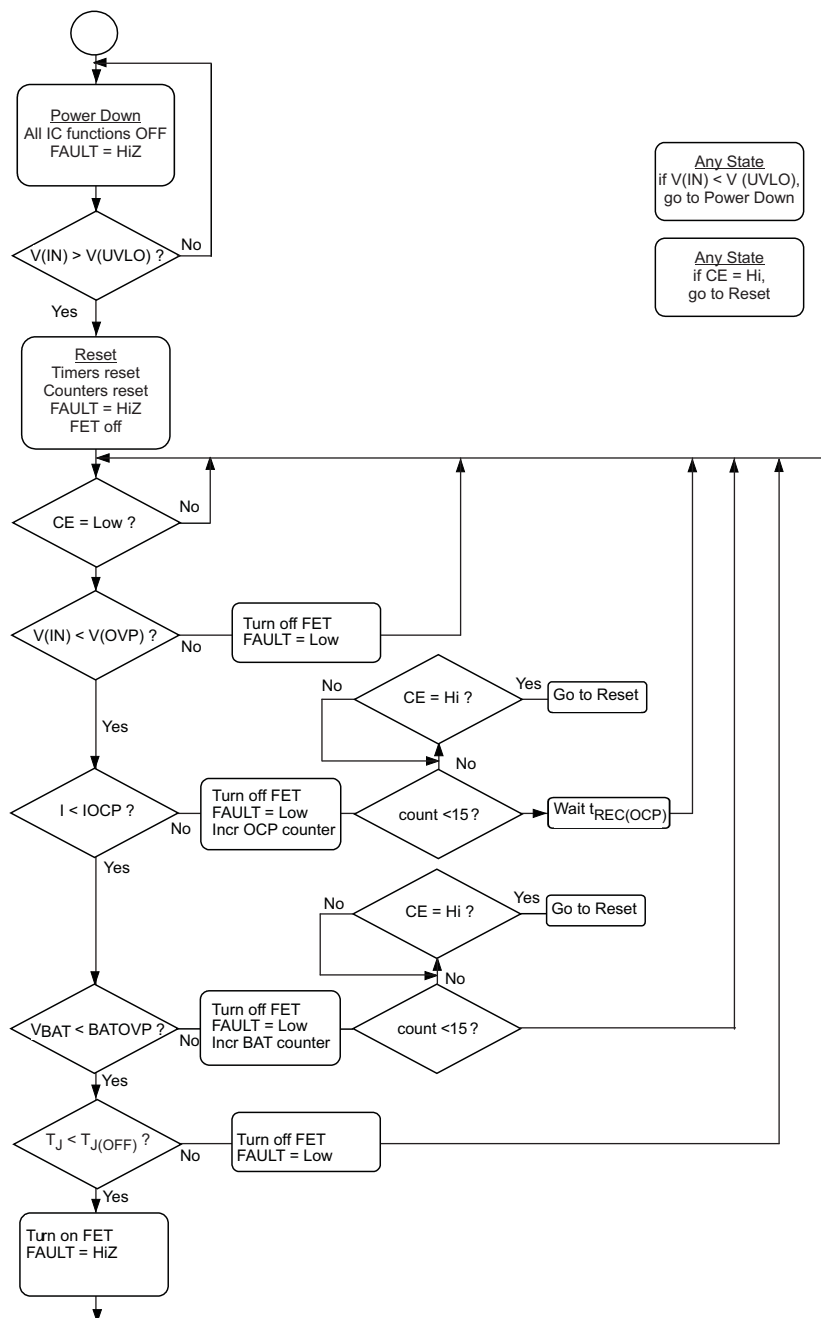
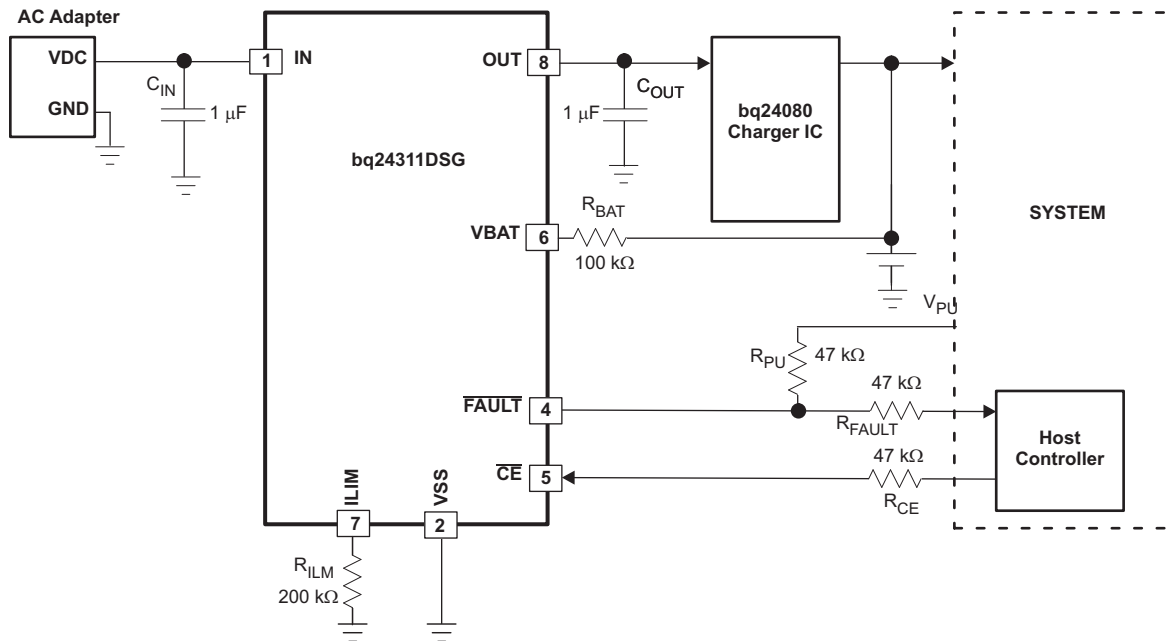

Figure 10. Flow Diagram

## 9 Application and Implementation

### 9.1 Typical Application Circuit

$V_{OVP} = 5.85\text{ V}$ ,  $I_{OCP} = 125\text{ mA}$ ,  $V_{(BOVP)} = 4.35\text{ V}$ .



**Figure 11.**

#### 9.1.1 Design Requirements

##### 9.1.1.1 Selection of $R_{ILIM}$

The overcurrent threshold is programmed by a resistor,  $R_{ILIM}$ , connected from the ILIM pin to VSS. Figure 4 shows the OCP threshold as a function of  $R_{ILIM}$ , and may be approximated by the following equation:

$$I_{OCP} = 25 \div R_{ILIM} \text{ (current in A, resistance in k}\Omega\text{)} \quad (1)$$

Choose a  $I_{OCP}$  between 50 mA and 300 mA and apply the above equation to select a  $R_{ILIM}$  resistor value from 500 k $\Omega$  to 83.3 k $\Omega$  respectively. However, at lower OCP limits, approaching 50 mA, the precision of the current protection circuit decreases the achievable accuracy of the OCP threshold.

##### 9.1.1.2 Selection of $R_{BAT}$

It is strongly recommended that the battery not be tied directly to the VBAT pin of the device, as under some failure modes of the IC, the voltage at the IN pin may appear on the VBAT pin. This voltage can be as high as 30 V, and applying 30 V to the battery in case of the failure of the bq24311 can be hazardous. Connecting the VBAT pin through  $R_{(BAT)}$  prevents a large current from flowing into the battery in case of a failure of the IC. In the interests of safety,  $R_{(BAT)}$  should have a high value. The problem with a large  $R_{(BAT)}$  is that the voltage drop across this resistor because of the VBAT bias current  $I_{(VBAT)}$  causes an error in the  $V_{(BOVP)}$  threshold. This error is over and above the tolerance on the nominal 4.35V  $V_{(BOVP)}$  threshold.

Choosing  $R_{BAT}$  in the range 100 k $\Omega$  to 470 k $\Omega$  is a good compromise. In the case of an IC failure, with  $R_{BAT}$  equal to 100k $\Omega$ , the maximum current flowing into the battery would be  $(30\text{ V} - 3\text{ V}) \div 100\text{ k}\Omega = 246\text{ }\mu\text{A}$ , which is low enough to be absorbed by the bias currents of the system components.  $R_{(BAT)}$  equal to 100 k $\Omega$  would result in a worst-case voltage drop of  $R_{(BAT)} \times I_{(VBAT)} = 1\text{ mV}$ . This is negligible compared to the internal tolerance of 50mV on  $V_{(BOVP)}$  threshold.

If the Bat-OVP function is not required, the VBAT pin should be connected to VSS.

## Typical Application Circuit (continued)

### 9.1.1.3 Selection of $R_{(CE)}$ , $R_{(FAULT)}$ , and $R_{(PU)}$

The  $\overline{CE}$  pin can be used to enable and disable the IC. If host control is not required, the  $\overline{CE}$  pin can be tied to ground or left un-connected, permanently enabling the device.

In applications where external control is required, the  $\overline{CE}$  pin can be controlled by a host processor. As in the case of the VBAT pin (see [Selection of Rbat](#)), the  $\overline{CE}$  pin should be connected to the host GPIO pin through as large a resistor as possible. The limitation on the resistor value is that the minimum  $V_{OH}$  of the host GPIO pin less the drop across the resistor should be greater than  $V_{IH}$  of the bq24311  $\overline{CE}$  pin. The drop across the resistor is given by  $R_{(CE)} \times I_{IH}$ .

The  $\overline{FAULT}$  pin is an open-drain output that goes low during OV, OC, battery-OV, and OT events. If the application does not require monitoring of the  $\overline{FAULT}$  pin, it can be left unconnected. But if the  $\overline{FAULT}$  pin has to be monitored, it should be pulled high externally through  $R_{(PU)}$ , and connected through  $R_{(FAULT)}$  to the host.  $R_{(FAULT)}$  prevents damage to the host controller if the bq24311 fails (see [Selection of Rbat](#)). The resistors should be of high value, in practice values between 22 k $\Omega$  and 100 k $\Omega$  should be sufficient.

### 9.1.1.4 Selection of Input and Output Bypass Capacitors

The input capacitor  $C_{IN}$  in [Figure 11](#) is for decoupling, and serves an important purpose. Whenever there is a step change downwards in the system load current, the inductance of the input cable causes the input voltage to spike up.  $C_{IN}$  prevents the input voltage from overshooting to dangerous levels. It is strongly recommended that a ceramic capacitor of at least 1  $\mu F$  be used at the input of the device. It should be located in close proximity to the IN pin.

$C_{OUT}$  in [Figure 11](#) is also important: If a fast (< 1  $\mu s$  rise time) overvoltage transient occurs at the input, the current that charges  $C_{OUT}$  causes the device's current-limiting loop to kick in, reducing the gate-drive to FET Q1. This results in improved performance for input overvoltage protection.  $C_{OUT}$  should also be a ceramic capacitor of at least 1  $\mu F$ , located close to the OUT pin.  $C_{OUT}$  also serves as the input decoupling capacitor for the charging circuit downstream of the protection IC.

## 9.1.2 Detailed Design Procedures

### 9.1.2.1 Powering Accessories

In some applications, the equipment that the protection IC resides in may be required to provide power to an accessory (that is, a cellphone may power a headset or an external memory card) through the same connector pins that are used by the adapter for charging. [Figure 12](#) and [Figure 13](#) illustrate typical charging and accessory-powering scenarios:

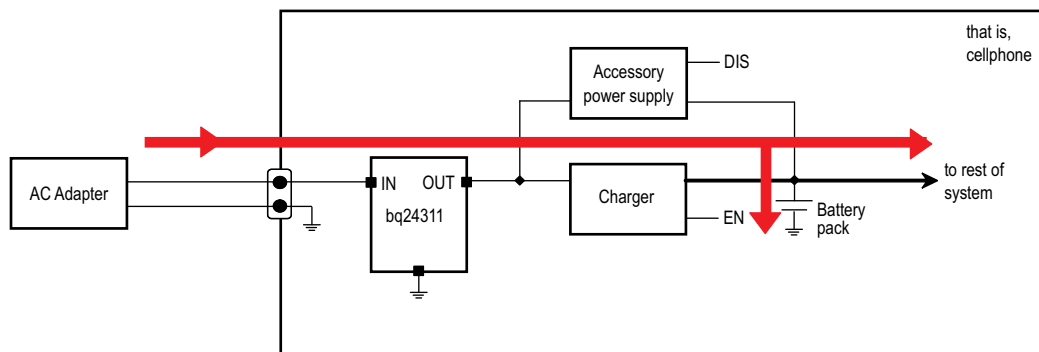

Figure 12. Charging - The Red Arrows Show the Direction of Current Flow

Typical Application Circuit (continued)

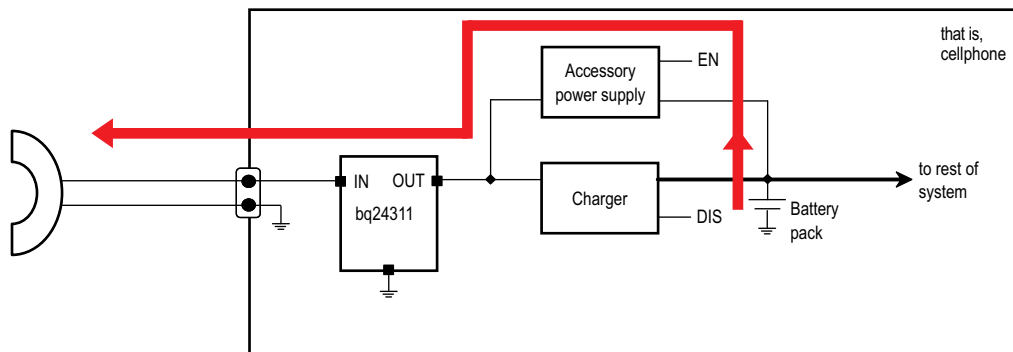

Figure 13. Powering an Accessory - The Red Arrows Show the Direction of Current Flow

In the second case, when power is being delivered to an accessory, the bq24311 device is required to support current flow from the OUT pin to the IN pin.

If  $V_{OUT} > V_{(UVLO)} + 0.7 \text{ V}$ , FET Q1 is turned on, and the reverse current does not flow through the diode but through Q1. Q1 will then remain ON as long as  $V_{OUT} > V_{(UVLO)} - V_{(HYS-UVLO)} + R_{DS(on)} \times I_{(ACCESSORY)}$ . Within this voltage range, the reverse current capability is the same as the forward capability, 0.5 A. It should be noted that there is no overcurrent protection in this direction.

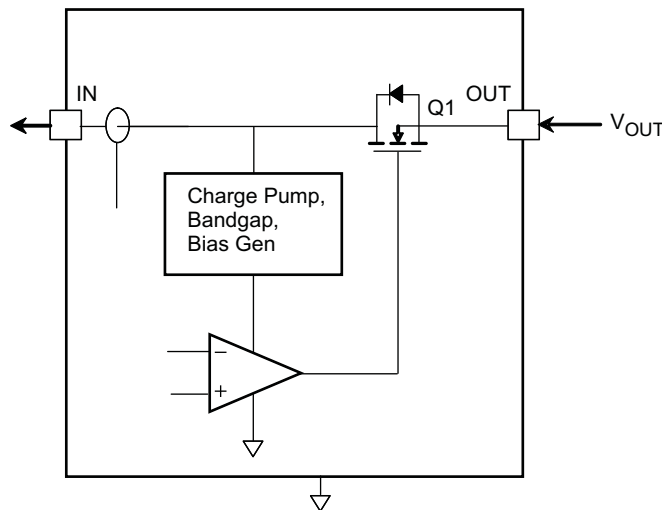

Figure 14.

Typical Application Circuit (continued)

9.1.3 Application Curves

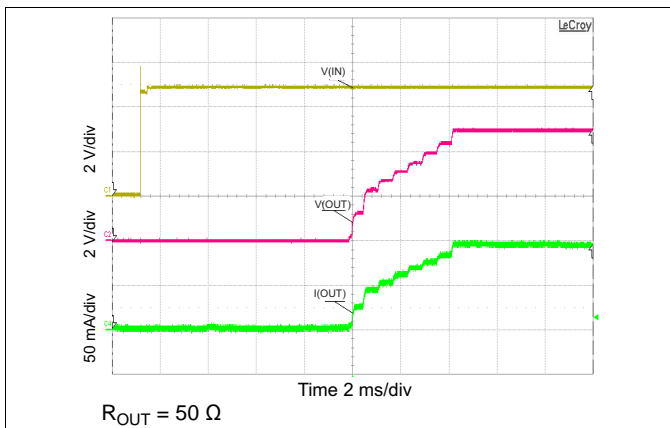

Figure 15. Normal Power-On Showing Soft-Start

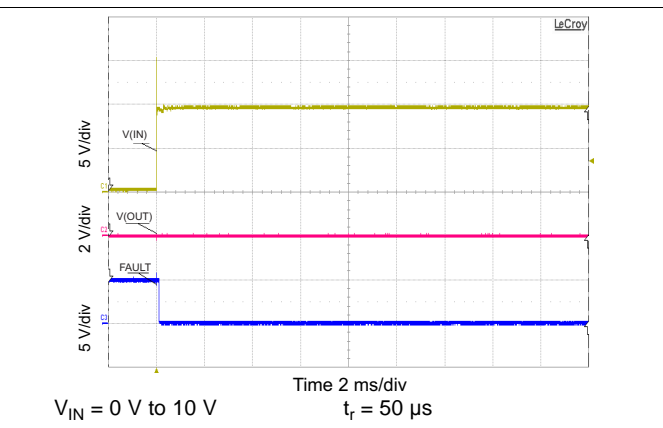

Figure 16. OVP at Power-On

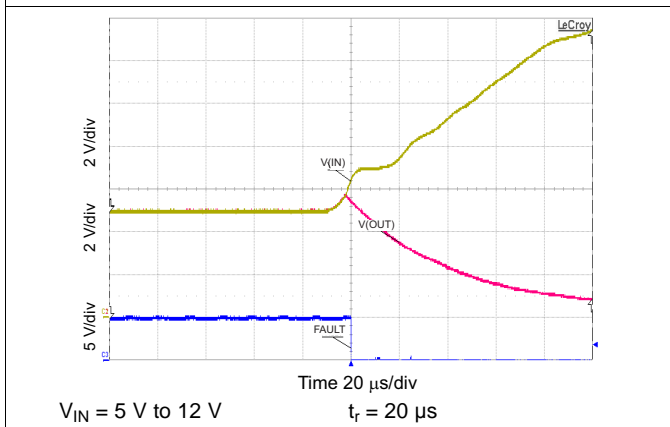

Figure 17. OVP Response for Input Step

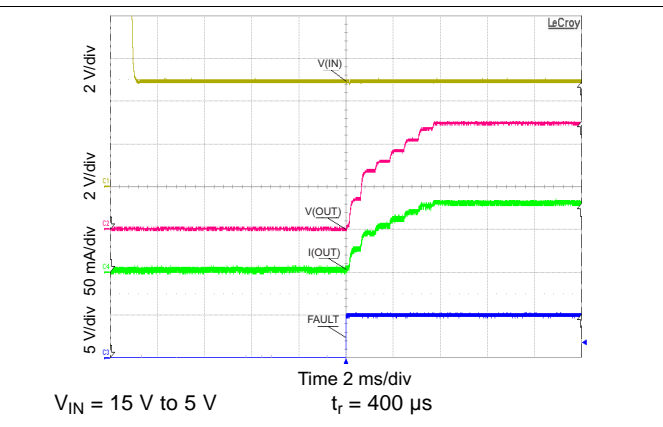

Figure 18. Recovery from OVP

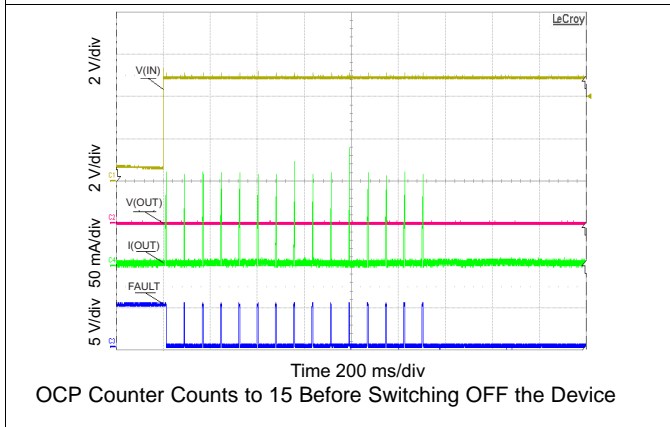

Figure 19. OCP, Powering Up into a Short Circuit on OUT Pin

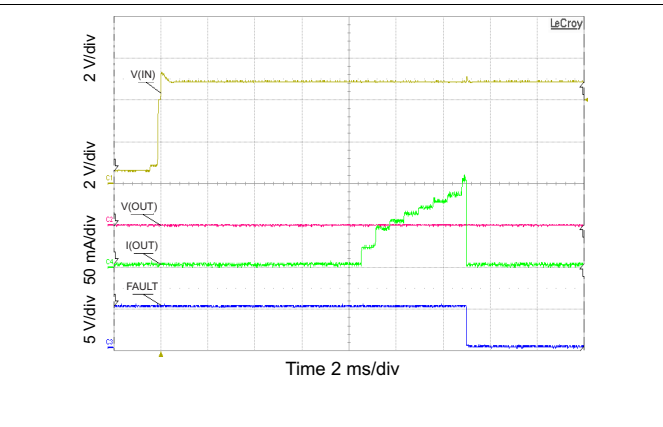
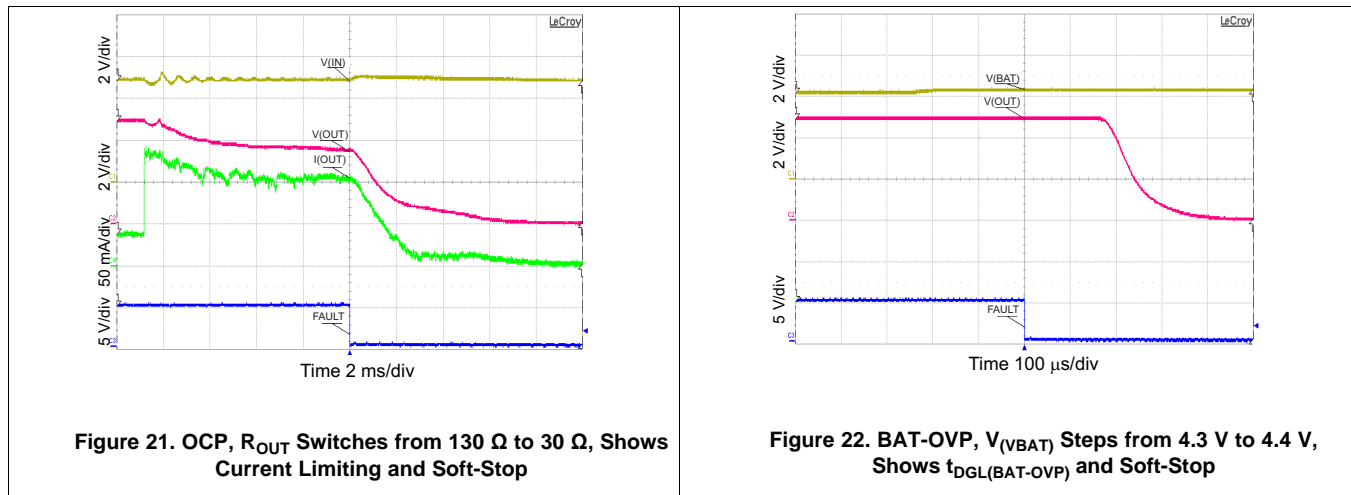

Figure 20. OCP, Zoom-in on the First Cycle of Figure 19

### Typical Application Circuit (continued)



**Figure 21. OCP, R<sub>OUT</sub> Switches from 130 Ω to 30 Ω, Shows Current Limiting and Soft-Stop**

**Figure 22. BAT-OVP, V<sub>(VBAT)</sub> Steps from 4.3 V to 4.4 V, Shows t<sub>DGL(BAT-OVP)</sub> and Soft-Stop**

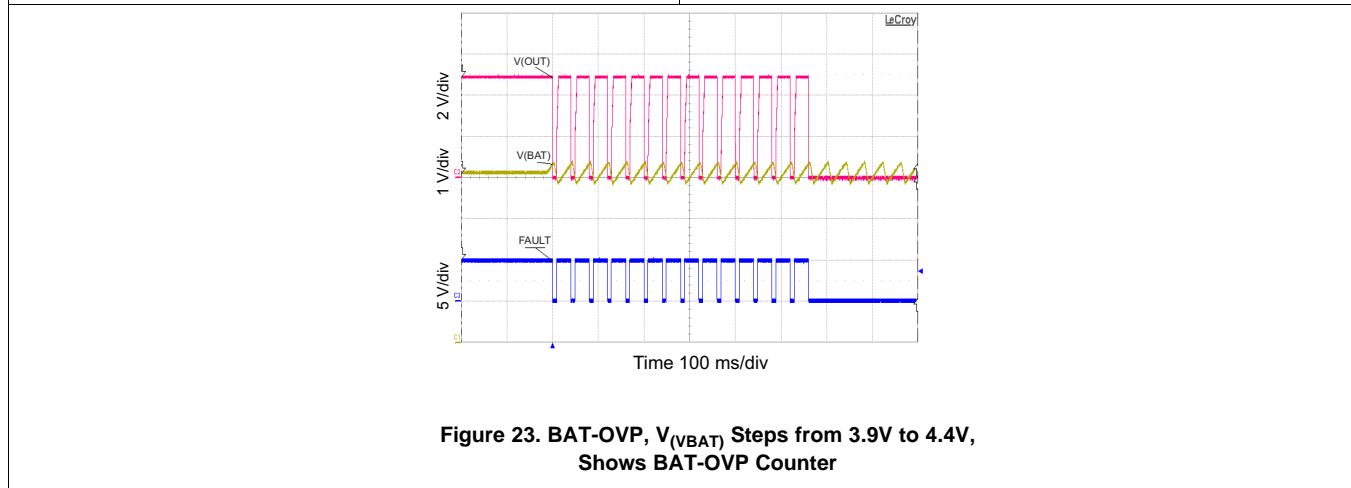

**Figure 23. BAT-OVP, V<sub>(VBAT)</sub> Steps from 3.9V to 4.4V, Shows BAT-OVP Counter**

## 10 Power Supply Requirements

In a typical application, the system is powered by a USB port or USB wall adapter.

The minimum input voltage, where the protector starts to pass current assuming V<sub>BAT</sub> is acceptable, could be 2.7 V. The maximum supported input voltage is up to 5.85 V; the overvoltage protection kicks in at 5.85 V and the maximum input voltage rating is 30 V input rating.

## 11 Layout

### 11.1 Layout Guidelines

- This device is a protection device, and is meant to protect down-stream circuitry from hazardous voltages. Potentially, high voltages may be applied to this IC. It has to be ensured that the edge-to-edge clearances of PCB traces satisfy the design rules for high voltages.
- The device uses SON packages with a PowerPAD™. For good thermal performance, the PowerPAD should be thermally coupled with the PCB ground plane. In most applications, this will require a copper pad directly under the IC. This copper pad should be connected to the ground plane with an array of thermal vias.
- $C_{IN}$  and  $C_{OUT}$  should be located close to the IC. Other components like  $R_{ILIM}$  and  $R_{BAT}$  should also be located close to the IC.

### 11.2 Layout Example

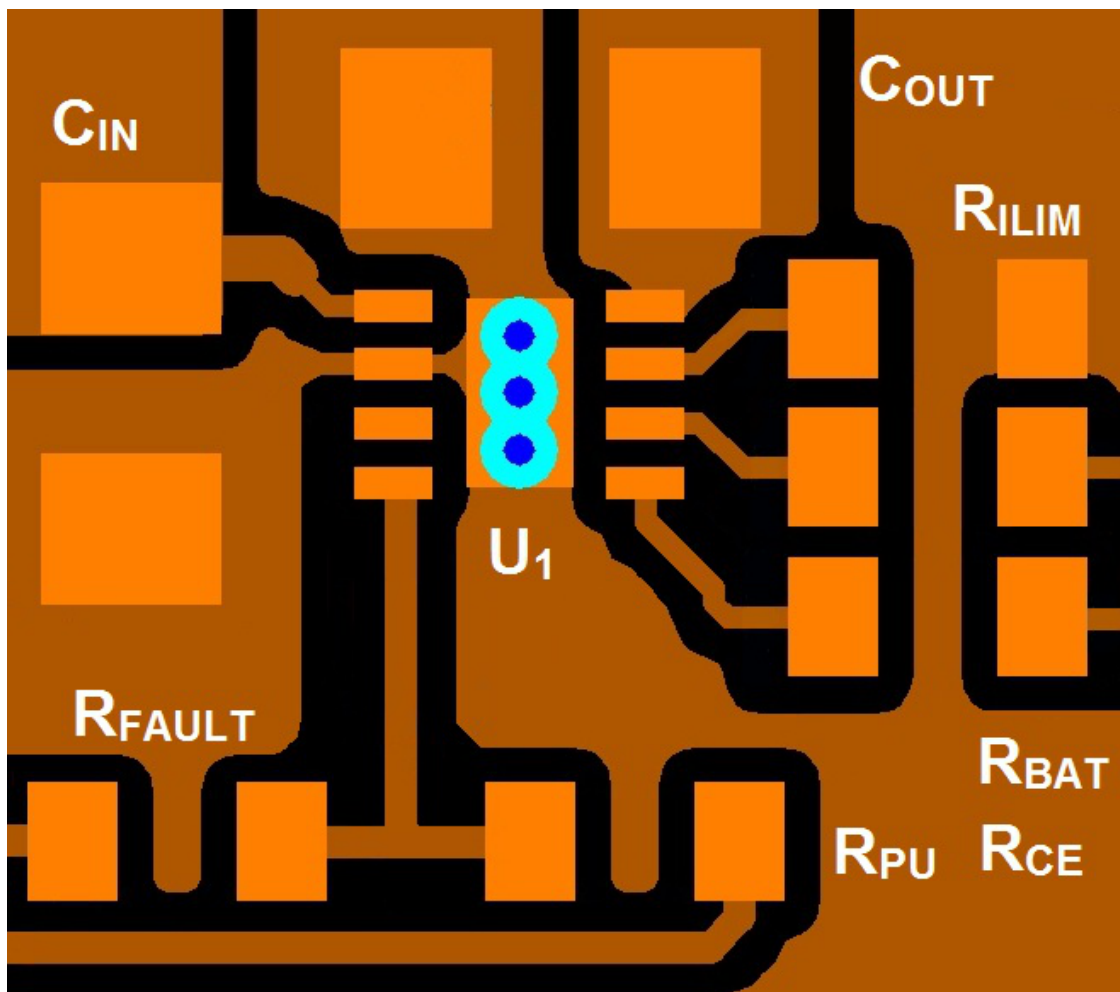

## 12 Device and Documentation Support

### 12.1 Trademarks

PowerPAD is a trademark of Texas Instruments.

Bluetooth is a trademark of Bluetooth SIG, Inc.

### 12.2 Electrostatic Discharge Caution



These devices have limited built-in ESD protection. The leads should be shorted together or the device placed in conductive foam during storage or handling to prevent electrostatic damage to the MOS gates.

### 12.3 Glossary

[SLYZ022](#) — *TI Glossary*.

This glossary lists and explains terms, acronyms, and definitions.

## 13 Mechanical, Packaging, and Orderable Information

The following pages include mechanical packaging and orderable information. This information is the most current data available for the designated devices. This data is subject to change without notice and revision of this document. For browser-based versions of this data sheet, refer to the left-hand navigation.

**PACKAGING INFORMATION**

Orderable Device	Status (1)	Package Type	Package Drawing	Pins	Package Qty	Eco Plan (2)	Lead/Ball Finish (6)	MSL Peak Temp (3)	Op Temp (°C)	Device Marking (4/5)	Samples
BQ24311DSGR	ACTIVE	WSO	DSG	8	3000	Green (RoHS & no Sb/Br)	NIPDAU	Level-2-260C-1 YEAR	-40 to 85	SHN	<a href="#">Samples</a>
BQ24311DSGT	ACTIVE	WSO	DSG	8	250	Green (RoHS & no Sb/Br)	NIPDAU	Level-2-260C-1 YEAR		SHN	<a href="#">Samples</a>

(1) The marketing status values are defined as follows:

**ACTIVE:** Product device recommended for new designs.

**LIFEBUY:** TI has announced that the device will be discontinued, and a lifetime-buy period is in effect.

**NRND:** Not recommended for new designs. Device is in production to support existing customers, but TI does not recommend using this part in a new design.

**PREVIEW:** Device has been announced but is not in production. Samples may or may not be available.

**OBsolete:** TI has discontinued the production of the device.

(2) **RoHS:** TI defines "RoHS" to mean semiconductor products that are compliant with the current EU RoHS requirements for all 10 RoHS substances, including the requirement that RoHS substance do not exceed 0.1% by weight in homogeneous materials. Where designed to be soldered at high temperatures, "RoHS" products are suitable for use in specified lead-free processes. TI may reference these types of products as "Pb-Free".

**RoHS Exempt:** TI defines "RoHS Exempt" to mean products that contain lead but are compliant with EU RoHS pursuant to a specific EU RoHS exemption.

**Green:** TI defines "Green" to mean the content of Chlorine (Cl) and Bromine (Br) based flame retardants meet JS709B low halogen requirements of <=1000ppm threshold. Antimony trioxide based flame retardants must also meet the <=1000ppm threshold requirement.

(3) MSL, Peak Temp. - The Moisture Sensitivity Level rating according to the JEDEC industry standard classifications, and peak solder temperature.

(4) There may be additional marking, which relates to the logo, the lot trace code information, or the environmental category on the device.

(5) Multiple Device Markings will be inside parentheses. Only one Device Marking contained in parentheses and separated by a "-" will appear on a device. If a line is indented then it is a continuation of the previous line and the two combined represent the entire Device Marking for that device.

(6) Lead/Ball Finish - Orderable Devices may have multiple material finish options. Finish options are separated by a vertical ruled line. Lead/Ball Finish values may wrap to two lines if the finish value exceeds the maximum column width.

**Important Information and Disclaimer:**The information provided on this page represents TI's knowledge and belief as of the date that it is provided. TI bases its knowledge and belief on information provided by third parties, and makes no representation or warranty as to the accuracy of such information. Efforts are underway to better integrate information from third parties. TI has taken and continues to take reasonable steps to provide representative and accurate information but may not have conducted destructive testing or chemical analysis on incoming materials and chemicals. TI and TI suppliers consider certain information to be proprietary, and thus CAS numbers and other limited information may not be available for release.

In no event shall TI's liability arising out of such information exceed the total purchase price of the TI part(s) at issue in this document sold by TI to Customer on an annual basis.



## TAPE AND REEL INFORMATION



### QUADRANT ASSIGNMENTS FOR PIN 1 ORIENTATION IN TAPE



\*All dimensions are nominal

Device	Package Type	Package Drawing	Pins	SPQ	Reel Diameter (mm)	Reel Width W1 (mm)	A0 (mm)	B0 (mm)	K0 (mm)	P1 (mm)	W (mm)	Pin1 Quadrant
BQ24311DSGR	WSON	DSG	8	3000	180.0	8.4	2.3	2.3	1.15	4.0	8.0	Q2
BQ24311DSGT	WSON	DSG	8	250	180.0	8.4	2.3	2.3	1.15	4.0	8.0	Q2

**TAPE AND REEL BOX DIMENSIONS**

\*All dimensions are nominal

Device	Package Type	Package Drawing	Pins	SPQ	Length (mm)	Width (mm)	Height (mm)
BQ24311DSGR	WSON	DSG	8	3000	210.0	185.0	35.0
BQ24311DSGT	WSON	DSG	8	250	210.0	185.0	35.0

## GENERIC PACKAGE VIEW

**DSG 8**

**WSON - 0.8 mm max height**

2 x 2, 0.5 mm pitch

PLASTIC SMALL OUTLINE - NO LEAD

This image is a representation of the package family, actual package may vary.  
Refer to the product data sheet for package details.

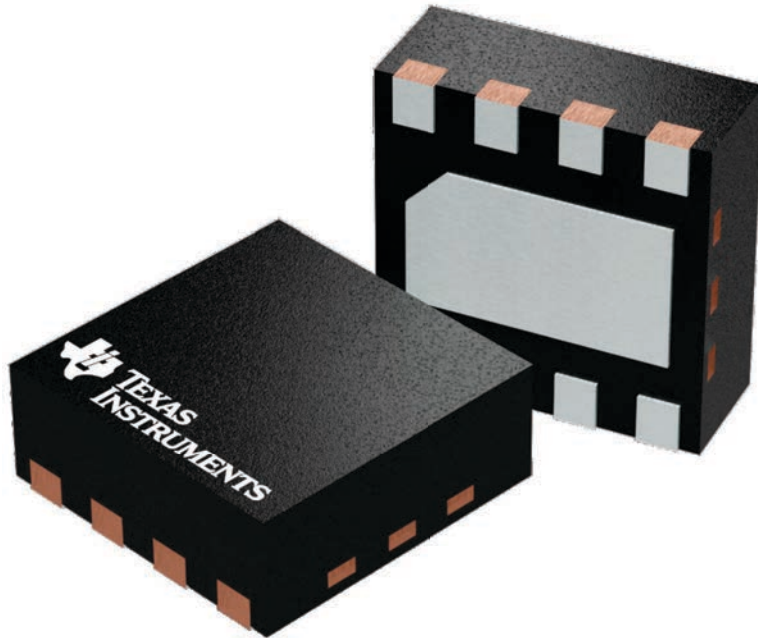

4224783/A

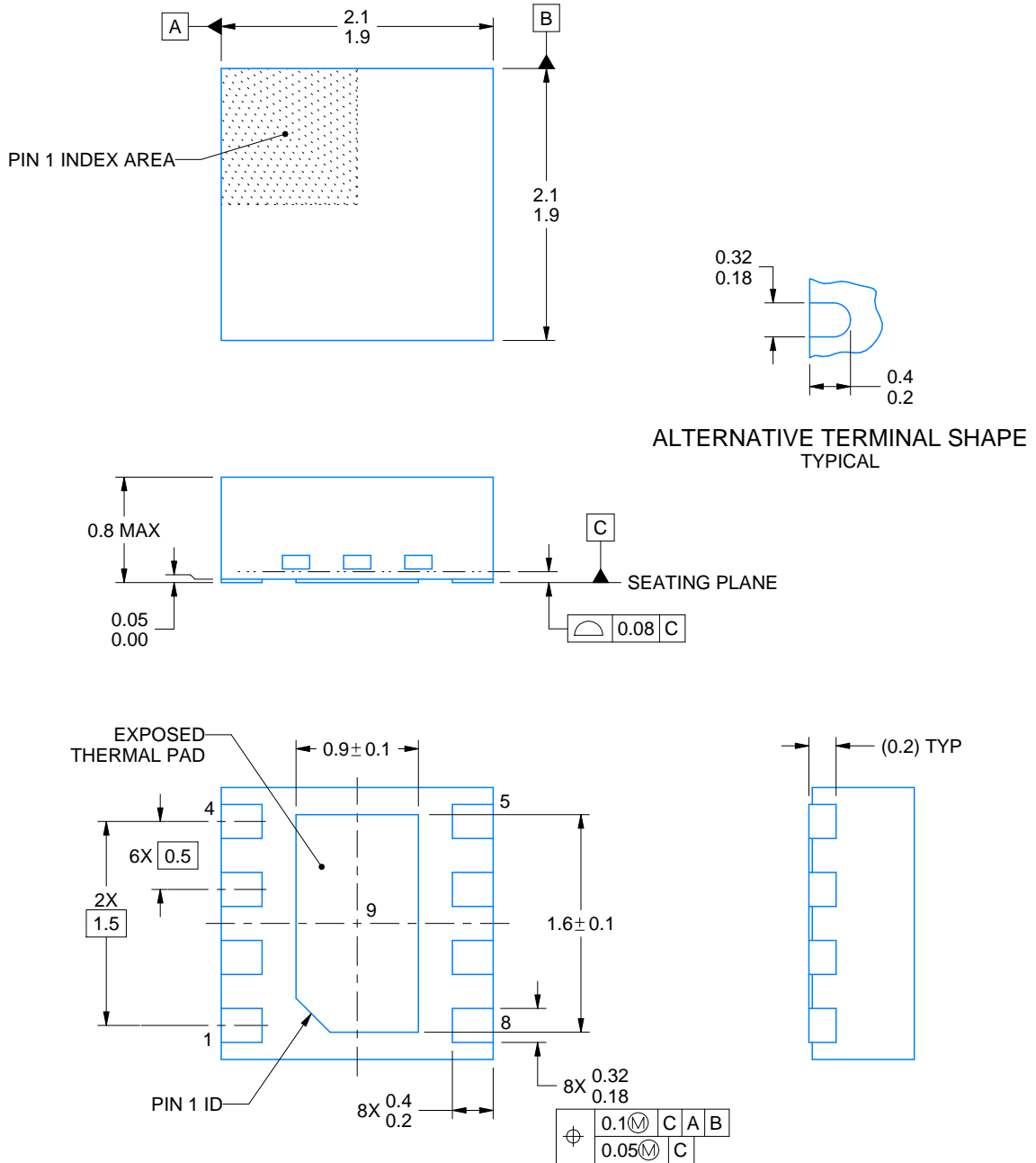
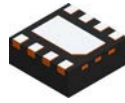

4218900/D 04/2020

NOTES:

1. All linear dimensions are in millimeters. Any dimensions in parenthesis are for reference only. Dimensioning and tolerancing per ASME Y14.5M.
2. This drawing is subject to change without notice.
3. The package thermal pad must be soldered to the printed circuit board for thermal and mechanical performance.

# EXAMPLE BOARD LAYOUT

DSG0008A

WSON - 0.8 mm max height

PLASTIC SMALL OUTLINE - NO LEAD

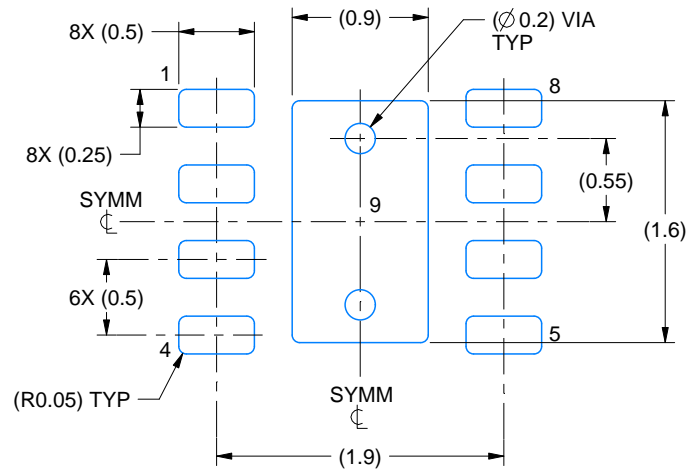

LAND PATTERN EXAMPLE  
SCALE:20X

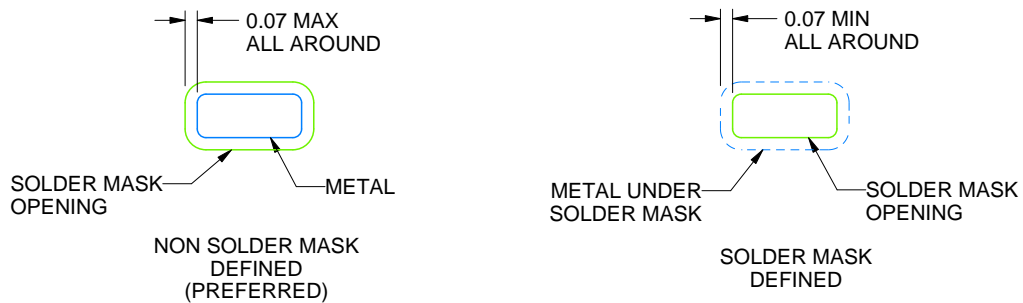

SOLDER MASK DETAILS

4218900/D 04/2020

NOTES: (continued)

4. This package is designed to be soldered to a thermal pad on the board. For more information, see Texas Instruments literature number SLUA271 ([www.ti.com/lit/sluea271](http://www.ti.com/lit/sluea271)).
5. Vias are optional depending on application, refer to device data sheet. If any vias are implemented, refer to their locations shown on this view. It is recommended that vias under paste be filled, plugged or tented.

# EXAMPLE STENCIL DESIGN

DSG0008A

WSON - 0.8 mm max height

PLASTIC SMALL OUTLINE - NO LEAD

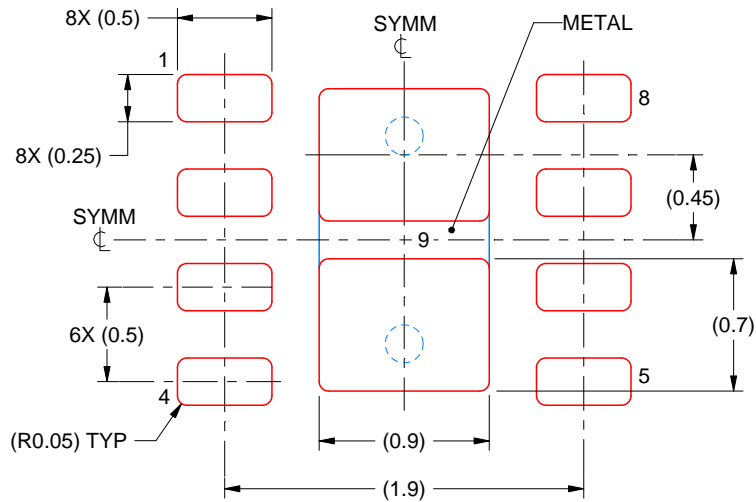

SOLDER PASTE EXAMPLE  
BASED ON 0.125 mm THICK STENCIL

EXPOSED PAD 9:  
87% PRINTED SOLDER COVERAGE BY AREA UNDER PACKAGE  
SCALE:25X

4218900/D 04/2020

NOTES: (continued)

6. Laser cutting apertures with trapezoidal walls and rounded corners may offer better paste release. IPC-7525 may have alternate design recommendations.

## IMPORTANT NOTICE AND DISCLAIMER

TI PROVIDES TECHNICAL AND RELIABILITY DATA (INCLUDING DATASHEETS), DESIGN RESOURCES (INCLUDING REFERENCE DESIGNS), APPLICATION OR OTHER DESIGN ADVICE, WEB TOOLS, SAFETY INFORMATION, AND OTHER RESOURCES "AS IS" AND WITH ALL FAULTS, AND DISCLAIMS ALL WARRANTIES, EXPRESS AND IMPLIED, INCLUDING WITHOUT LIMITATION ANY IMPLIED WARRANTIES OF MERCHANTABILITY, FITNESS FOR A PARTICULAR PURPOSE OR NON-INFRINGEMENT OF THIRD PARTY INTELLECTUAL PROPERTY RIGHTS.

These resources are intended for skilled developers designing with TI products. You are solely responsible for (1) selecting the appropriate TI products for your application, (2) designing, validating and testing your application, and (3) ensuring your application meets applicable standards, and any other safety, security, or other requirements. These resources are subject to change without notice. TI grants you permission to use these resources only for development of an application that uses the TI products described in the resource. Other reproduction and display of these resources is prohibited. No license is granted to any other TI intellectual property right or to any third party intellectual property right. TI disclaims responsibility for, and you will fully indemnify TI and its representatives against, any claims, damages, costs, losses, and liabilities arising out of your use of these resources.

TI's products are provided subject to TI's Terms of Sale ([www.ti.com/legal/termsofsale.html](http://www.ti.com/legal/termsofsale.html)) or other applicable terms available either on [ti.com](http://ti.com) or provided in conjunction with such TI products. TI's provision of these resources does not expand or otherwise alter TI's applicable warranties or warranty disclaimers for TI products.

Mailing Address: Texas Instruments, Post Office Box 655303, Dallas, Texas 75265  
Copyright © 2020, Texas Instruments Incorporated