

## NexFET™ Smart Synchronous Rectifier

### FEATURES

- Typical  $R_{on}$  of 0.55 m $\Omega$  at 4.5 V<sub>DD</sub>
- Integrated FET Driver
- Max Rated Current 80A
- High Density – SON 5-mm × 6-mm Footprint
- Ultra Low Inductance Package
- System Optimized PCB Footprint
- TTL IN signal Compatible
- Halogen Free
- RoHS Compliant – Lead Free Terminal Plating  
Halogen Free

### APPLICATIONS

- Secondary Synchronous Rectification for DC/DC Converters

### DESCRIPTION

The CSD43301Q5M NexFET™ Smart Synchronous Rectifier is a highly optimized design for secondary synchronous rectification in a high power high density DC/DC converter. This product integrates the driver IC and an ultra low  $R_{on}$  Power MOSFET to complete the synchronous rectification function. In addition, the PCB footprint has been optimized to help reduce design time and simplify the completion of the overall system design.

### ORDERING INFORMATION

Device	Package	Media	Qty	Ship
CSD43301Q5M	SON 5-mm × 6-mm Plastic Package	13-Inch Reel	2500	Tape and Reel

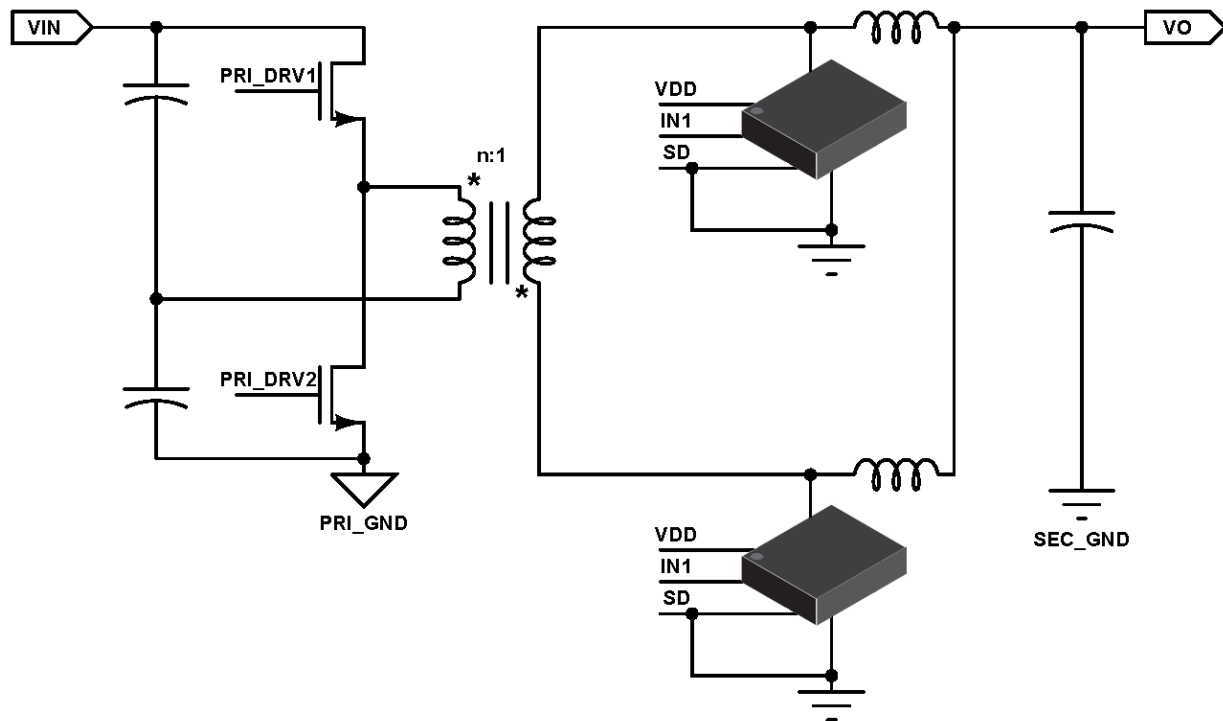

Figure 1. Application Diagram



Please be aware that an important notice concerning availability, standard warranty, and use in critical applications of Texas Instruments semiconductor products and disclaimers thereto appears at the end of this data sheet.

NexFET is a trademark of Texas Instruments.

# CSD43301Q5M

SLPS380B – DECEMBER 2012 – REVISED MAY 2013

www.ti.com



These devices have limited built-in ESD protection. The leads should be shorted together or the device placed in conductive foam during storage or handling to prevent electrostatic damage to the MOS gates.

## ABSOLUTE MAXIMUM RATINGS<sup>(1)</sup>

T<sub>A</sub> = 25°C (unless otherwise noted)

	VALUE		UNIT	
	MIN	MAX		
DRAIN to P <sub>GND</sub>	-0.3	12	V	
DRAIN to P <sub>GND</sub> (10ns)	-7	14	V	
V <sub>DD</sub> to P <sub>GND</sub>	-0.3	8	V	
IN, SD to P <sub>GND</sub> <sup>(2)</sup>	-0.3	V <sub>DD</sub> + 0.3	V	
ESD Rating	Human Body Model (HBM)		2000	V
	Charged Device Model (CDM)		500	V
Power Dissipation (P <sub>D</sub> )		12	W	
Operating Temperature Range, (T <sub>J</sub> )	-40	150	°C	
Storage Temperature Range, (T <sub>STG</sub> )	-65	150	°C	

- (1) Stresses above those listed in "Absolute Maximum Ratings" may cause permanent damage to the device. These are stress ratings only and functional operation of the device at these or any other conditions beyond those indicated under "Recommended Operating Conditions" is not implied. Exposure to Absolute Maximum rated conditions for extended periods may affect device reliability.
- (2) Must not exceed 8V

## RECOMMENDED OPERATING CONDITIONS

T<sub>A</sub> = 25° (unless otherwise noted)

Parameter	Conditions	MIN	MAX	UNIT
Bias Voltage (V <sub>DD</sub> )		4.5	6	V
Input Supply Voltage (V <sub>IN</sub> )			9.6	V
Continuous Output Current (I <sub>OUT</sub> )			80	A
Peak Output Current, (I <sub>OUT-PK</sub> ) <sup>(1)</sup>			120	A
Switching Frequency, (f <sub>SW</sub> )			1500	kHz
Minimum IN Pulse Width		48		ns
Operating Temperature		-40	125	°C

- (1) Peak Output Current is applied for t<sub>p</sub> = 50µs.

## THERMAL INFORMATION

T<sub>A</sub> = 25°C (unless otherwise noted)

PARAMETER		MIN	TYP	MAX	UNIT
R <sub>θJC</sub>	Thermal Resistance, Junction-to-Case (Top of package)			20	°C/W
R <sub>θJB</sub>	Thermal Resistance, Junction-to-Board <sup>(1)</sup>			2	°C/W

- (1) R<sub>θJB</sub> value based on hottest board temperature within 1mm of the package.

**ELECTRICAL CHARACTERISTICS**
 $T_A = 25^\circ\text{C}$ ,  $V_{DD} = 5\text{V}$  (unless otherwise noted)

PARAMETER	CONDITIONS	MIN	TYP	MAX	UNIT
<b>Device On Resistance</b>					
$R_{on}$	$I_D = 50\text{A}$ , $T_J = 25^\circ\text{C}$	0.55	0.70		m $\Omega$
	$I_D = 50\text{A}$ , $T_J = 125^\circ\text{C}$	0.70	0.88		m $\Omega$
<b><math>V_{DD}</math></b>					
Standby Supply Current ( $I_{DD}$ )	$SD = V_{DD} = 5\text{V}$	153	300		$\mu\text{A}$
Operating Supply Current ( $I_{DD}$ )	$SD = 0\text{V}$ , $IN = 50\%$ Duty Cycle, $f_{sw} = 300\text{kHz}$	29.5			mA
<b>POWER-ON RESET AND UNDER VOLTAGE LOCKOUT</b>					
Power on Reset ( $V_{DD}$ Rising)	$T_A = 25^\circ\text{C}$	3.9	4.2	4.5	V
	$T_A = -40^\circ\text{C}$ to $140^\circ\text{C}$	3.7	4.2	4.65	V
UVLO ( $V_{DD}$ Falling)		3.45	3.9	4.35	V
Hysteresis		200	300	500	mV
<b>IN</b>					
IN Logic Level High ( $V_{INH}$ )	$V_{DD} = 5\text{V}$ , $SD = 0$ , $I_D = 25\text{A}$ (See <a href="#">Figure 4</a> )	2.0			V
IN Logic Level Low ( $V_{INL}$ )				0.8	V
IN Input Hysteresis			0.8		V
IN to DRAIN Propagation Delay ( $t_{PDLH}$ )				32	ns
IN to DRAIN Propagation Delay ( $t_{PDHL}$ )				80	ns
Minimum Pulse Width Changes Output				36	48
<b>SD</b>					
SD Logic Level High Threshold ( $V_{IH}$ )		2.0			V
SD Logic Level Low Threshold ( $V_{IL}$ )				0.8	V
Hysteresis			0.8		V
SD to DRAIN Propagation Delay ( $t_{PDLH}$ )	$V_{DD} = 5\text{V}$ , $IN = V_{DD}$ , $I_D = 25\text{A}$ (See <a href="#">Figure 5</a> )		80		ns
SD to DRAIN Propagation Delay ( $t_{PDHL}$ )				32	ns
<b>Dynamic Characteristics</b>					
Output Capacitance ( $C_O$ )	$V_{DRAIN} = 6\text{V}$		10	13	nF
Output Charge ( $Q_O$ )			54		nC
<b>Body Diode</b>					
Forward Voltage ( $V_F$ )	$I_D = 40\text{A}$	0.75	0.85		V
Reverse Recovery Charge ( $Q_{RR}$ )	$I_D = 40\text{A}$ , $V_{DRAIN} = 6\text{V}$ , $di/dt = 150\text{A}/\mu\text{s}$		161		nC
Reverse Recovery Time Delay ( $t_{RR}$ )				72	ns

### PIN CONFIGURATION

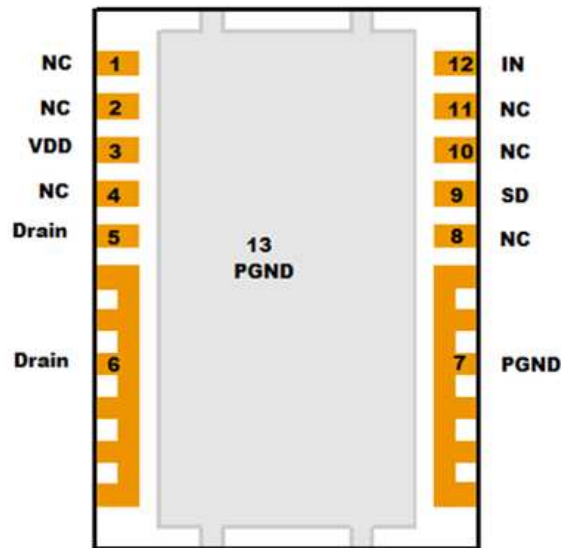

Figure 2. Pin Configuration

### PIN DESCRIPTION

PIN		DESCRIPTION
NO.	NAME	
1,2,4, 8, 10,11	NC	No connect. These should not be used for any electrical connection. These pins should not be connected to each other. Connect to dead copper only.
3	V <sub>DD</sub>	Supply Voltage for IC
5,6	DRAIN	Drain terminal of internal MOSFET
7	P <sub>GND</sub>	Power Ground and source terminal of the internal MOSFET. Needs to be connected to Pin 13 on PCB
9	SD	Shut Down Pin: Logic High disables the Device
12	IN	Input for Gate Driver
13	P <sub>GND</sub>	Power Ground and source terminal of the internal MOSFET. Needs to be connected to Pin 7 on PCB

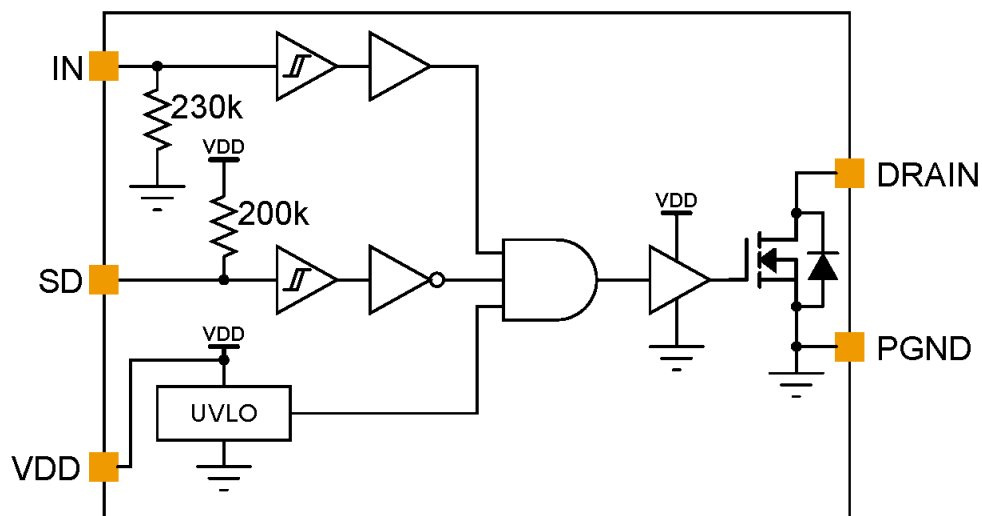

Figure 3. Functional Block Diagram

TYPICAL DEVICE CHARACTERISTICS

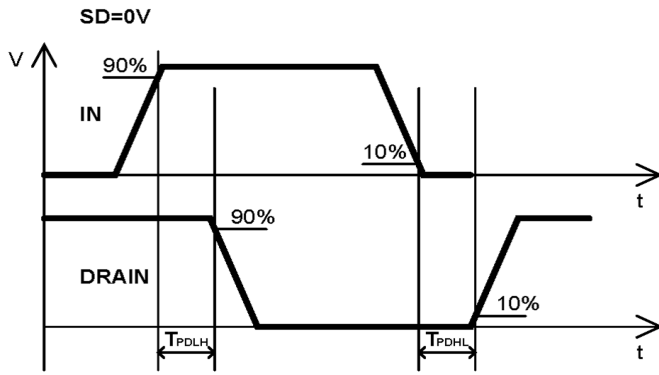

Figure 4. IN Switching Waveforms

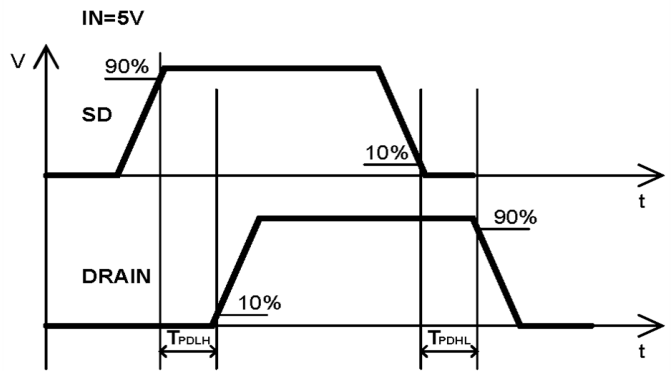

Figure 5. SD Switching Waveform

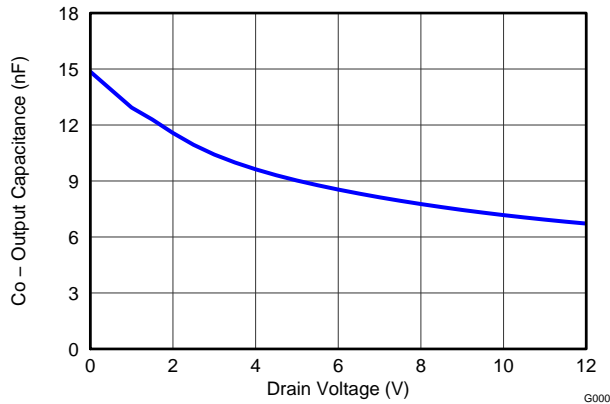

Figure 6. Output Capacitance

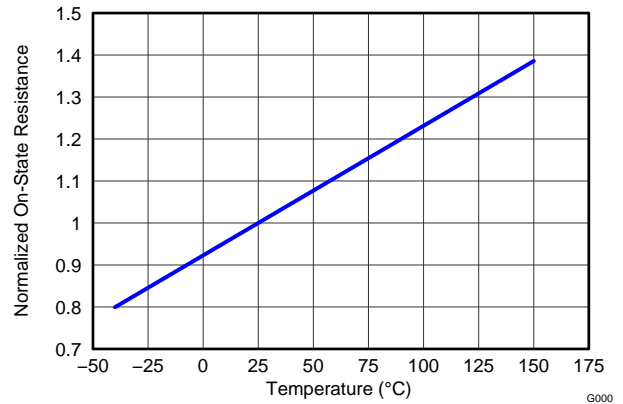

Figure 7. Normalized On Resistance  $R_{on}$

TYPICAL DEVICE CHARACTERISTICS CONTINUED

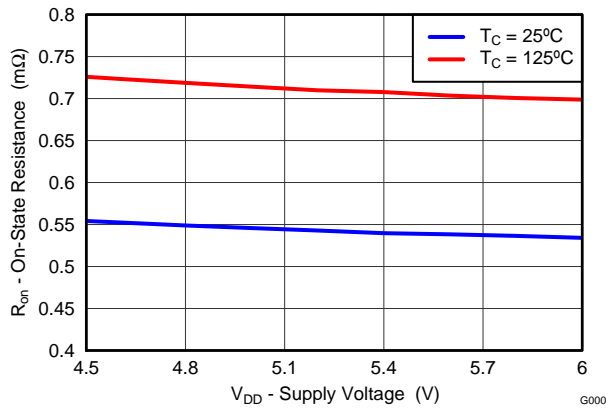

Figure 8. On Resistance vs. Supply Voltage

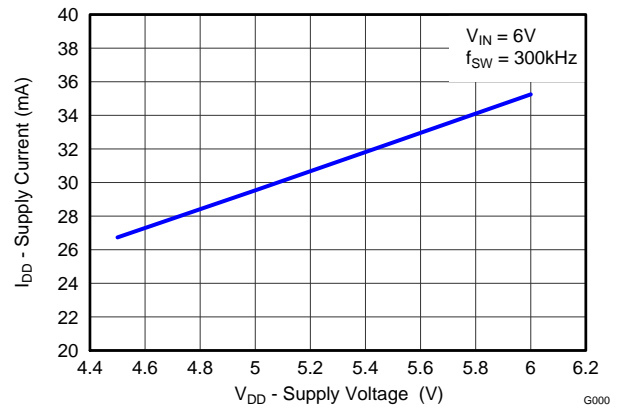

Figure 9. Supply Current vs. Supply Voltage

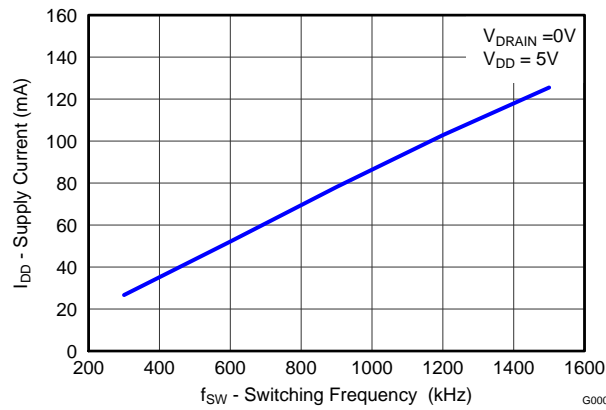

Figure 10. Supply Current vs. Switching Frequency

## Application Information

### $V_{DD}$ and Under-Voltage Lockout (UVLO)

The driver IC in the CSD43301Q5M has an internal UVLO protection feature on the  $V_{DD}$  pin. Whenever the driver is in the UVLO condition (i.e. when  $V_{DD}$  voltage is less than  $V_{ON}$  during power up and when  $V_{DD}$  voltage is less than  $V_{OFF}$  during power down), this circuit holds the gate of the integrated MOSFET LOW, regardless of the status of IN and SD. The UVLO is typically 4.2V with 300-mV typical hysteresis. This hysteresis helps prevent chatter when low  $V_{DD}$  supply voltages have noise from the power supply and also when there are droops in the  $V_{DD}$  bias voltage when the system commences switching and there is a sudden increase in  $I_{DD}$ . This provides the capability to operate at low voltage levels (below 5V), along with best-in-class switching characteristics. For example, at power up, the MOSFET remains OFF until the  $V_{DD}$  voltages reaches the UVLO threshold. This prevents operating the MOSFET in the linear region and conducting a large load current at the same time, which often results in device overheating and can potentially damage the device.

Since the driver draws current from the  $V_{DD}$  pin to bias all internal circuits, for the best high-speed circuit performance, Multi-Layer Ceramic Capacitor (MLCC) bypass capacitors are recommended to prevent noise problems. A 1  $\mu$ F MLCC type capacitor should be located as close as possible to the  $V_{DD}$  to GND pins of the gate driver.

### Operating Supply Current

The driver IC in the CSD43301Q5M has a low quiescent current in normal operation.  $I_{DDQ}$  is less than 0.2 mA when the device is disabled (SD = 0). The operating current vs. supply voltage is shown in [Figure 9](#), and the operating current vs. frequency is shown in [Figure 10](#).

### Input Stage

The input pins (IN and SD) of the CSD43301Q5M are based on a TTL/CMOS compatible input threshold logic that is independent of the  $V_{DD}$  supply voltage. With a typical high threshold of 2.2 V and a typical low threshold of 1.2 V, the logic level thresholds can be conveniently driven with PWM control signals derived from 3.3-V or 5-V digital power controllers. Wider hysteresis (typical of 0.8 V) offers enhanced noise immunity compared to traditional TTL logic implementations, where the hysteresis is typically less than 0.5 V. These devices also feature tight control of the input pin threshold voltage levels which eases system design considerations and ensures stable operation across temperature. The very low input capacitance on these pins reduces loading and increases switching speed. The device features an important safety function wherein, whenever any of the input pins are in a floating condition, the output of the respective channel is held in the low state. This is achieved using a  $V_{DD}$  pull-up resistor on the SD input or a GND pull-down resistor on the IN input. This can be seen in the block diagram in [Figure 3](#).

### Power Dissipation

Power Dissipation of the CSD43301Q5M used in secondary rectification is given by the following:

$$P_{LOSS} = P_{DRV} + P_{COND} + P_{SW} \quad (1)$$

where driver loss is given by

$$P_{DRV} = V_{DD} \times I_{DD} \quad (2)$$

and conduction loss is given by

$$P_{COND} = I_{D\_RMS}^2 \times R_{ON} \quad (3)$$

Switching losses consist of body diode conduction losses during dead time, body diode reverse recovery losses, and output charge losses, given by the following:

$$P_{SW} = I_D \times V_F \times (DT_R + DT_F) \times F_{SW} + Q_{RR} \times V_{DRAIN} \times F_{SW} + \frac{1}{2} Q_{OSS} \times V_{DRAIN} \times F_{SW} \quad (4)$$

## Recommended PCB Design Overview

The CSD43301Q5M features extremely low nominal  $R_{ON}$ . In order to maximize the performance of this device, some simple layout guidelines should be followed.

- The DRAIN pins of the CSD43301Q5M should be placed as close as possible to the inductor and connected with a short wide trace. This reduces PCB conduction losses and reduce switching noise level. <sup>(1)</sup>
- The GND pin (pin 7) must be connected into the thermal pad (pin 13) on the bottom of the device via a copper pour (without thermal spokes) for maximum performance.
- The CSD43301Q5M has the ability to use the GND planes as the primary thermal path. As such, the use of thermal vias is an effective way to pull away heat from the device and into the system board. Concerns of solder voids and manufacturability problems can be addressed by the use of three basic tactics to minimize the amount of solder attach that will wick down via the barrel:
  - Intentionally space out the vias from each other to avoid a cluster of holes in a given area.
  - Use the smallest drill size allowed in your design. The example in [Figure 11](#) uses vias with a 10 mil drill hole and a 16 mil capture pad.
  - Tent the opposite side of the via with a solder mask.

In the end, the number and size of the thermal vias should align with the end user's PCB design rules and manufacturing types.

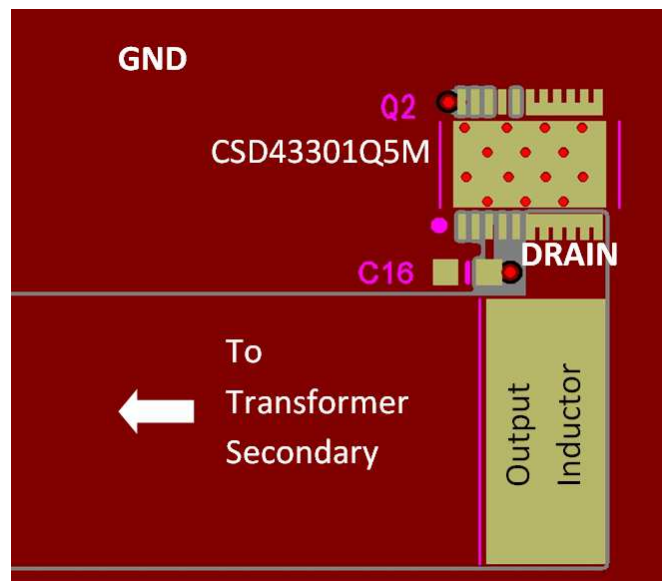

**Figure 11. Recommended PCB Layout (Top Down View)**

(1) Keong W. Kam, David Pommerenke, "EMI Analysis Methods for Synchronous Buck Converter EMI Root Cause Analysis", University of Missouri – Rolla

**MECHANICAL DATA**

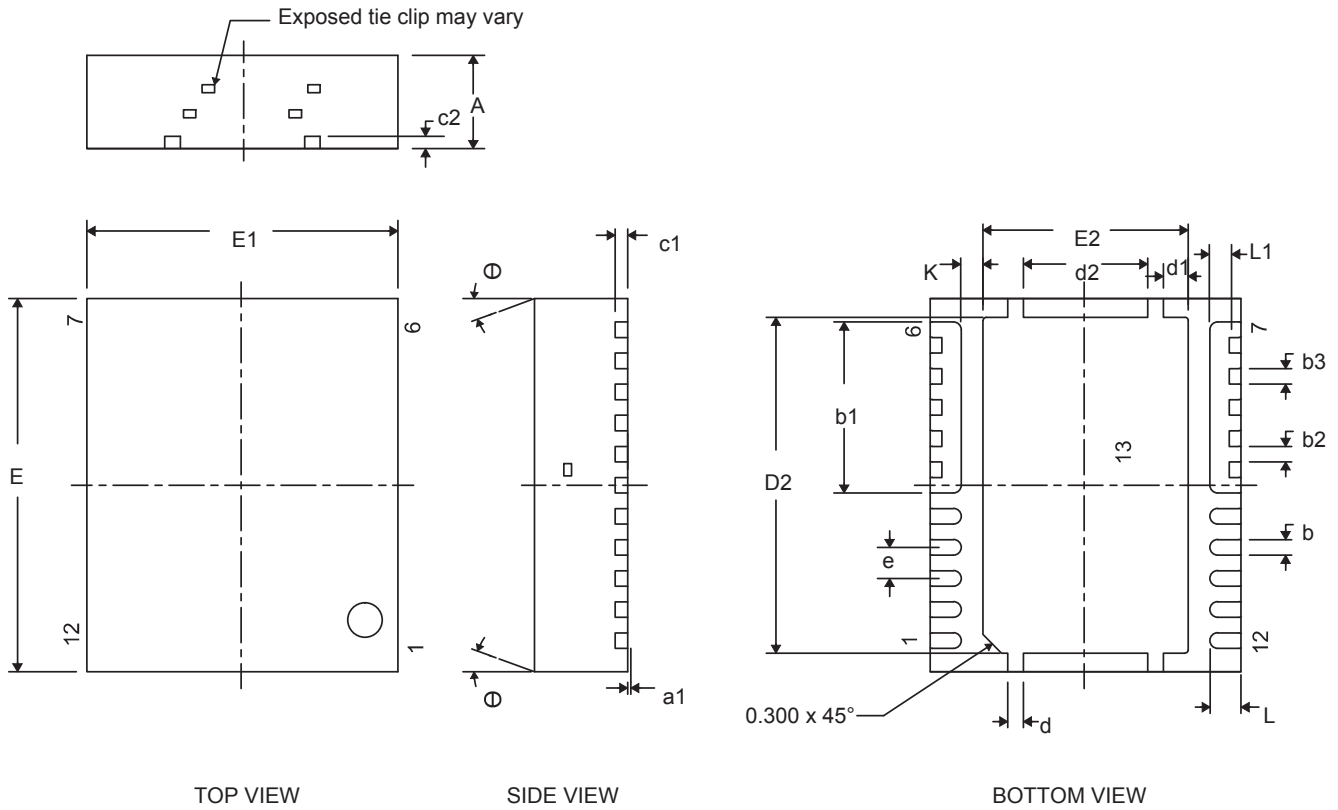

DIM	MILLIMETERS			INCHES		
	Min	Nom	Max	Min	Nom	Max
A	1.400	1.450	1.500	0.055	0.057	0.059
A1	0.000	0.000	0.050	0.000	0.000	0.002
b	0.200	0.250	0.350	0.008	0.010	0.013
b1	2.750 TYP			0.108 TYP		
b2	0.200	0.250	0.320	0.008	0.010	0.013
b3	0.250 TYP			0.010 TYP		
c1	0.150	0.200	0.250	0.006	0.008	0.010
c2	0.150	0.200	0.250	0.006	0.008	0.010
D2	5.300	5.400	5.500	0.209	0.213	0.217
d	0.200	0.250	0.300	0.008	0.010	0.012
d1	0.350	0.400	0.450	0.014	0.016	0.018
d2	1.900	2.000	2.100	0.075	0.079	0.083
E	5.900	6.000	6.100	0.232	0.236	0.240
E1	4.900	5.000	5.100	0.193	0.197	0.201
E2	3.200	3.300	3.400	0.126	0.130	0.134
e	0.500 TYP			0.020 TYP		
K	0.350 TYP			0.014 TYP		
L	0.400	0.500	0.600	0.016	0.020	0.024
L1	0.210	0.310	0.410	0.008	0.012	0.016
$\theta$	0.00	—	—	0.00	—	—



**REVISION HISTORY****Changes from Original (December 2012) to Revision A** **Page**

- 
- Changed [Figure 3](#) ..... 4
- 

**Changes from Revision A (December 2012) to Revision B** **Page**

- 
- Changed the MECHANICAL DATA image and corresponding table ..... 9
  - Changed the Recommended PCB Pattern - lead width From: 0.300(0.012) To: 0.350(0.014) ..... 10
  - Changed the Recommended Stencil image ..... 10
-

**PACKAGING INFORMATION**

Orderable Device	Status (1)	Package Type	Package Drawing	Pins	Package Qty	Eco Plan (2)	Lead/Ball Finish (6)	MSL Peak Temp (3)	Op Temp (°C)	Device Marking (4/5)	Samples
CSD43301Q5M	ACTIVE	LSON-CLIP	DQP	12	2500	Pb-Free (RoHS Exempt)	NIPDAU	Level-2-260C-1 YEAR	-55 to 125	43301M	<a href="#">Samples</a>

(1) The marketing status values are defined as follows:

**ACTIVE:** Product device recommended for new designs.

**LIFEBUY:** TI has announced that the device will be discontinued, and a lifetime-buy period is in effect.

**NRND:** Not recommended for new designs. Device is in production to support existing customers, but TI does not recommend using this part in a new design.

**PREVIEW:** Device has been announced but is not in production. Samples may or may not be available.

**OBSOLETE:** TI has discontinued the production of the device.

(2) **RoHS:** TI defines "RoHS" to mean semiconductor products that are compliant with the current EU RoHS requirements for all 10 RoHS substances, including the requirement that RoHS substance do not exceed 0.1% by weight in homogeneous materials. Where designed to be soldered at high temperatures, "RoHS" products are suitable for use in specified lead-free processes. TI may reference these types of products as "Pb-Free".

**RoHS Exempt:** TI defines "RoHS Exempt" to mean products that contain lead but are compliant with EU RoHS pursuant to a specific EU RoHS exemption.

**Green:** TI defines "Green" to mean the content of Chlorine (Cl) and Bromine (Br) based flame retardants meet JS709B low halogen requirements of <=1000ppm threshold. Antimony trioxide based flame retardants must also meet the <=1000ppm threshold requirement.

(3) MSL, Peak Temp. - The Moisture Sensitivity Level rating according to the JEDEC industry standard classifications, and peak solder temperature.

(4) There may be additional marking, which relates to the logo, the lot trace code information, or the environmental category on the device.

(5) Multiple Device Markings will be inside parentheses. Only one Device Marking contained in parentheses and separated by a "~" will appear on a device. If a line is indented then it is a continuation of the previous line and the two combined represent the entire Device Marking for that device.

(6) Lead/Ball Finish - Orderable Devices may have multiple material finish options. Finish options are separated by a vertical ruled line. Lead/Ball Finish values may wrap to two lines if the finish value exceeds the maximum column width.

**Important Information and Disclaimer:**The information provided on this page represents TI's knowledge and belief as of the date that it is provided. TI bases its knowledge and belief on information provided by third parties, and makes no representation or warranty as to the accuracy of such information. Efforts are underway to better integrate information from third parties. TI has taken and continues to take reasonable steps to provide representative and accurate information but may not have conducted destructive testing or chemical analysis on incoming materials and chemicals. TI and TI suppliers consider certain information to be proprietary, and thus CAS numbers and other limited information may not be available for release.

In no event shall TI's liability arising out of such information exceed the total purchase price of the TI part(s) at issue in this document sold by TI to Customer on an annual basis.

## IMPORTANT NOTICE AND DISCLAIMER

TI PROVIDES TECHNICAL AND RELIABILITY DATA (INCLUDING DATASHEETS), DESIGN RESOURCES (INCLUDING REFERENCE DESIGNS), APPLICATION OR OTHER DESIGN ADVICE, WEB TOOLS, SAFETY INFORMATION, AND OTHER RESOURCES "AS IS" AND WITH ALL FAULTS, AND DISCLAIMS ALL WARRANTIES, EXPRESS AND IMPLIED, INCLUDING WITHOUT LIMITATION ANY IMPLIED WARRANTIES OF MERCHANTABILITY, FITNESS FOR A PARTICULAR PURPOSE OR NON-INFRINGEMENT OF THIRD PARTY INTELLECTUAL PROPERTY RIGHTS.

These resources are intended for skilled developers designing with TI products. You are solely responsible for (1) selecting the appropriate TI products for your application, (2) designing, validating and testing your application, and (3) ensuring your application meets applicable standards, and any other safety, security, or other requirements. These resources are subject to change without notice. TI grants you permission to use these resources only for development of an application that uses the TI products described in the resource. Other reproduction and display of these resources is prohibited. No license is granted to any other TI intellectual property right or to any third party intellectual property right. TI disclaims responsibility for, and you will fully indemnify TI and its representatives against, any claims, damages, costs, losses, and liabilities arising out of your use of these resources.

TI's products are provided subject to TI's Terms of Sale ([www.ti.com/legal/termsofsale.html](http://www.ti.com/legal/termsofsale.html)) or other applicable terms available either on [ti.com](http://ti.com) or provided in conjunction with such TI products. TI's provision of these resources does not expand or otherwise alter TI's applicable warranties or warranty disclaimers for TI products.

Mailing Address: Texas Instruments, Post Office Box 655303, Dallas, Texas 75265  
Copyright © 2020, Texas Instruments Incorporated