

## LM3290 Product Brief

### 1 Features

- **V<sub>OUT\_RANGE</sub>**
  - V<sub>OUT\_ET</sub> = 0.6 V to 4.5 V
  - V<sub>OUT\_APT</sub> = 0.4 V to 3.81 V (or V<sub>IN</sub> – 200 mV)
- **DC Boost For ET Operation:**
  - Boost Input Voltage Range: 2.5 V to 5 V
  - High-Efficiency (90% typical) with Internal Synchronous Rectification
  - Boost Bypass Function with Low Resistance (150 mΩ typ.)
  - 2.7-MHz PWM Switching Frequency
- **Buck DC-DC for APT and ET Operation:**
  - High Operating Frequency for Small External Inductor and Capacitors
  - V<sub>OUT\_RANGE</sub> = 0.4 V to 3.81 V (or V<sub>IN</sub> – 200 mV)
  - High-Efficiency (95% typical) with Internal Synchronous Rectification
  - Low-Power PFM Mode
- **LM3291 Control:**
  - Automatic Control of LM3291 in ET Mode
- **RFFE Control Interface:**
  - 1.8-V MIPI® RFFE 1.1-Compatible Digital Control Interface
  - 26-MHz Write Capability
  - 13-MHz Read Capability

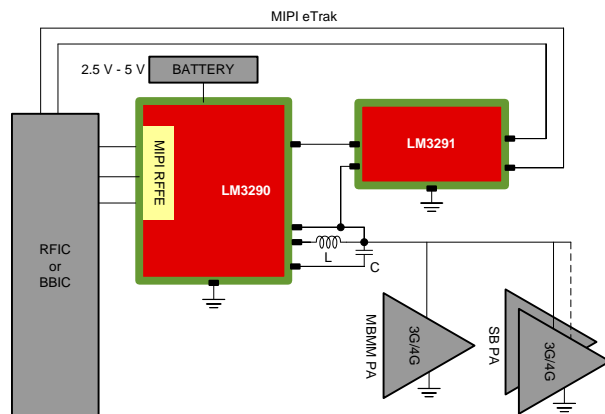

### 2 Description

The LM3290, with its companion IC LM3291, is an RF envelope supply modulator (EM) with integrated DC-DC boost converter optimized for Envelope Tracking (ET) RF power amplifiers (PAs). The device enables maximum transmit output power independent of the input battery voltage (battery as low as 2.5 V) and is controlled by the MIPI® RFFE 1.1.

The LM3290 operates in two active modes:

**Active Mode 1:** For low TX output power, LM3290 may operate in Average Power Tracking (APT) mode, providing a static, but programmable, output voltage to supply the PA. At light load and in APT mode, the LM3290 enters into Pulse Frequency Mode (PFM) operation automatically and operates with reduced switching frequency. In PFM mode, the quiescent current is reduced, which extends the battery life.

**Active Mode 2:** In ET mode, the LM3290 with LM3291 efficiently provides a dynamic, high-bandwidth supply voltage for the PA to maximize total EM + PA efficiency. The envelope modulator follows the envelope reference input signal delivered by the RFIC to the LM3291 via a differential analog input. The output is a single-ended power supply signal to the PA.

The LM3290 and LM3291 support 3G, as well as LTE operation up to 20-MHz signal bandwidth.

The LM3290 controls the LM3291 companion-IC through direct control signals, and no additional controls are needed from the system. Shutdown, standby, and idle modes turn the EM off and reduce battery current consumption.

**For the full datasheet, samples, or the EVM hardware and software please contact a TI representative at ET@list.ti.com.**

#### Device Information <sup>(1)</sup>

PART NUMBER	PACKAGE	BODY SIZE (NOM)
LM3290	DSBGA (30)	2.432 mm x 2.808 mm

(1) For all available packages, see the orderable addendum at the end of the datasheet.



### 3 Revision History

**Changes from Original (August 2013) to Revision A****Page**

- 
- Changed First page layout; added Device Information table; Device and Documentation Support page ..... 1
-

## 4 Device and Documentation Support

### 4.1 Trademarks

MIPI is a registered trademark of Mobile Industry Processor Interface Alliance. All other trademarks are the property of their respective owners.

### 4.2 Electrostatic Discharge Caution



This integrated circuit can be damaged by ESD. Texas Instruments recommends that all integrated circuits be handled with appropriate precautions. Failure to observe proper handling and installation procedures can cause damage.

ESD damage can range from subtle performance degradation to complete device failure. Precision integrated circuits may be more susceptible to damage because very small parametric changes could cause the device not to meet its published specifications.

### 4.3 Glossary

[SLYZ022](#) — *TI Glossary*.

This glossary lists and explains terms, acronyms and definitions.

## 5 Mechanical, Packaging, and Orderable Information

The following pages include mechanical, packaging, and orderable information. This information is the most current data available for the designated devices. This data is subject to change without notice and revision of this document. For browser-based versions of this data sheet, refer to the left-hand navigation.

**PACKAGING INFORMATION**

Orderable Device	Status (1)	Package Type	Package Drawing	Pins	Package Qty	Eco Plan (2)	Lead/Ball Finish (6)	MSL Peak Temp (3)	Op Temp (°C)	Device Marking (4/5)	Samples
LM3290TME/NOPB	ACTIVE	DSBGA	YFQ	30	250	Green (RoHS & no Sb/Br)	SNAGCU	Level-1-260C-UNLIM	-30 to 85	3290	<a href="#">Samples</a>
LM3290TMX/NOPB	ACTIVE	DSBGA	YFQ	30	3000	Green (RoHS & no Sb/Br)	SNAGCU	Level-1-260C-UNLIM	-30 to 85	3290	<a href="#">Samples</a>

(1) The marketing status values are defined as follows:

**ACTIVE:** Product device recommended for new designs.

**LIFEBUY:** TI has announced that the device will be discontinued, and a lifetime-buy period is in effect.

**NRND:** Not recommended for new designs. Device is in production to support existing customers, but TI does not recommend using this part in a new design.

**PREVIEW:** Device has been announced but is not in production. Samples may or may not be available.

**OBSOLETE:** TI has discontinued the production of the device.

(2) **RoHS:** TI defines "RoHS" to mean semiconductor products that are compliant with the current EU RoHS requirements for all 10 RoHS substances, including the requirement that RoHS substance do not exceed 0.1% by weight in homogeneous materials. Where designed to be soldered at high temperatures, "RoHS" products are suitable for use in specified lead-free processes. TI may reference these types of products as "Pb-Free".

**RoHS Exempt:** TI defines "RoHS Exempt" to mean products that contain lead but are compliant with EU RoHS pursuant to a specific EU RoHS exemption.

**Green:** TI defines "Green" to mean the content of Chlorine (Cl) and Bromine (Br) based flame retardants meet JS709B low halogen requirements of <=1000ppm threshold. Antimony trioxide based flame retardants must also meet the <=1000ppm threshold requirement.

(3) MSL, Peak Temp. - The Moisture Sensitivity Level rating according to the JEDEC industry standard classifications, and peak solder temperature.

(4) There may be additional marking, which relates to the logo, the lot trace code information, or the environmental category on the device.

(5) Multiple Device Markings will be inside parentheses. Only one Device Marking contained in parentheses and separated by a "~" will appear on a device. If a line is indented then it is a continuation of the previous line and the two combined represent the entire Device Marking for that device.

(6) Lead/Ball Finish - Orderable Devices may have multiple material finish options. Finish options are separated by a vertical ruled line. Lead/Ball Finish values may wrap to two lines if the finish value exceeds the maximum column width.

**Important Information and Disclaimer:**The information provided on this page represents TI's knowledge and belief as of the date that it is provided. TI bases its knowledge and belief on information provided by third parties, and makes no representation or warranty as to the accuracy of such information. Efforts are underway to better integrate information from third parties. TI has taken and continues to take reasonable steps to provide representative and accurate information but may not have conducted destructive testing or chemical analysis on incoming materials and chemicals. TI and TI suppliers consider certain information to be proprietary, and thus CAS numbers and other limited information may not be available for release.

In no event shall TI's liability arising out of such information exceed the total purchase price of the TI part(s) at issue in this document sold by TI to Customer on an annual basis.



## TAPE AND REEL INFORMATION



### QUADRANT ASSIGNMENTS FOR PIN 1 ORIENTATION IN TAPE



\*All dimensions are nominal

Device	Package Type	Package Drawing	Pins	SPQ	Reel Diameter (mm)	Reel Width W1 (mm)	A0 (mm)	B0 (mm)	K0 (mm)	P1 (mm)	W (mm)	Pin1 Quadrant
LM3290TME/NOPB	DSBGA	YFQ	30	250	178.0	8.4	2.67	2.95	0.76	4.0	8.0	Q1
LM3290TMX/NOPB	DSBGA	YFQ	30	3000	178.0	8.4	2.67	2.95	0.76	4.0	8.0	Q1

**TAPE AND REEL BOX DIMENSIONS**

\*All dimensions are nominal

Device	Package Type	Package Drawing	Pins	SPQ	Length (mm)	Width (mm)	Height (mm)
LM3290TME/NOPB	DSBGA	YFQ	30	250	210.0	185.0	35.0
LM3290TMX/NOPB	DSBGA	YFQ	30	3000	210.0	185.0	35.0

## IMPORTANT NOTICE AND DISCLAIMER

TI PROVIDES TECHNICAL AND RELIABILITY DATA (INCLUDING DATASHEETS), DESIGN RESOURCES (INCLUDING REFERENCE DESIGNS), APPLICATION OR OTHER DESIGN ADVICE, WEB TOOLS, SAFETY INFORMATION, AND OTHER RESOURCES "AS IS" AND WITH ALL FAULTS, AND DISCLAIMS ALL WARRANTIES, EXPRESS AND IMPLIED, INCLUDING WITHOUT LIMITATION ANY IMPLIED WARRANTIES OF MERCHANTABILITY, FITNESS FOR A PARTICULAR PURPOSE OR NON-INFRINGEMENT OF THIRD PARTY INTELLECTUAL PROPERTY RIGHTS.

These resources are intended for skilled developers designing with TI products. You are solely responsible for (1) selecting the appropriate TI products for your application, (2) designing, validating and testing your application, and (3) ensuring your application meets applicable standards, and any other safety, security, or other requirements. These resources are subject to change without notice. TI grants you permission to use these resources only for development of an application that uses the TI products described in the resource. Other reproduction and display of these resources is prohibited. No license is granted to any other TI intellectual property right or to any third party intellectual property right. TI disclaims responsibility for, and you will fully indemnify TI and its representatives against, any claims, damages, costs, losses, and liabilities arising out of your use of these resources.

TI's products are provided subject to TI's Terms of Sale ([www.ti.com/legal/termsofsale.html](http://www.ti.com/legal/termsofsale.html)) or other applicable terms available either on [ti.com](http://ti.com) or provided in conjunction with such TI products. TI's provision of these resources does not expand or otherwise alter TI's applicable warranties or warranty disclaimers for TI products.

Mailing Address: Texas Instruments, Post Office Box 655303, Dallas, Texas 75265  
Copyright © 2019, Texas Instruments Incorporated