

## LM195/LM395 Ultra Reliable Power Transistors

 Check for Samples: [LM195](#), [LM395](#)

### FEATURES

- **Internal Thermal Limiting**
- **Greater than 1.0A Output Current**
- **3.0  $\mu$ A Typical Base Current**
- **500 ns Switching Time**
- **2.0V Saturation**
- **Base Can be Driven up to 40V without Damage**
- **Directly Interfaces with CMOS or TTL**
- **100% Electrical Burn-in**

### DESCRIPTION

The LM195/LM395 are fast, monolithic power integrated circuits with complete overload protection. These devices, which act as high gain power transistors, have included on the chip, current limiting, power limiting, and thermal overload protection making them virtually impossible to destroy from any type of overload. In the standard TO-3 transistor power package, the LM195 will deliver load currents in excess of 1.0A and can switch 40V in 500 ns.

The inclusion of thermal limiting, a feature not easily available in discrete designs, provides virtually absolute protection against overload. Excessive power dissipation or inadequate heat sinking causes the thermal limiting circuitry to turn off the device preventing excessive heating.

The LM195 offers a significant increase in reliability as well as simplifying power circuitry. In some applications, where protection is unusually difficult, such as switching regulators, lamp or solenoid drivers where normal power dissipation is low, the LM195 is especially advantageous.

The LM195 is easy to use and only a few precautions need be observed. Excessive collector to emitter voltage can destroy the LM195 as with any power transistor. When the device is used as an emitter follower with low source impedance, it is necessary to insert a 5.0k resistor in series with the base lead to prevent possible emitter follower oscillations. Although the device is usually stable as an emitter follower, the resistor eliminates the possibility of trouble without degrading performance. Finally, since it has good high frequency response, supply bypassing is recommended.

For low-power applications (under 100 mA), refer to the LP395 Ultra Reliable Power Transistor.

The LM195/LM395 are available in the standard TO-3, Kovar TO-5, and TO-220 packages. The LM195 is rated for operation from  $-55^{\circ}\text{C}$  to  $+150^{\circ}\text{C}$  and the LM395 from  $0^{\circ}\text{C}$  to  $+125^{\circ}\text{C}$ .

### Simplified Circuit

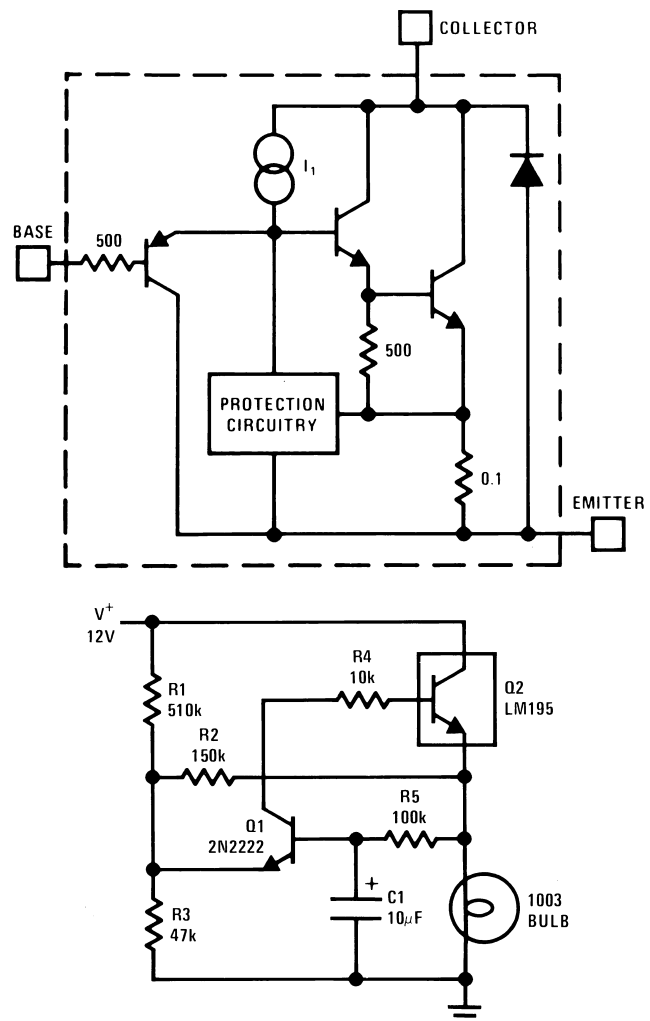

Figure 1. 1.0 Amp Lamp Flasher



Please be aware that an important notice concerning availability, standard warranty, and use in critical applications of Texas Instruments semiconductor products and disclaimers thereto appears at the end of this data sheet.

All trademarks are the property of their respective owners.

**Connection Diagram**

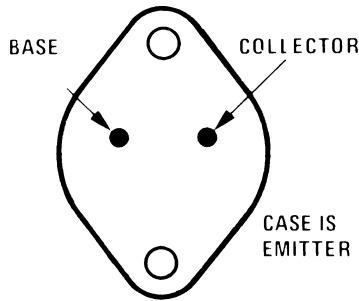

Refer to RETS195H and RETS195K drawings of military LM195H and LM195K versions for specifications.

**Figure 2. TO-3 Metal Can Package  
Bottom View  
See Package Number NDS0002A**

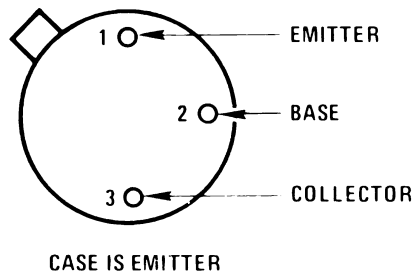

Refer to RETS195H and RETS195K drawings of military LM195H and LM195K versions for specifications.

**Figure 3. TO-5 Metal Can Package  
Bottom View**

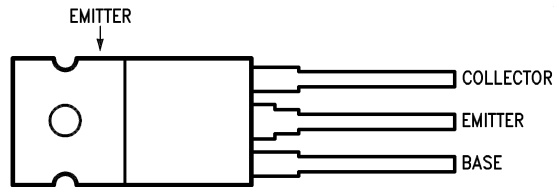

Case is Emitter

**Figure 4. TO-220 Plastic Package  
Top View  
See Package Number NDE0003B**



These devices have limited built-in ESD protection. The leads should be shorted together or the device placed in conductive foam during storage or handling to prevent electrostatic damage to the MOS gates.

## ABSOLUTE MAXIMUM RATINGS<sup>(1)(2)</sup>

Collector to Emitter Voltage	
LM195	42V
LM395	36V
Collector to Base Voltage	
LM195	42V
LM395	36V
Base to Emitter Voltage (Forward)	
LM195	42V
LM395	36V
Base to Emitter Voltage (Reverse)	20V
Collector Current	Internally Limited
Power Dissipation	Internally Limited
Operating Temperature Range	
LM195	-55°C to +150°C
LM395	0°C to +125°C
Storage Temperature Range	-65°C to +150°C
Lead Temperature	
(Soldering, 10 sec.)	260°C

- (1) "Absolute Maximum Ratings" indicate limits beyond which damage to the device may occur. Operating Ratings indicate conditions for which the device is functional, but do not ensure specific performance limits.
- (2) If Military/Aerospace specified devices are required, please contact the Texas Instruments Sales Office/Distributors for availability and specifications.

## PRECONDITIONING

<b>100% Burn-In In Thermal Limit</b>
--------------------------------------

## ELECTRICAL CHARACTERISTICS

Parameter	Conditions	LM195			LM395			Units
		Min	Typ	Max	Min	Typ	Max	
Collector-Emitter Operating Voltage <sup>(2)</sup>	$I_Q \leq I_C \leq I_{MAX}$			42			36	V
Base to Emitter Breakdown Voltage	$0 \leq V_{CE} \leq V_{CEMAX}$	42			36	60		V
Collector Current								A
TO-3, TO-220	$V_{CE} \leq 15V$	1.2	2.2		1.0	2.2		A
TO-5	$V_{CE} \leq 7.0V$	1.2	1.8		1.0	1.8		A
Saturation Voltage	$I_C \leq 1.0A, T_A = 25^\circ C$		1.8	2.0		1.8	2.2	V
Base Current	$0 \leq I_C \leq I_{MAX}$ $0 \leq V_{CE} \leq V_{CEMAX}$		3.0	5.0		3.0	10	$\mu A$
Quiescent Current ( $I_Q$ )	$V_{be} = 0$ $0 \leq V_{CE} \leq V_{CEMAX}$		2.0	5.0		2.0	10	mA
Base to Emitter Voltage	$I_C = 1.0A, T_A = +25^\circ C$		0.9			0.9		V
Switching Time	$V_{CE} = 36V, R_L = 36\Omega,$ $T_A = 25^\circ C$		500			500		ns

(1) Unless otherwise specified, these specifications apply for  $-55^\circ C \leq T_j \leq +150^\circ C$  for the LM195 and  $0^\circ C \leq +125^\circ C$  for the LM395.

(2) Selected devices with higher breakdown available.

**ELECTRICAL CHARACTERISTICS (continued)**

(1)

Parameter	Conditions	LM195			LM395			Units
		Min	Typ	Max	Min	Typ	Max	
Thermal Resistance Junction to Case <sup>(3)</sup>	TO-3 Package (NDS)		2.3	3.0		2.3	3.0	°C/W
	TO-5 Package		12	15		12	15	°C/W
	TO-220 Package (NDE)					4	6	°C/W

(3) Without a heat sink, the thermal resistance of the TO-5 package is about +150°C/W, while that of the TO-3 package is +35°C/W.

**TYPICAL PERFORMANCE CHARACTERISTICS**

(for NDS and NDE Packages)

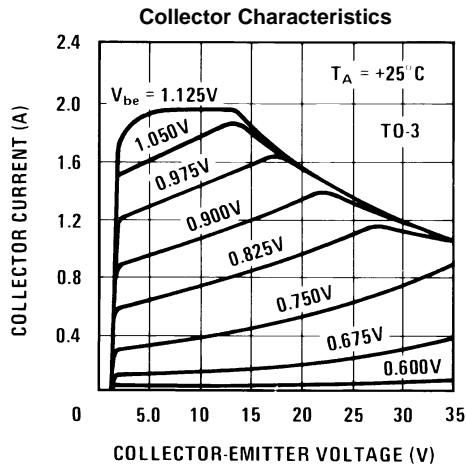

Figure 5.

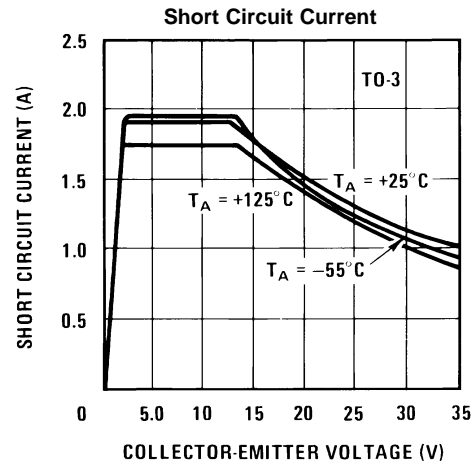

Figure 6.

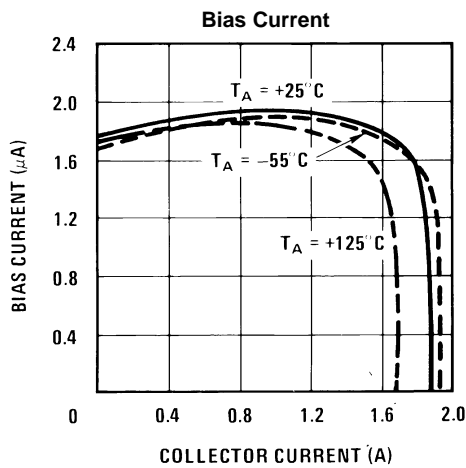

Figure 7.

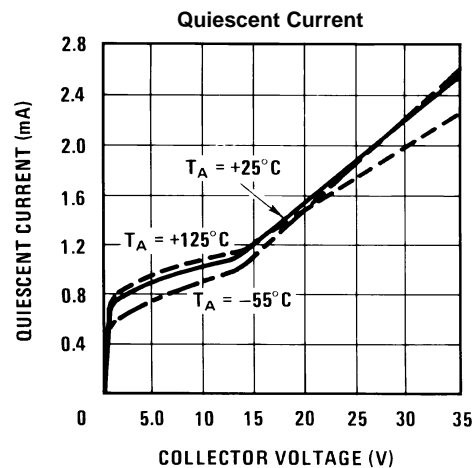

Figure 8.

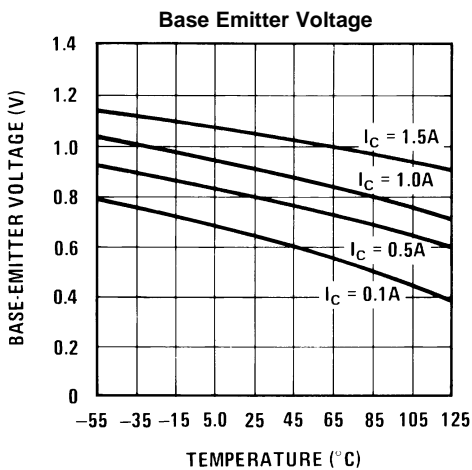

Figure 9.

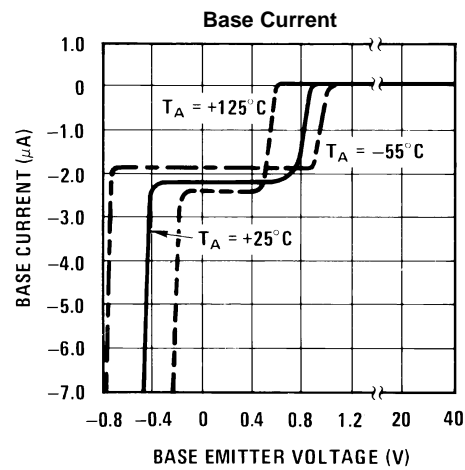

Figure 10.

**TYPICAL PERFORMANCE CHARACTERISTICS (continued)**

(for NDS and NDE Packages)

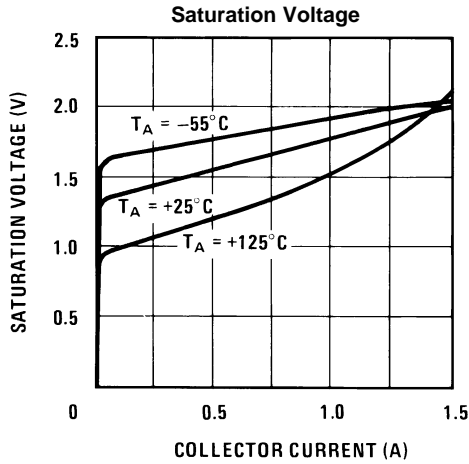

Figure 11.

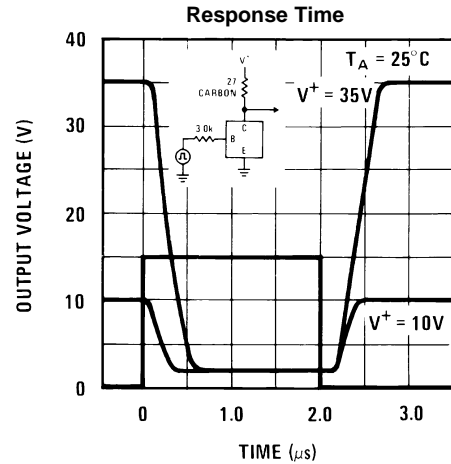

Figure 12.

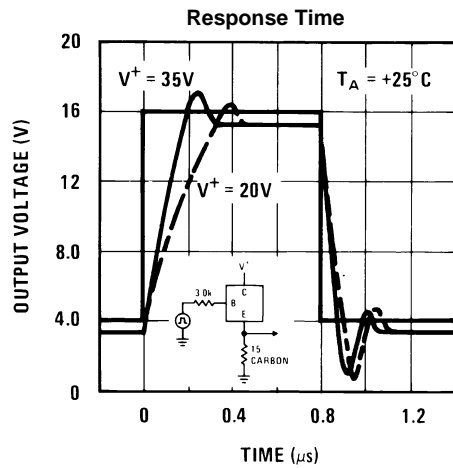

Figure 13.

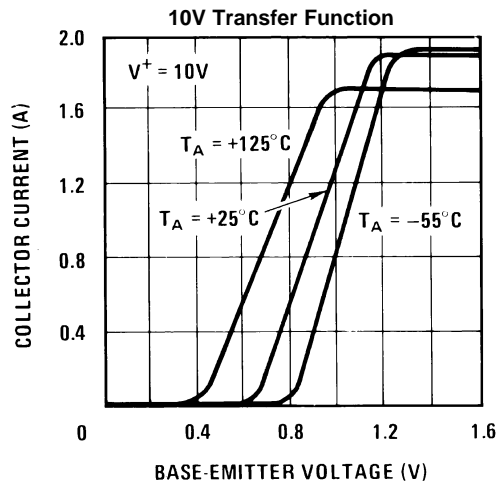

Figure 14.

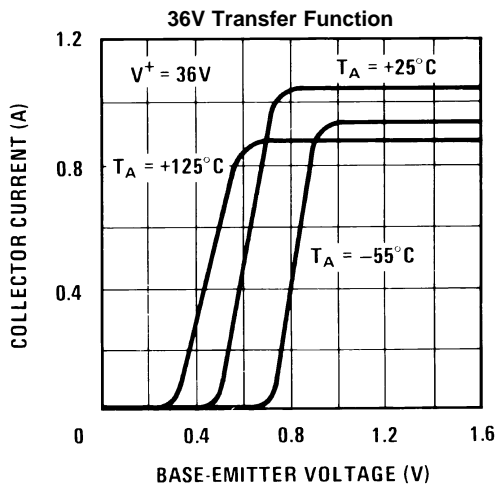

Figure 15.

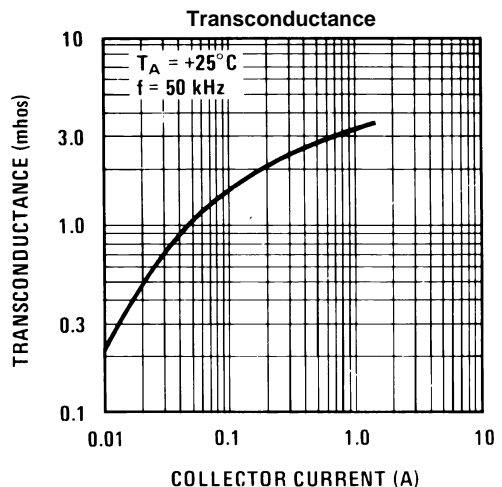
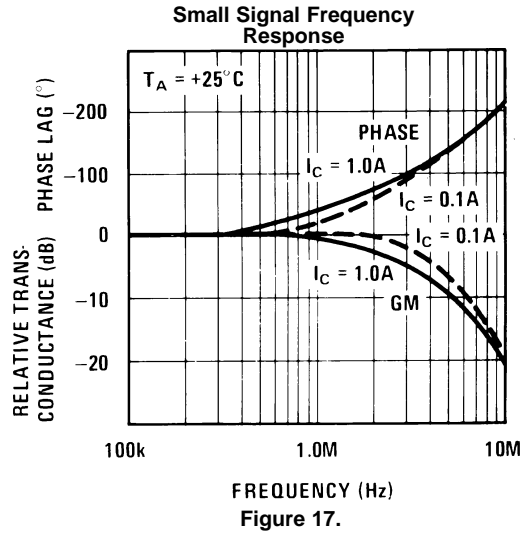

Figure 16.

**TYPICAL PERFORMANCE CHARACTERISTICS (continued)**

(for NDS and NDE Packages)







TYPICAL APPLICATIONS

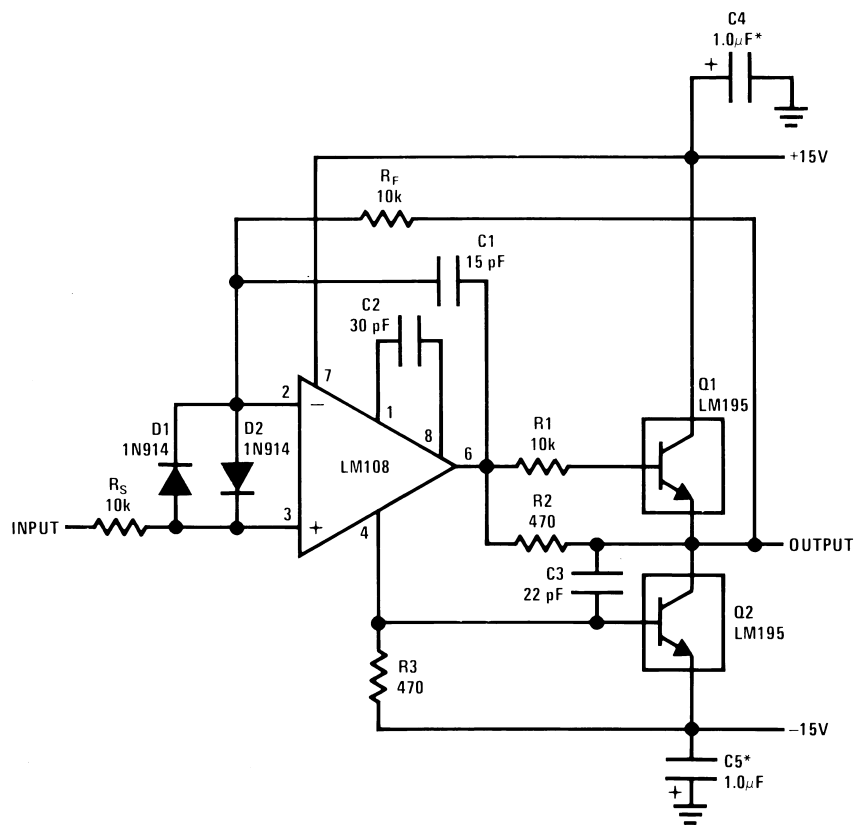

\*Solid Tantalum

Figure 18. 1.0 Amp Voltage Follower

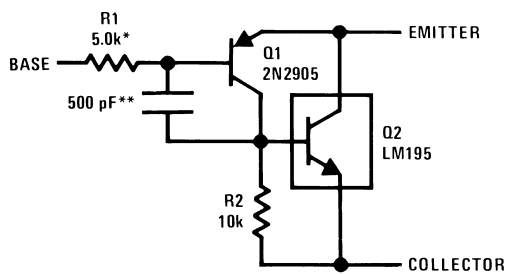

\*Protects against excessive base drive

\*\*Needed for stability

Figure 19. Power PNP

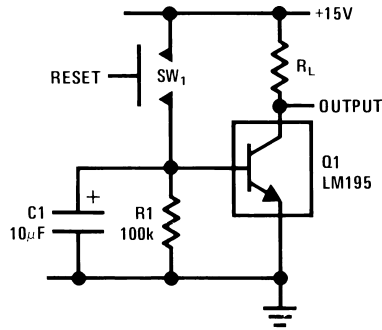

Figure 20. Time Delay

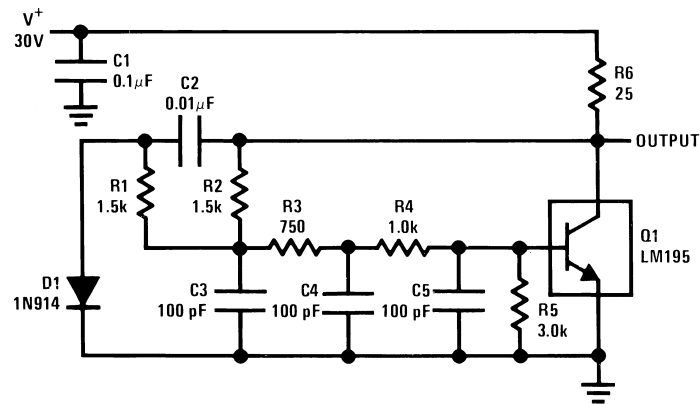
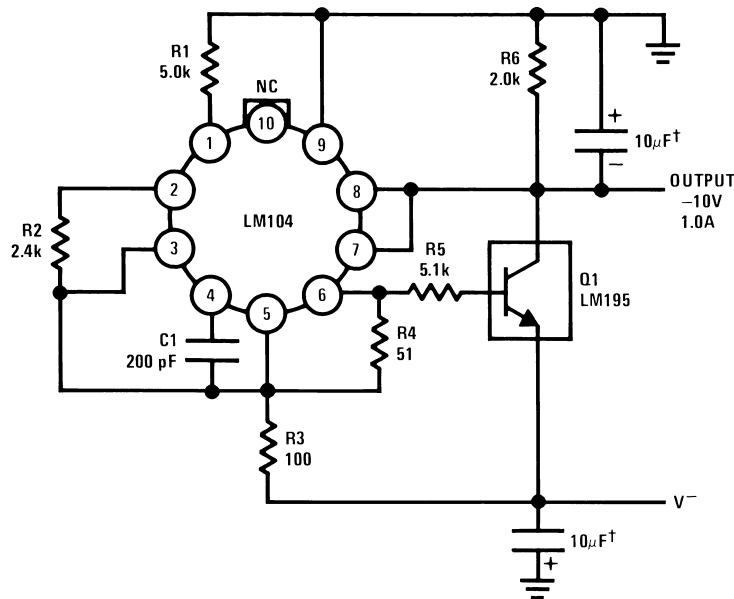
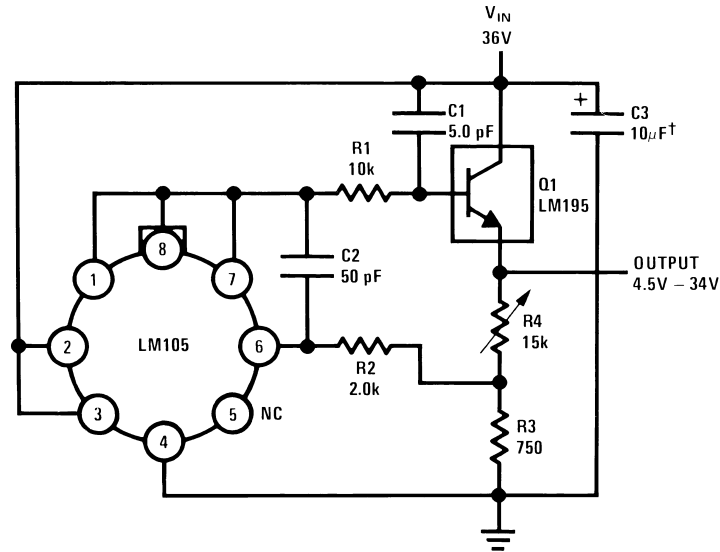

Figure 21. 1.0 MHz Oscillator



†Solid Tantalum

Figure 22. 1.0 Amp Negative Regulator



†Solid Tantalum

Figure 23. 1.0 Amp Positive Voltage Regulator

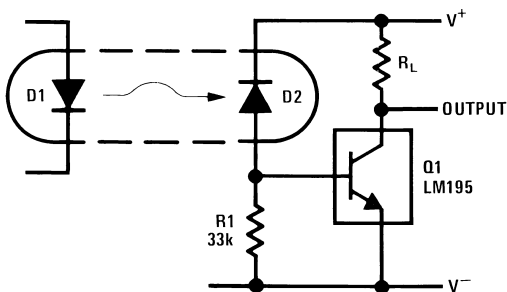

Figure 24. Fast Optically Isolated Switch

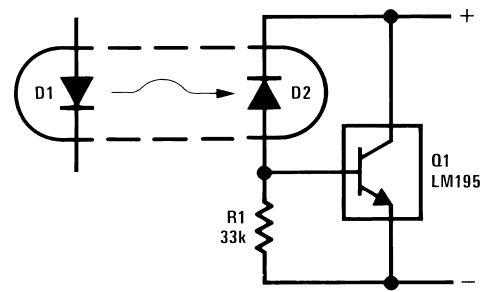

Figure 25. Optically Isolated Power Transistor

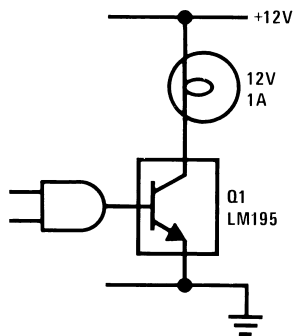

Figure 26. CMOS or TTL Lamp Interface

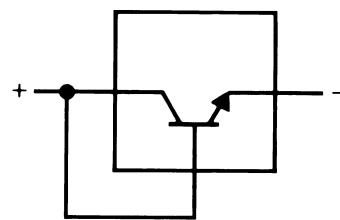
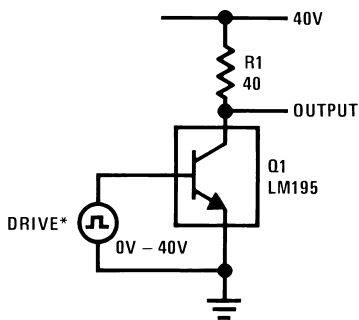

Figure 27. Two Terminal Current Limiter



\*Drive Voltage 0V to  $\geq 10V \leq 42V$

Figure 28. 40V Switch

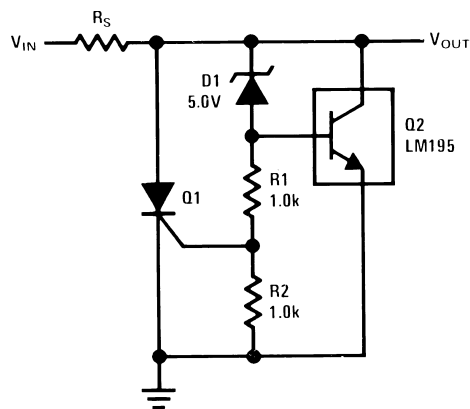

Figure 29. 6.0V Shunt Regulator with Crowbar

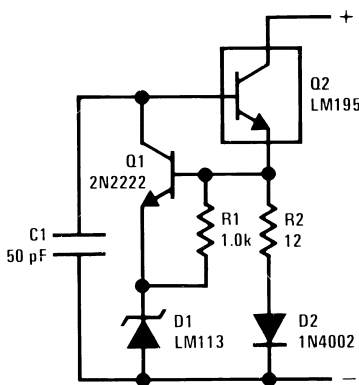
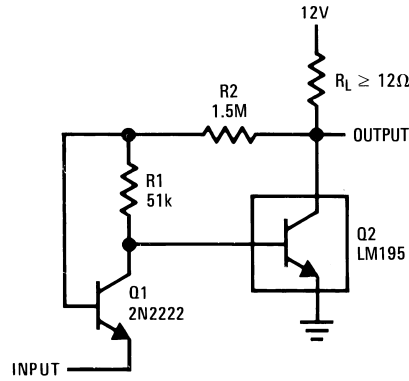
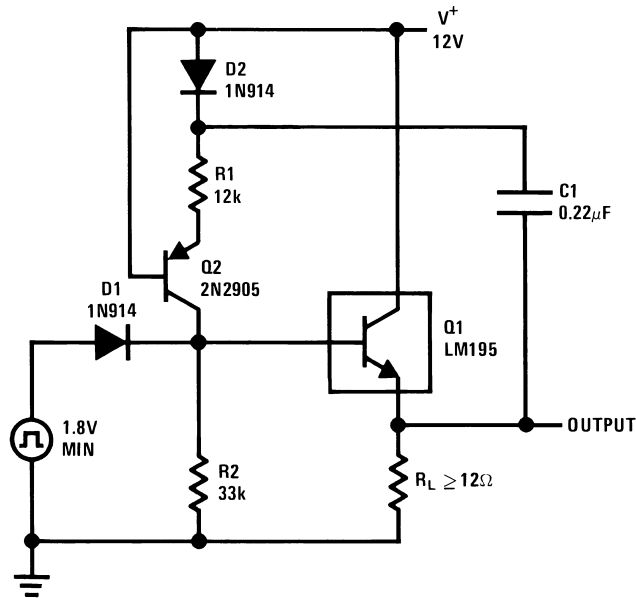

Figure 30. Two Terminal 100 mA Current Regulator



Turn ON = 350 mV  
Turn OFF = 200 mV

Figure 31. Low Level Power Switch



$T = R1C$   
 $R2 = 3R1$   
 $R2 \leq 82k$

Figure 32. Power One-Shot

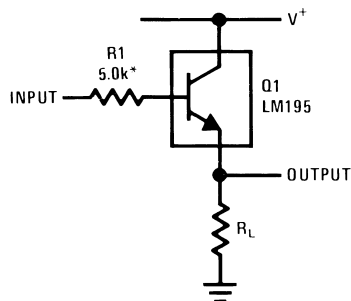

\*Need for Stability

Figure 33. Emitter Follower

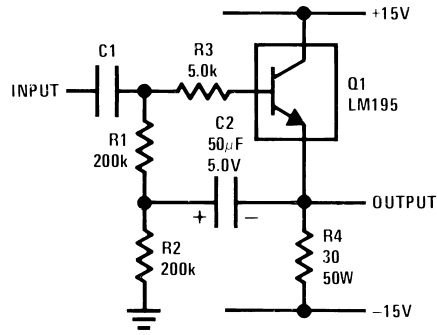
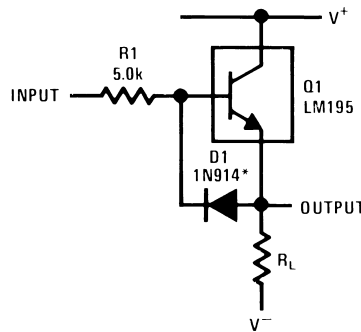
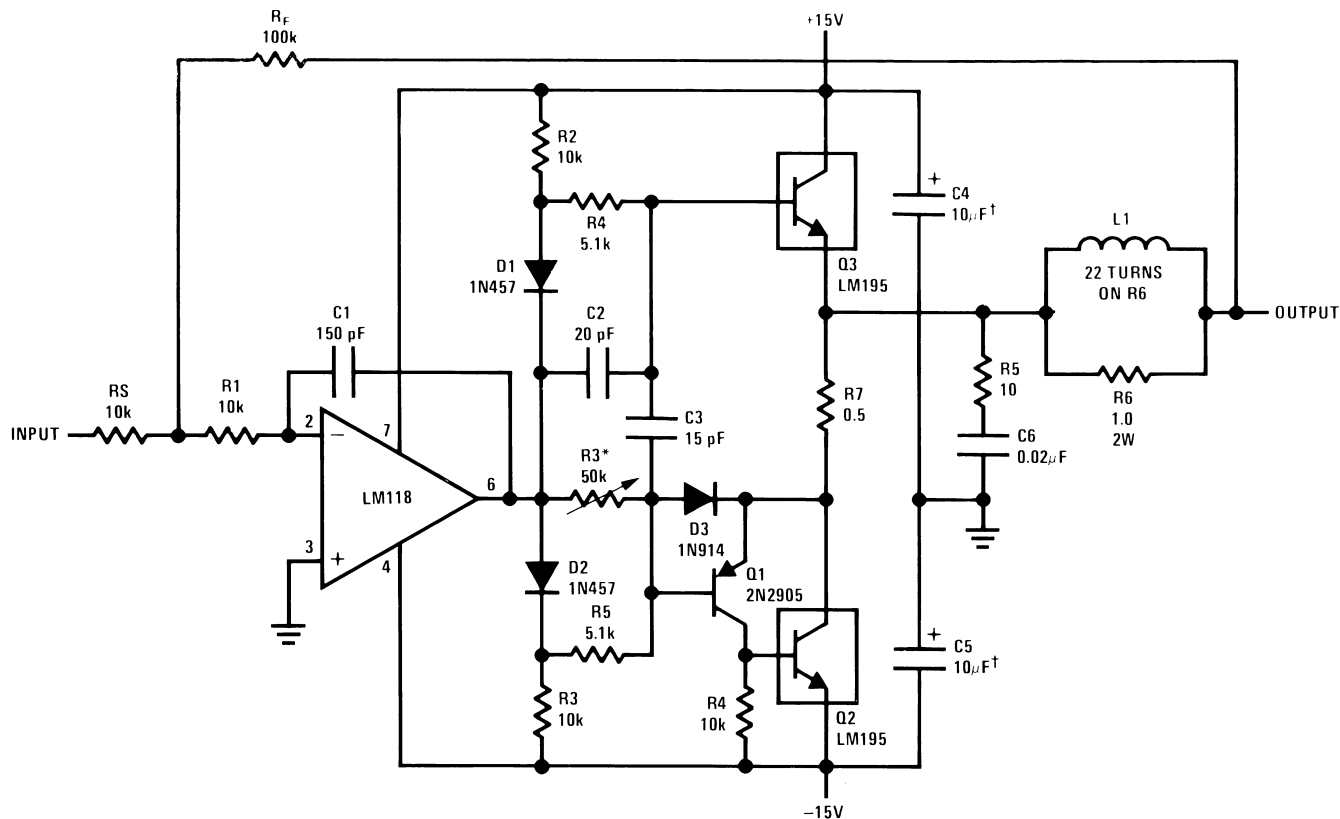

Figure 34. High Input Impedance AC Emitter Follower



\*Prevents storage with fast fall time square wave drive

Figure 35. Fast Follower



\*Adjust for 50 mA quiescent current  
 †Solid Tantalum

Figure 36. Power Op Amp

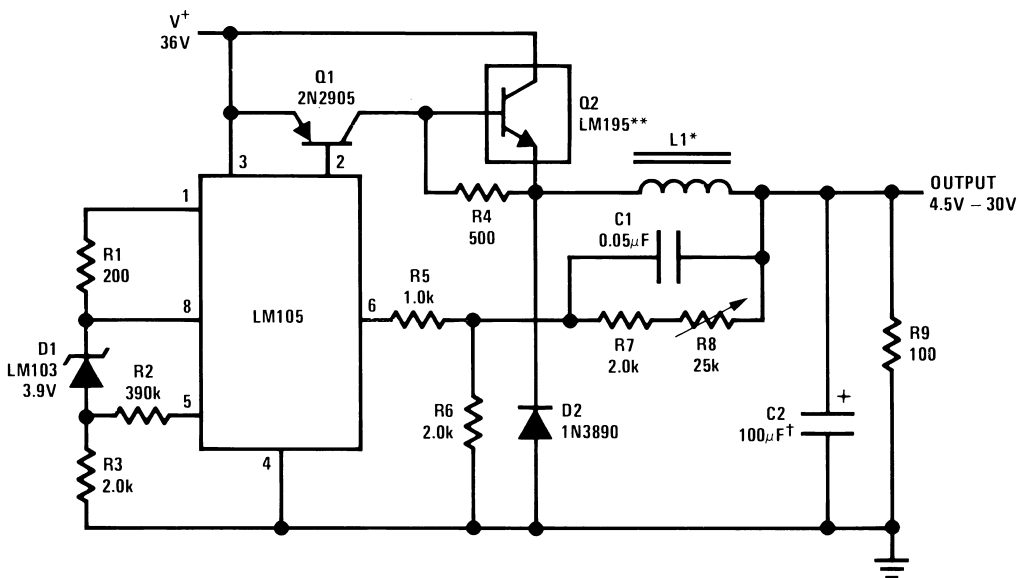

\*Sixty turns wound on Arnold Type A-083081-2 core.  
 \*\*Four devices in parallel  
 †Solid tantalum

Figure 37. 6.0 Amp Variable Output Switching Regulator

## REVISION HISTORY

Changes from Revision B (April 2013) to Revision C	Page
• Changed layout of National Data Sheet to TI format .....	<a href="#">15</a>



**PACKAGING INFORMATION**

Orderable Device	Status (1)	Package Type	Package Drawing	Pins	Package Qty	Eco Plan (2)	Lead/Ball Finish (6)	MSL Peak Temp (3)	Op Temp (°C)	Device Marking (4/5)	Samples
LM395T	NRND	TO-220	NDE	3	45	TBD	Call TI	Call TI	0 to 125	LM395T	
LM395T/NOPB	ACTIVE	TO-220	NDE	3	45	Green (RoHS & no Sb/Br)	SN	Level-1-NA-UNLIM	0 to 125	LM395T	Samples

(1) The marketing status values are defined as follows:

**ACTIVE:** Product device recommended for new designs.

**LIFEBUY:** TI has announced that the device will be discontinued, and a lifetime-buy period is in effect.

**NRND:** Not recommended for new designs. Device is in production to support existing customers, but TI does not recommend using this part in a new design.

**PREVIEW:** Device has been announced but is not in production. Samples may or may not be available.

**OBSELETE:** TI has discontinued the production of the device.

(2) **RoHS:** TI defines "RoHS" to mean semiconductor products that are compliant with the current EU RoHS requirements for all 10 RoHS substances, including the requirement that RoHS substance do not exceed 0.1% by weight in homogeneous materials. Where designed to be soldered at high temperatures, "RoHS" products are suitable for use in specified lead-free processes. TI may reference these types of products as "Pb-Free".

**RoHS Exempt:** TI defines "RoHS Exempt" to mean products that contain lead but are compliant with EU RoHS pursuant to a specific EU RoHS exemption.

**Green:** TI defines "Green" to mean the content of Chlorine (Cl) and Bromine (Br) based flame retardants meet JS709B low halogen requirements of <=1000ppm threshold. Antimony trioxide based flame retardants must also meet the <=1000ppm threshold requirement.

(3) MSL, Peak Temp. - The Moisture Sensitivity Level rating according to the JEDEC industry standard classifications, and peak solder temperature.

(4) There may be additional marking, which relates to the logo, the lot trace code information, or the environmental category on the device.

(5) Multiple Device Markings will be inside parentheses. Only one Device Marking contained in parentheses and separated by a "~" will appear on a device. If a line is indented then it is a continuation of the previous line and the two combined represent the entire Device Marking for that device.

(6) Lead/Ball Finish - Orderable Devices may have multiple material finish options. Finish options are separated by a vertical ruled line. Lead/Ball Finish values may wrap to two lines if the finish value exceeds the maximum column width.

**Important Information and Disclaimer:**The information provided on this page represents TI's knowledge and belief as of the date that it is provided. TI bases its knowledge and belief on information provided by third parties, and makes no representation or warranty as to the accuracy of such information. Efforts are underway to better integrate information from third parties. TI has taken and continues to take reasonable steps to provide representative and accurate information but may not have conducted destructive testing or chemical analysis on incoming materials and chemicals. TI and TI suppliers consider certain information to be proprietary, and thus CAS numbers and other limited information may not be available for release.

In no event shall TI's liability arising out of such information exceed the total purchase price of the TI part(s) at issue in this document sold by TI to Customer on an annual basis.

NDE0003B

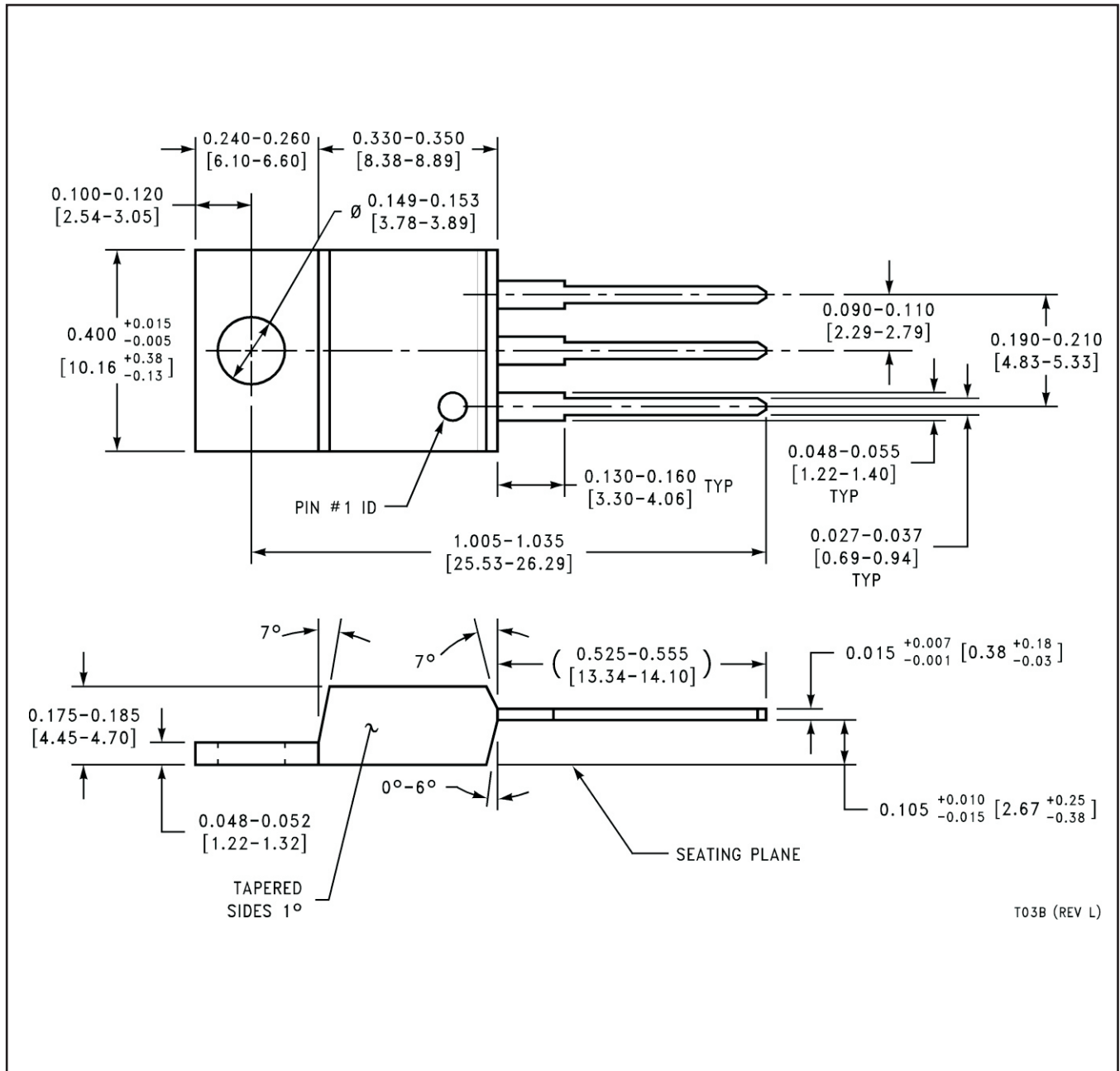

## IMPORTANT NOTICE AND DISCLAIMER

TI PROVIDES TECHNICAL AND RELIABILITY DATA (INCLUDING DATASHEETS), DESIGN RESOURCES (INCLUDING REFERENCE DESIGNS), APPLICATION OR OTHER DESIGN ADVICE, WEB TOOLS, SAFETY INFORMATION, AND OTHER RESOURCES "AS IS" AND WITH ALL FAULTS, AND DISCLAIMS ALL WARRANTIES, EXPRESS AND IMPLIED, INCLUDING WITHOUT LIMITATION ANY IMPLIED WARRANTIES OF MERCHANTABILITY, FITNESS FOR A PARTICULAR PURPOSE OR NON-INFRINGEMENT OF THIRD PARTY INTELLECTUAL PROPERTY RIGHTS.

These resources are intended for skilled developers designing with TI products. You are solely responsible for (1) selecting the appropriate TI products for your application, (2) designing, validating and testing your application, and (3) ensuring your application meets applicable standards, and any other safety, security, or other requirements. These resources are subject to change without notice. TI grants you permission to use these resources only for development of an application that uses the TI products described in the resource. Other reproduction and display of these resources is prohibited. No license is granted to any other TI intellectual property right or to any third party intellectual property right. TI disclaims responsibility for, and you will fully indemnify TI and its representatives against, any claims, damages, costs, losses, and liabilities arising out of your use of these resources.

TI's products are provided subject to TI's Terms of Sale ([www.ti.com/legal/termsofsale.html](http://www.ti.com/legal/termsofsale.html)) or other applicable terms available either on [ti.com](http://ti.com) or provided in conjunction with such TI products. TI's provision of these resources does not expand or otherwise alter TI's applicable warranties or warranty disclaimers for TI products.

Mailing Address: Texas Instruments, Post Office Box 655303, Dallas, Texas 75265  
Copyright © 2020, Texas Instruments Incorporated