

TO-92L Plastic-Encapsulate Transistors

2SB892 TRANSISTOR (PNP)

FEATURE

- Power Supplies, Relay Drivers, Lamp Drivers, and Automotive Wiring
- Low Saturation Voltage.
- Large Current Capacity and Wide ASO.

TO-92L

1. EMITTER

2. COLLECTOR

3. BASE

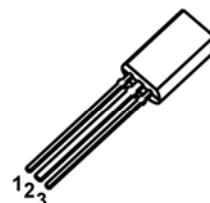

MAXIMUM RATINGS ($T_a=25^{\circ}\text{C}$ unless otherwise noted)

Symbol	Parameter	Value	Unit
V_{CB0}	Collector-Base Voltage	-60	V
V_{CEO}	Collector-Emitter Voltage	-50	V
V_{EBO}	Emitter-Base Voltage	-6	V
I_C	Collector Current -Continuous	-2	A
P_C	Collector Dissipation	0.75	W
T_J	Junction Temperature	150	$^{\circ}\text{C}$
T_{stg}	Storage Temperature	-55-150	$^{\circ}\text{C}$

ELECTRICAL CHARACTERISTICS ($T_a=25^{\circ}\text{C}$ unless otherwise specified)

Parameter	Symbol	Test conditions	Min	Max	Unit
Collector-base breakdown voltage	$V(BR)_{CB0}$	$I_C = -100\mu\text{A}$, $I_E = 0$	-60		V
Collector-emitter breakdown voltage	$V(BR)_{CEO}$	$I_C = -1\text{mA}$, $I_B = 0$	-50		V
Emitter-base breakdown voltage	$V(BR)_{EBO}$	$I_E = -100\mu\text{A}$, $I_C = 0$	-6		V
Collector cut-off current	I_{CB0}	$V_{CB} = -50\text{V}$, $I_E = 0$		-0.1	μA
Emitter cut-off current	I_{EBO}	$V_{EB} = -4\text{V}$, $I_C = 0$		-0.1	μA
DC current gain	$h_{FE(1)}$	$V_{CE} = -2\text{V}$, $I_C = -100\text{mA}$	100	560	
	$h_{FE(2)}$	$V_{CE} = -2\text{V}$, $I_C = -1.5\text{A}$	40		
Collector-emitter saturation voltage	$V_{CE(sat)}$	$I_C = -1\text{A}$, $I_B = -50\text{mA}$		-0.4	V
Base-emitter saturation voltage	$V_{BE(sat)}$	$I_C = -1\text{A}$, $I_B = -50\text{mA}$		-1.2	V
Transition frequency	f_T	$V_{CE} = -10\text{V}$, $I_C = -50\text{mA}$	150		MHz

CLASSIFICATION OF $h_{FE(1)}$

Rank	R	S	T	U
Range	100-200	140-280	200-400	280-560

Typical Characteristics

Static Characteristic

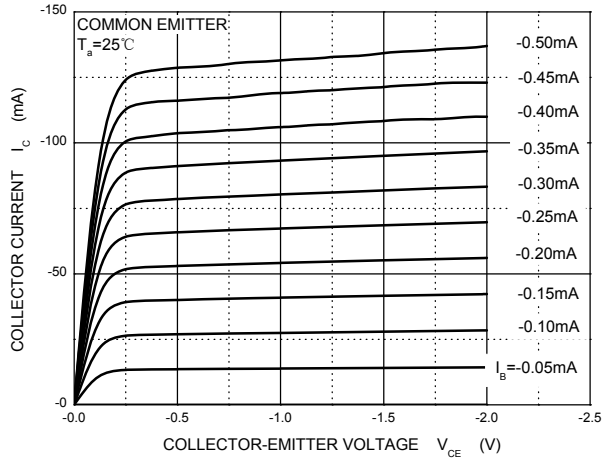

h_{FE} — I_c

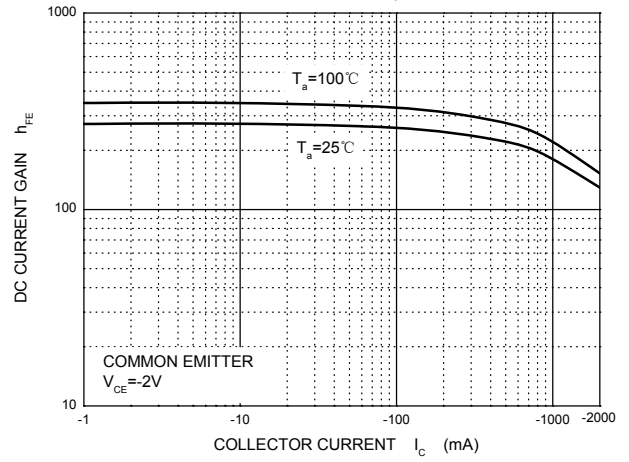

V_{CEsat} — I_c

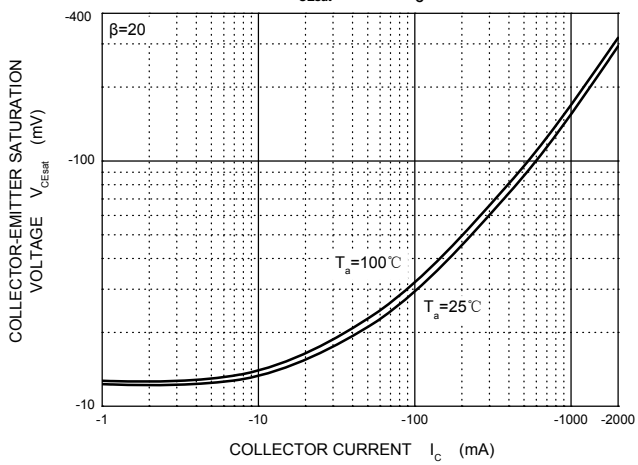

V_{BEsat} — I_c

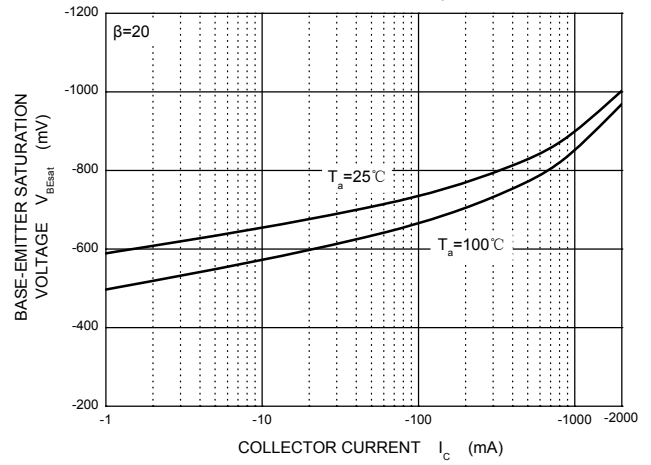

I_c — V_{BE}

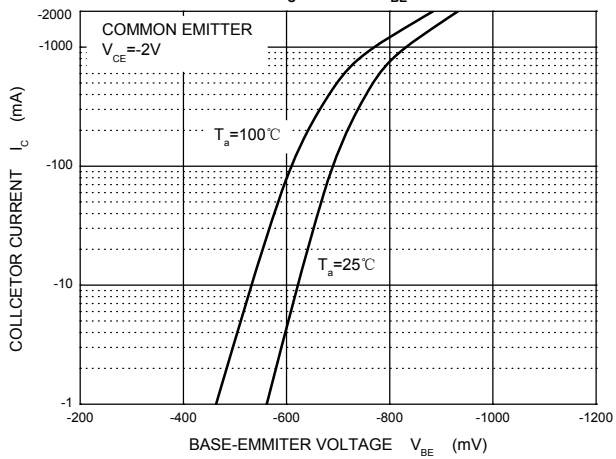

C_{ob}/C_{ib} — V_{CB}/V_{EB}

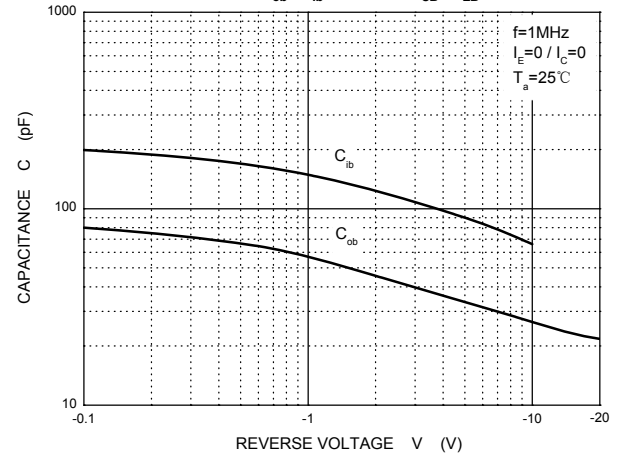

f_T — I_c

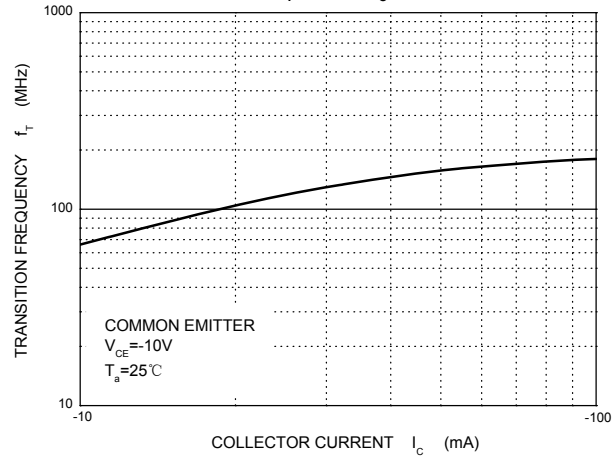

P_c — T_a

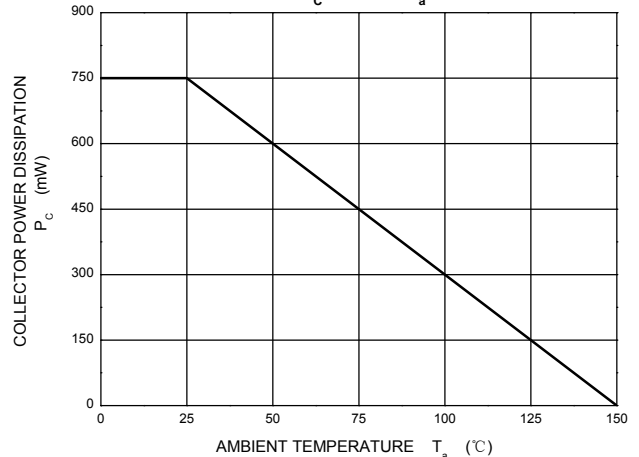

TO-92L Package Outline Dimensions

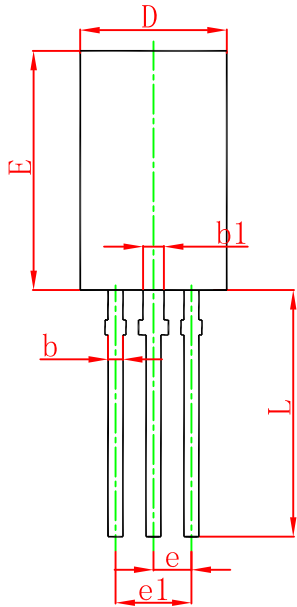
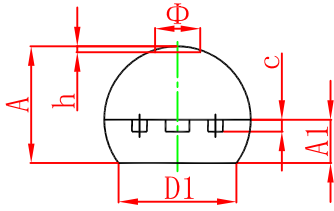

Symbol	Dimensions In Millimeters		Dimensions In Inches	
	Min.	Max.	Min.	Max.
A	3.750	4.050	0.148	0.159
A1	1.280	1.580	0.050	0.062
b	0.380	0.550	0.015	0.022
b1	0.620	0.780	0.024	0.031
c	0.350	0.450	0.014	0.018
D	4.750	5.050	0.187	0.199
D1	4.000		0.157	
E	7.850	8.150	0.309	0.321
e	1.270 TYP.		0.050 TYP.	
e1	2.440	2.640	0.096	0.104
L	13.800	14.200	0.543	0.559
Φ		1.600		0.063
h	0.000	0.300	0.000	0.012

TO-92L Suggested Pad Layout

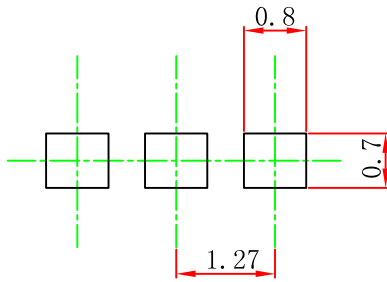

Note:

1. Controlling dimension: in millimeters.
2. General tolerance: $\pm 0.05\text{mm}$.
3. The pad layout is for reference purposes only.

NOTICE

JCET reserve the right to make modifications, enhancements, improvements, corrections or other changes without further notice to any product herein. JCET does not assume any liability arising out of the application or use of any product described herein.

TO-92L PACKAGE TAPING DIMENSION

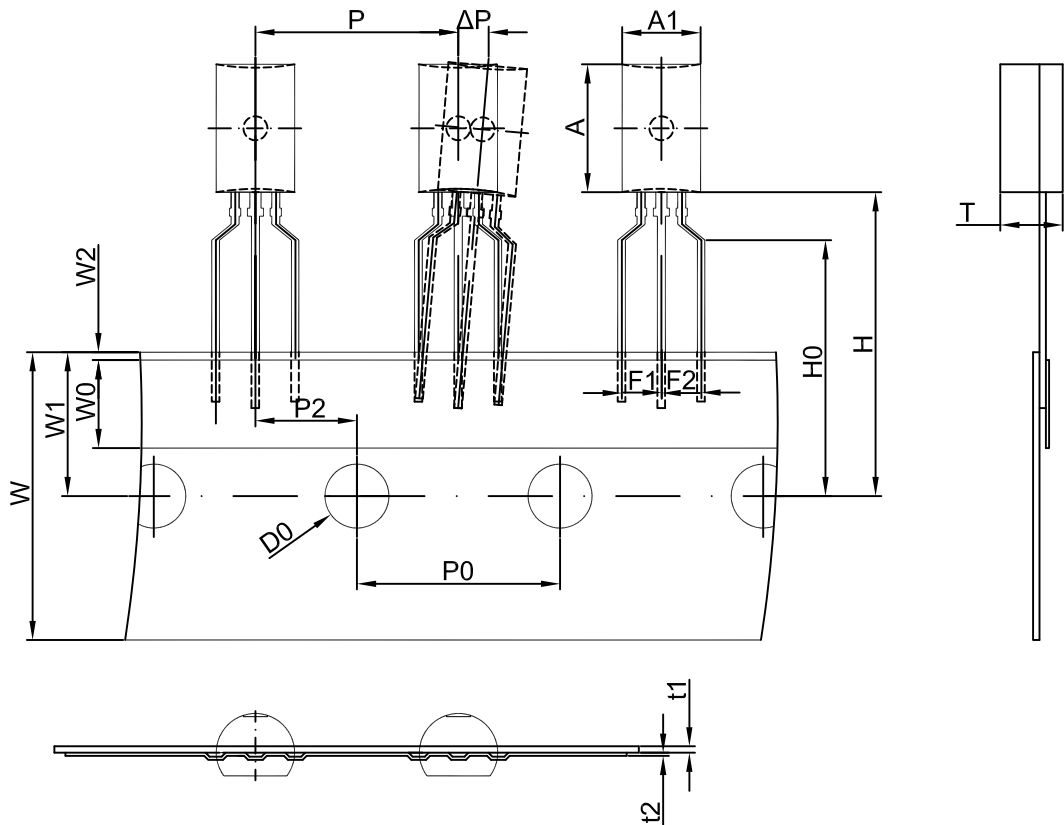

Dimensions are in millimeter

A1	A	T	P	P0	P2	F1	F2	W
4.9	8.0	3.9	12.7	12.7	6.35	2.5	2.5	18.0
W0	W1	W2	H	H0	D0	t1	t2	ΔP
6.0	9.0	1.0	19.0	16.0	4.0	0.4	0.2	0

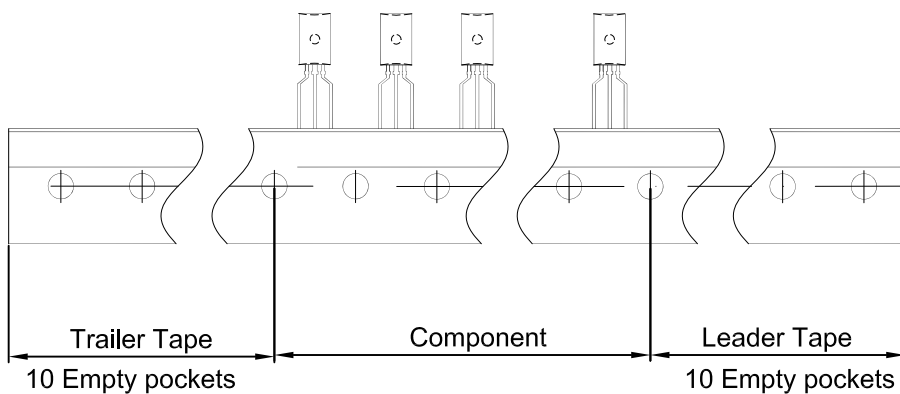

Package	Box	Box Size(mm)	Carton	Carton Size(mm)
TO-92L	2000 pcs	333×203×42	20,000 pcs	493×400×264