

GD54/74HC373, GD54/74HCT373

OCTAL 3-STATE NONINVERTING D-TYPE TRANSPARENT LATCHES

General Description

These devices are identical in pinout to the 54/74LS374. They contain eight D-type master/slave flip-flops with a common clock and clear. Data meeting the setup and hold time requirements are transferred to the 3-state outputs on the rising edge of the clock pulse. The output enable input does not affect the states of the flip-flops, but when output enable is high, the outputs are forced to the device is not selected. The HC/HCT 373 are identical in function to the HC/HCT 573 which have the input pins on the opposite side of the package from the output pins. They are similar in function to the HC/HCT 533 which have inverting outputs. These devices are characterized for operation over wide temperature ranges to meet industry and military specifications.

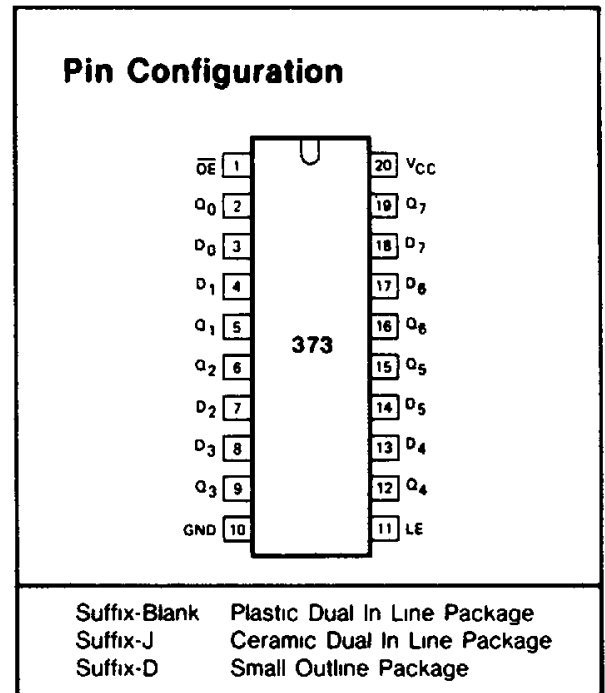

Features

- Low Power consumption characteristic of CMOS devices
- Output drive capability: 15 LS TTL Loads Min.
- Operating speed superior to LS TTL
- Wide operating voltage range: for HC 2 to 6 volts
for HCT 4.5 to 5.5 volts
- Low input current: 1μA Max.
- Low quiescent current: 80μA Max. (74HC)
- High noise immunity characteristic of CMOS
- Diode protection on all inputs

Function Table

OPERATING MODES	INPUTS			INTERNAL LATCHES	OUTPUTS Q ₀ to Q ₇
	OE	LE	D _n		
enable and read register (transparent mode)	L	H	L	L	L
	L	H	H	H	H
latch and read register	L	L	l	L	L
	L	L	h	H	H
latch register and disable outputs	H	L	l	L	Z
	H	L	h	H	Z

H = HIGH voltage level
h = HIGH voltage level one set-up time prior to the HIGH-to-LOW LE transition
L = LOW voltage level
l = LOW voltage level one set-up time prior to the HIGH-to-LOW LE transition
Z = high impedance OFF-state

GD54/74HC373, GD54/74HCT373

Absolute Maximum Ratings

SYMBOL	PARAMETER	CONDITIONS	MIN	MAX	UNIT
V_{CC}	DC Supply voltage		-0.5	+7	V
I_{IK}, I_{OK}	DC input or output diode current	for $V_I < -0.5$ or $V_I > V_{CC} + 0.5$ V		20	mA
I_O	DC output source or sink current	for -0.5 V $< V_O < V_{CC} + 0.5$ V		35	mA
I_{CC}	DC V_{CC} or GND current			70	mA
T_{stg}	Storage temperature range		-65	150	°C
P_D	Power dissipation per package	above +70°C derate linearly with 8mW/K		500	mW
T_L	Lead temperature	At distance $1/16 \pm 1/32$ in from case for 60 sec(CERAMIC) 10 sec(PLASTIC)		300 260	°C

Recommended Operating Conditions

CHARACTERISTIC	LIMITS		UNITS	
	MIN	MAX		
Supply-Voltage Range V_{CC}	GD54/74HC Types GD54/74HCT Types	2 4.5	6 5.5	V
DC Input or Output Voltage V_I, V_O		0	V_{CC}	V
Operating Temperature T_A	GD74 Types GD54 Types	-40 -55	+85 +125	°C
Input Rise and Fall times t_r, t_f	GD54/74HC Types at 2V at 4.5V at 6V GD54/74HCT Types at 4.5V		1000 500 400 500	ns

Logic Diagram

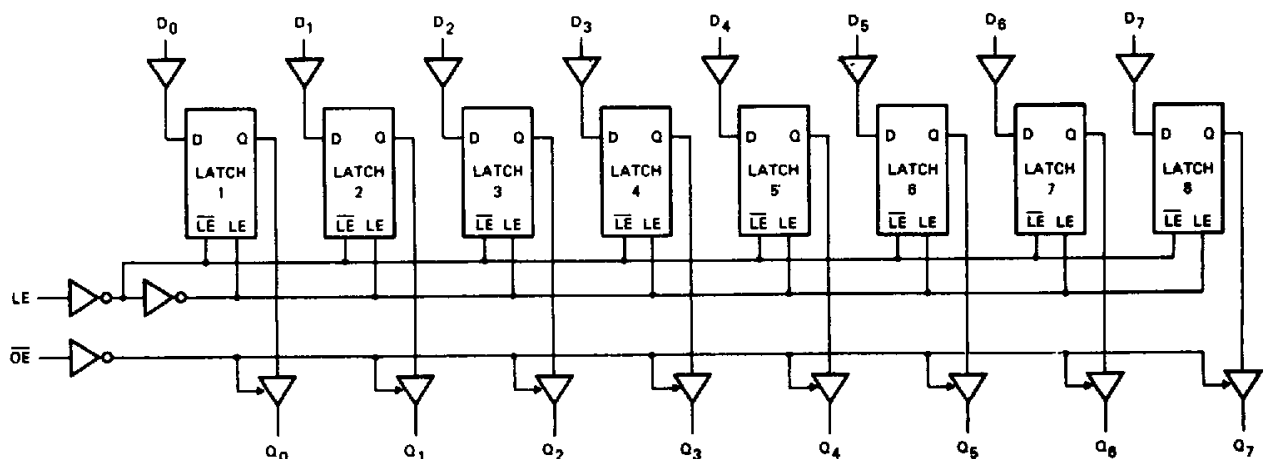

Fig. 1 Logic diagram.

GD54/74HC373, GD54/74HCT373

DC Electrical Characteristics for HC

SYMBOL	PARAMETER	TEST CONDITION	V _{CC} (V)	T _A =25°C			GD74HC373		GD54HC373		UNIT	
				MIN	TYP	MAX	MIN	MAX	MIN	MAX		
V _{IH}	HIGH level input Voltage		2.0	1.5			1.5		1.5		V	
			4.5	3.15			3.15		3.15			
			6.0	4.2			4.2		4.2			
V _{IL}	LOW level input voltage		2.0			0.3		0.3		0.3	V	
			4.5			0.9		0.9		0.9		
			6.0			1.2		1.2		1.2		
V _{OH}	HIGH level output voltage	V _{IN} =V _{IH} or V _{IL}	I _{OH} = -20μA	2.0	1.9	2.0		1.9		1.9	V	
				4.5	4.4	4.5		4.4		4.4		
			6.0	5.9	6.0		5.9		5.9			
V _{OL}	LOW level output voltage	V _{IN} =V _{IH} or V _{IL}	I _{OL} = 20μA	2.0			0.1		0.1		0.1	V
				4.5			0.1		0.1		0.1	
			6.0			0.1		0.1		0.1		
V _{OL}	LOW level output voltage	V _{IN} =V _{IH} or V _{IL}	I _{OL} = 6mA	4.5		0.17	0.26		0.33		0.4	V
				6.0		0.15	0.26		0.33		0.4	
			I _{OL} = 7.8mA	4.5								
I _{IN}	Input leakage Current	V _{IN} =V _{CC} or GND	6.0			0.1		1.0		1.0	μA	
I _{OZ}	Three State leakage current	V _{IN} =V _{IH} or V _{IL} V _O =V _{CC} or GND	6.0		0.01	0.5		5.0		10.0	μA	
I _{CC}	Quiescent Supply Current	V _{IN} =V _{CC} or GND I _{out} =0μA	6.0			8		80		160	μA	

DC Electrical Characteristics for HCT

SYMBOL	PARAMETER	TEST CONDITION	V _{CC} (V)	T _A =25°C			GD74HCT373		GD54HCT373		UNIT	
				MIN	TYP	MAX	MIN	MAX	MIN	MAX		
V _{IH}	HIGH level input Voltage		4.5 to 5.0	2.0			2.0		2.0		V	
V _{IL}	LOW level input voltage		4.5 to 5.5			0.8		0.8		0.8	V	
V _{OH}	HIGH level output voltage	V _{IN} =V _{IH} or V _{IL}	I _{OH} = -20μA	4.5	4.4	4.5		4.4		4.4	V	
			I _{OH} = -6mA	4.5	3.98	4.3		3.84		3.7		
V _{OL}	LOW level output voltage	V _{IN} =V _{IH} or V _{IL}	I _{OL} = 20μA	4.5			0.1		0.1		0.1	V
			I _{OL} = 6mA	4.5			0.17	0.26		0.33		
I _{IN}	Input leakage Current	V _{IN} =V _{CC} or GND	5.5			0.1		1.0		1.0	μA	
I _{OZ}	Three-State leakage current	V _{IN} =V _{IH} or V _{IL} V _O =V _{CC} or GND	5.5		0.01	0.5		5.0		10.0	μA	
I _{CC}	Quiescent Supply Current	V _{IN} =V _{CC} or GND I _{out} =0μA	5.5			8		80		160	μA	

GD54/74HC373, GD54/74HCT373

Timing Requirement for HC: $t_r=t_f=6\text{ns}$ $C_L=50\text{ pF}$

SYMBOL	PARAMETER		V_{CC} (V)	$T_A=25^\circ\text{C}$			GD74HC373		GD54HC373		UNIT
				MIN	TYP	MAX	MIN	MAX	MIN	MAX	
t_w	Pulse width	LE high	2.0	80	30		100		120		ns
			4.5	16	10		20		25		
			6.0	14	8		18		22		
t_{su}	Setup time	Data before LE ↓	2.0	60	30		100		120		ns
			4.5	12	10		20		25		
			6.0	10	8		18		22		
t_h	Hold time	Data after LE ↓	2.0	3	0		3		3		ns
			4.5	3	0		3		3		
			6.0	3	0		3		3		

AC Characteristics for HC: $t_r=t_f=6\text{ns}$ $C_L=50\text{ pF}$

SYMBOL	PARAMETER		V_{CC} (V)	$T_A=25^\circ\text{C}$			GD74HC373		GD54HC373		UNIT
				MIN	TYP	MAX	MIN	MAX	MIN	MAX	
$t_{PLH}/$ t_{PHL}	Propagation Delay Time Dn to Qn		2.0		40	140		180		210	ns
			4.5		14	28		36		40	
			6.0		12	26		33		38	
$t_{PLH}/$ t_{PHL}	Propagation Delay Time LE to Qn		2.0		42	150		190		220	ns
			4.5		16	32		42		50	
			6.0		14	30		38		45	
$t_{PZH}/$ t_{PZL}	3-state Output Enable Time \overline{OE} to Q_n		2.0		45	150		190		220	ns
			4.5		15	30		38		45	
			6.0		14	26		33		38	
$t_{PLZ}/$ t_{PHZ}	3-state Output Disable Time \overline{OE} to Q_n		2.0		45	150		190		220	ns
			4.5		15	30		38		45	
			6.0		14	26		33		38	
$t_{TLH}/$ t_{THL}	Output Transition Time		2.0		15	60		75		90	ns
			4.5		6	12		15		18	
			6.0		5	10		13		15	

GD54/74HC373, GD54/74HCT373

Timing Requirements for HCT: $t_r=t_f=6\text{ns}$ $C_L=50\text{ pF}$

SYMBOL	PARAMETER		V_{CC} (V)	$T_A=25^\circ\text{C}$			GD74HCT373		GD54HCT373		UNIT
				MIN.	TYP.	MAX.	MIN.	MAX.	MIN.	MAX.	
t_w	Pulse width	LE high	4.5	16	10		20		25	ns	
t_{su}	Setup time	Data after LE ↓	4.5	12	10		20		25	ns	
t_h	Hold time	Data before LE ↓	4.5	3	0		3		3	ns	

AC Characteristics for HCT: $t_r=t_f=6\text{ns}$ $C_L=50\text{ pF}$

SYMBOL	PARAMETER		V_{CC} (V)	$T_A=25^\circ\text{C}$			GD74HCT373		GD54HCT373		UNIT
				MIN.	TYP.	MAX.	MIN.	MAX.	MIN.	MAX.	
t_{PLH} t_{PHL}	Propagation Delay Time D_n to Q_n		4.5		16	30		38		44	ns
$t_{PLH}/$ t_{PHL}	Propagation Delay Time LE to Q_n		4.5		19	35		42		48	ns
$t_{PZH}/$ t_{PZL}	3-state Output Enable time \overline{OE} to Q_n		4.5		15	30		38		45	ns
t_{PLZ} t_{PHZ}	3-state Output Disable Time \overline{OE} to Q_n		4.5		15	30		38		45	ns
$t_{TLH}/$ t_{THL}	Output Transition Time		4.5		6	12		15		18	ns

AC Waveforms

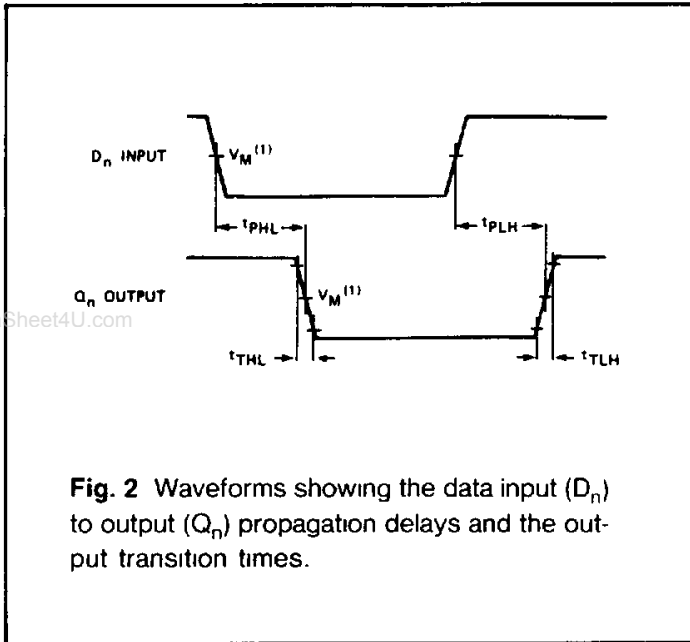

Fig. 2 Waveforms showing the data input (D_n) to output (Q_n) propagation delays and the output transition times.

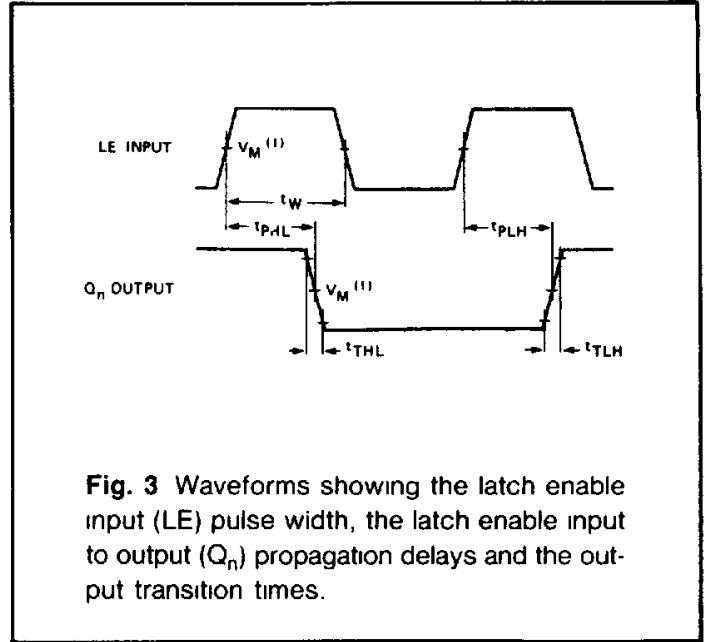

Fig. 3 Waveforms showing the latch enable input (LE) pulse width, the latch enable input to output (Q_n) propagation delays and the output transition times.

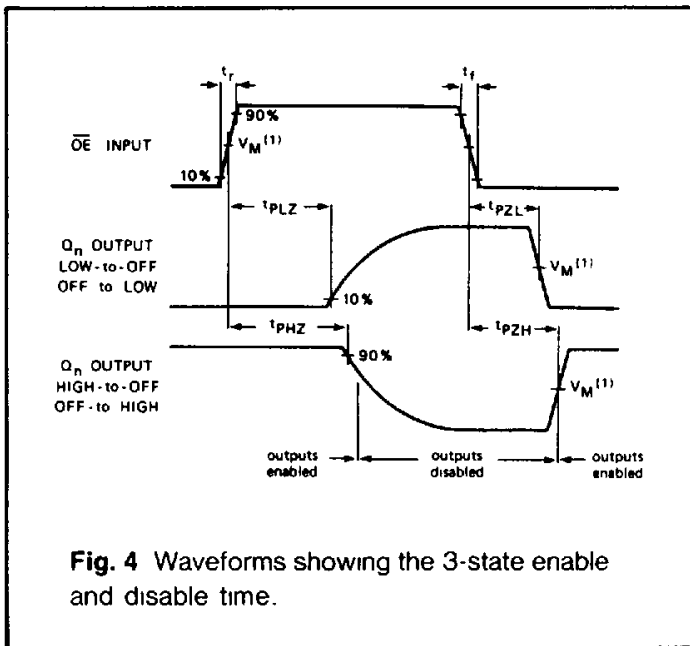

Fig. 4 Waveforms showing the 3-state enable and disable time.

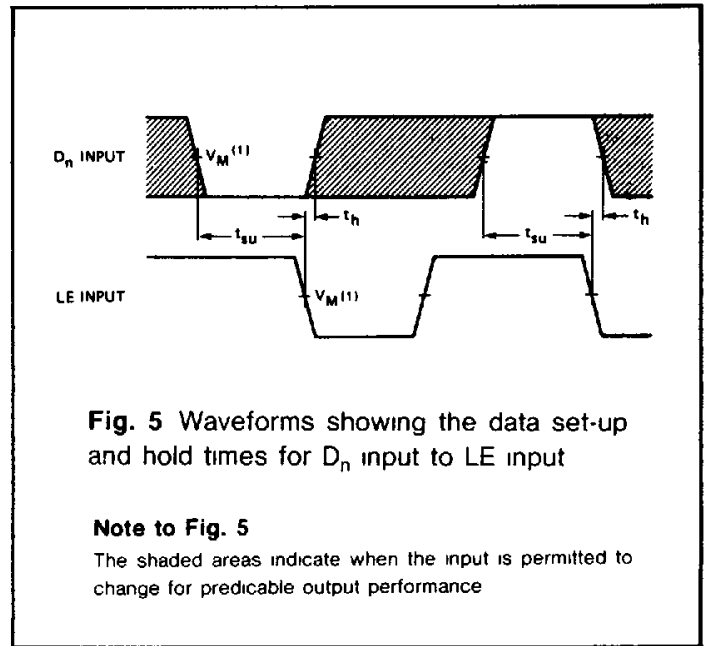

Fig. 5 Waveforms showing the data set-up and hold times for D_n input to LE input

Note to Fig. 5

The shaded areas indicate when the input is permitted to change for predicable output performance

Note to AC waveforms

- (1) HC $V_M=50\%$ $V_I=GND$ to V_{CC}
- HCT $V_M=1.3V$, $V_I=GND$ to $3V$