

Silicon PNP Power Transistors

2SB1334

DESCRIPTION

- With TO-220 package
- Complement to type 2SD1778
- Wide area of safe operation
- Low collector saturation voltage

APPLICATIONS

- Designed for use in low frequency power amplifier applications

PINNING

PIN	DESCRIPTION
1	Emitter
2	Collector;connected to mounting base
3	Base

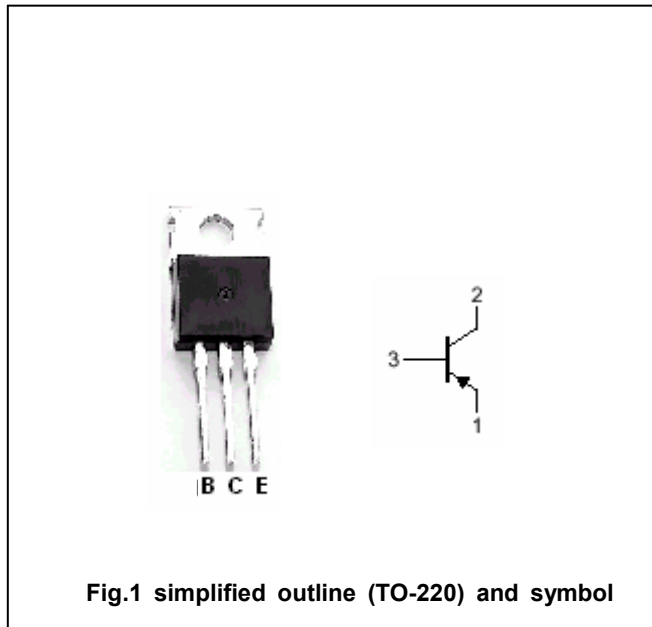

Absolute maximum ratings(Ta=25°C)

SYMBOL	PARAMETER	CONDITIONS	VALUE	UNIT
V _{CBO}	Collector-base voltage	Open emitter	-80	V
V _{CEO}	Collector-emitter voltage	Open base	-60	V
V _{EBO}	Emitter-base voltage	Open collector	-5	V
I _C	Collector current		-4	A
I _{CM}	Collector current-peak		-6	A
P _C	Collector power dissipation	T _C =25°C	40	W
T _j	Junction temperature		150	°C
T _{stg}	Storage temperature		-55~150	°C

Silicon PNP Power Transistors

2SB1334

CHARACTERISTICS

T_j=25°C unless otherwise specified

SYMBOL	PARAMETER	CONDITIONS	MIN	TYP.	MAX	UNIT
V _{(BR)CEO}	Collector-emitter breakdown voltage	I _C =-1mA, I _B =0	-60			V
V _{(BR)CBO}	Collector-base breakdown voltage	I _C =-50μA, I _E =0	-80			V
V _{(BR)EBO}	Emitter-base breakdown voltage	I _E =-50μA, I _C =0	-5			V
V _{CEsat}	Collector-emitter saturation voltage	I _C =-3A; I _B =-0.3A			-1.5	V
V _{BEsat}	Base-emitter saturation voltage	I _C =-3A; I _B =-0.3A			-1.5	V
I _{CBO}	Collector cut-off current	V _{CB} =-80V; I _E =0			-10	μA
I _{EBO}	Emitter cut-off current	V _{EB} =-4V; I _C =0			-10	μA
h _{FE}	DC current gain	I _C =-1A; V _{CE} =-5V	60		320	
C _{OB}	Output capacitance	I _E =0; V _{CB} =-10V, f=1MHz		100		pF
f _T	Transition frequency	I _E =0.5A; V _{CE} =-5V		12		MHz

◆ h_{FE} Classifications

D	E	F
60-120	100-200	160-320

Silicon PNP Power Transistors

2SB1334

PACKAGE OUTLINE

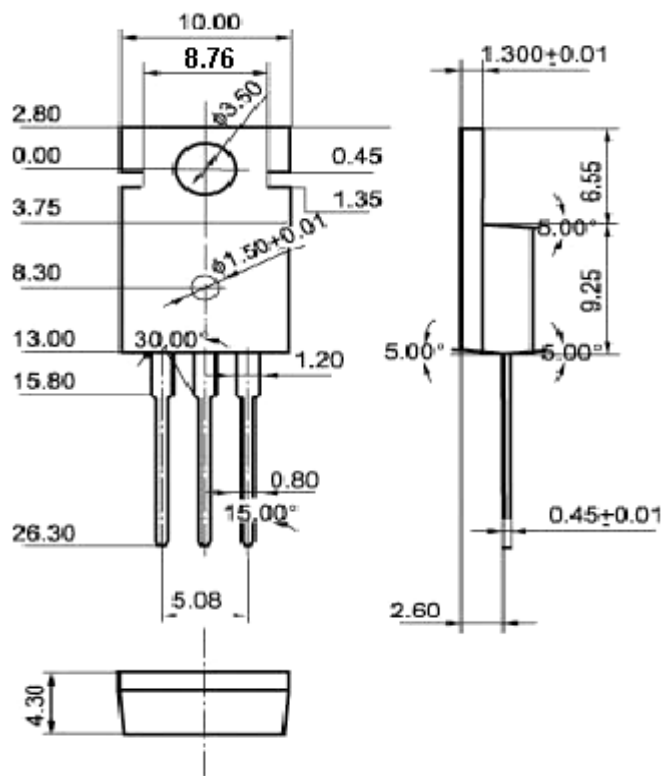

Fig.2 Outline dimensions(unindicated tolerance:±0.10 mm)