

74LVC595A

8-bit serial-in/serial-out or parallel-out shift register; 3-state

Rev. 2 — 20 June 2014

Product data sheet

1. General description

The 74LVC595A is an 8-bit serial-in/serial or parallel-out shift register with a storage register and 3-state outputs. Both the shift and storage register have separate clocks.

The input can be driven from either 3.3 V or 5 V devices. This feature allows the use of this device in a mixed 3.3 V and 5 V environment.

This device is fully specified for partial Power-down applications using I_{OFF} . The I_{OFF} circuitry disables the output, preventing the damaging backflow current through the device when it is powered down.

Data is shifted on the positive-going transitions of the SHCP input. The data in the shift register is transferred to the storage register on a positive-going transition of the STCP input. If both clocks are connected together, the shift register will always be one clock pulse ahead of the storage register.

The shift register has a serial input (DS) and a serial output ($Q7S$) for cascading purposes. It is also provided with asynchronous reset input \overline{MR} (active LOW) for all 8 shift register stages. The storage register has 8 parallel 3-state bus driver outputs. Data in the storage register appears at the output whenever the output enable input (\overline{OE}) is LOW.

2. Features and benefits

- 5 V tolerant inputs/outputs for interfacing with 5 V logic
- Wide supply voltage range from 1.2 V to 3.6 V
- CMOS low-power consumption
- Direct interface with TTL levels
- Balanced propagation delays
- All inputs have Schmitt-trigger action
- Complies with JEDEC standard JESD8-B/JESD36
- ESD protection:
 - ◆ HBM JESD22-A114-D exceeds 2000 V
 - ◆ CDM JESD22-C101-C exceeds 1000 V
- Specified from $-40\text{ }^{\circ}\text{C}$ to $+85\text{ }^{\circ}\text{C}$ and $-40\text{ }^{\circ}\text{C}$ to $+125\text{ }^{\circ}\text{C}$.

3. Applications

- Serial-to-parallel data conversion
- Remote control holding register

4. Ordering information

Table 1. Ordering information

Type number	Package			Version
	Temperature range	Name	Description	
74LVC595AD	-40 °C to +125 °C	SO16	plastic small outline package; 16 leads; body width 3.9 mm	SOT109-1
74LVC595APW	-40 °C to +125 °C	TSSOP16	plastic thin shrink small outline package; 16 leads; body width 4.4 mm	SOT403-1
74LVC595ABQ	-40 °C to +125 °C	DHVQFN16	plastic dual in-line compatible thermal enhanced very thin quad flat package; no leads; 16 terminals; body 2.5 × 3.5 × 0.85 mm	SOT763-1

5. Functional diagram

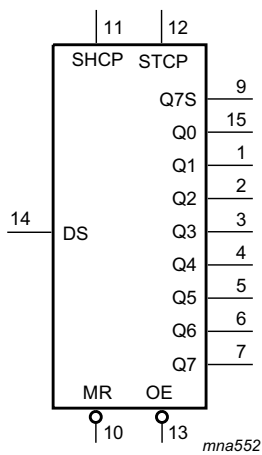

Fig 1. Logic symbol

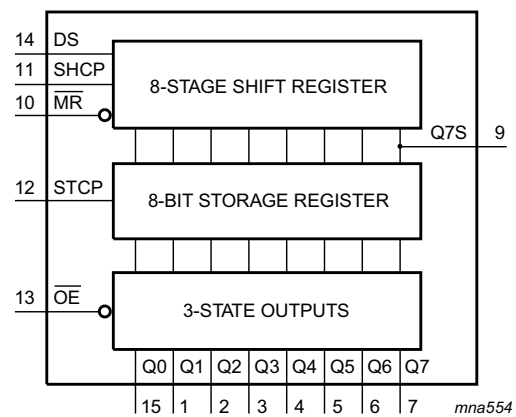

Fig 2. Functional diagram

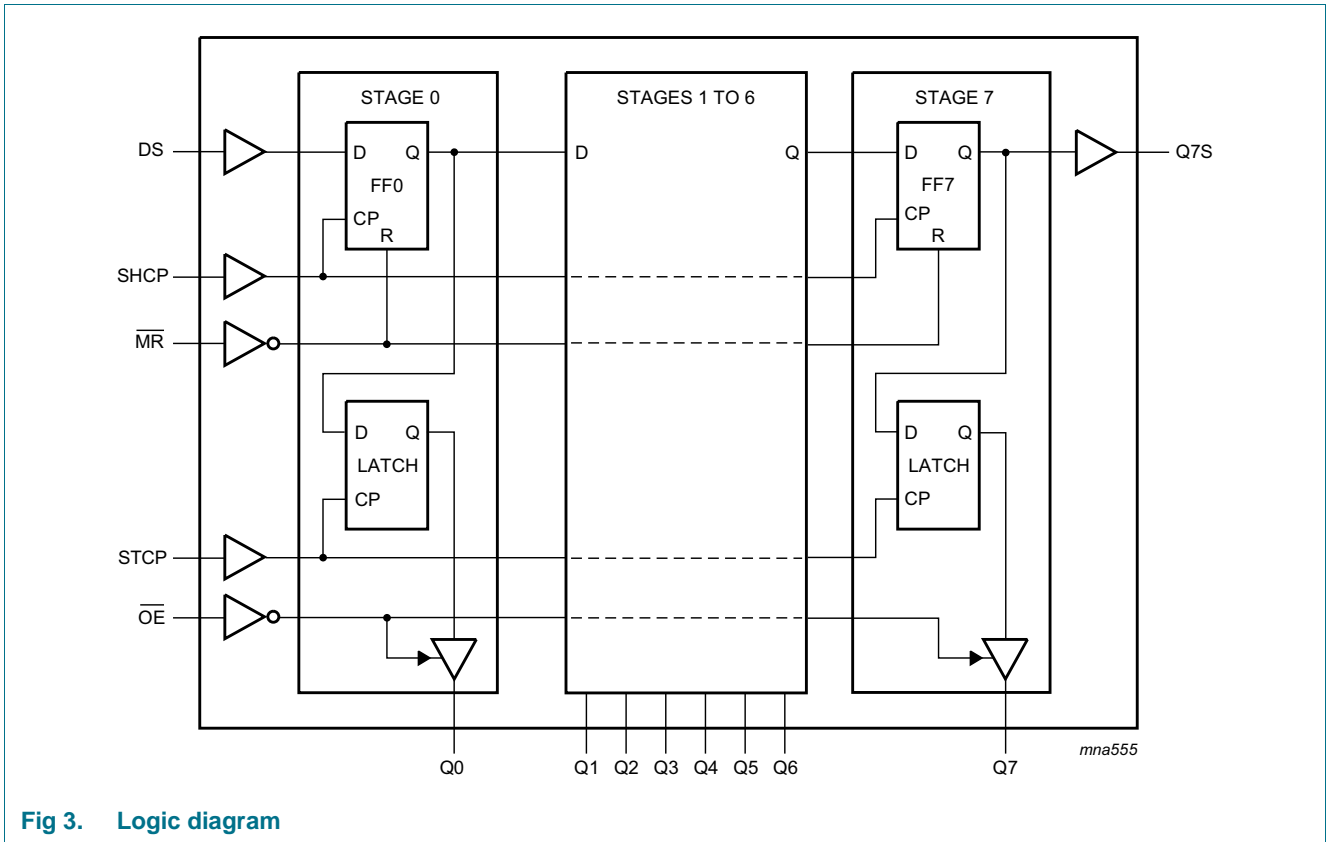

Fig 3. Logic diagram

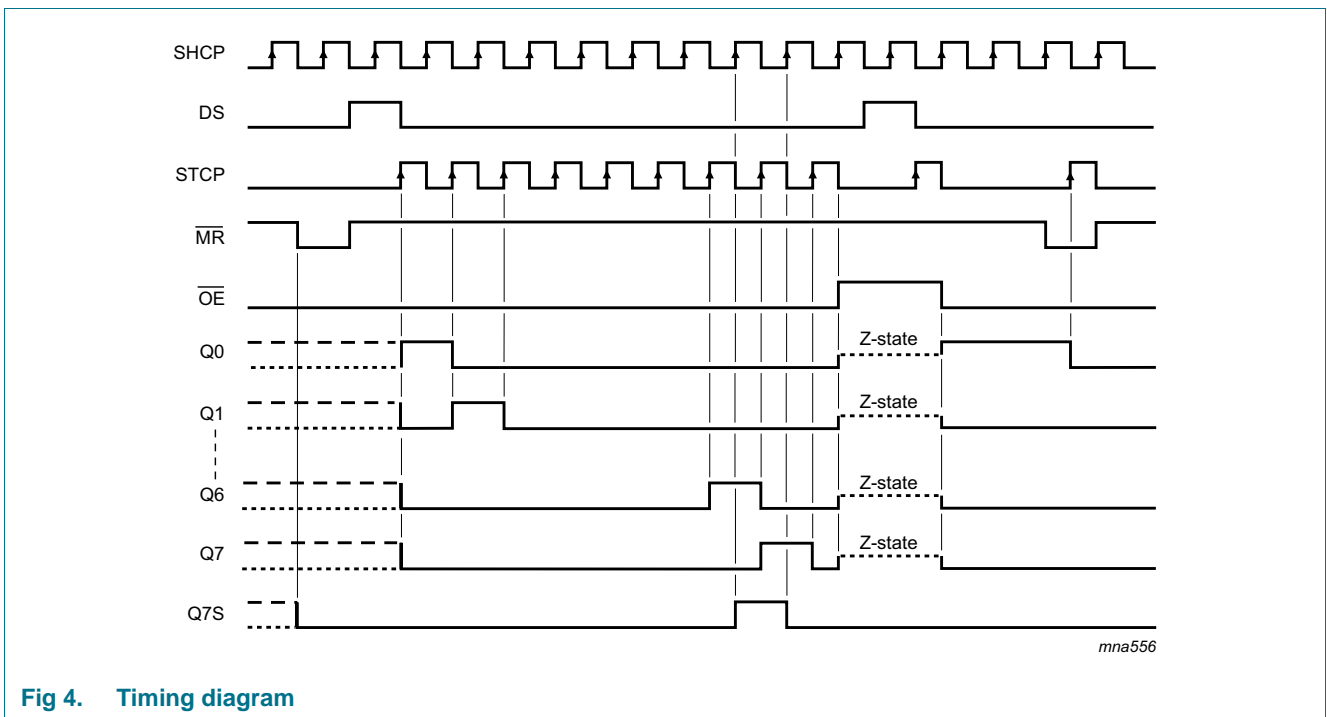
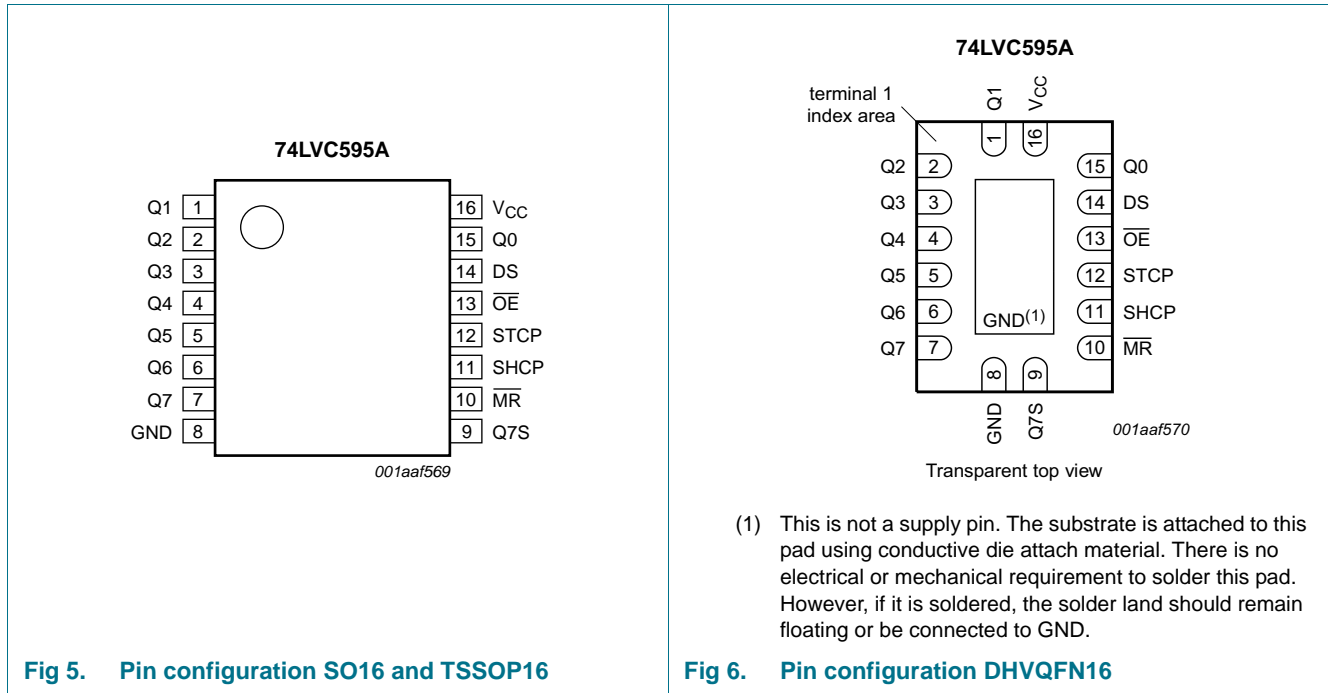

Fig 4. Timing diagram

6. Pinning information

6.1 Pinning



6.2 Pin description

Table 2. Pin description

Symbol	Pin	Description
Q[0:7]	15, 1, 2, 3, 4, 5, 6, 7	parallel data output
GND	8	ground (0 V)
Q7S	9	serial data output
MR	10	master reset (active LOW)
SHCP	11	shift register clock input
STCP	12	storage register clock input
OE	13	output enable input (active LOW)
DS	14	serial data input
V _{CC}	16	supply voltage

7. Functional description

Table 3. Function table^[1]

Input					Output		Function
SHCP	STCP	\overline{OE}	\overline{MR}	DS	Q7S	Qn	
X	X	L	L	X	L	NC	a LOW-state on \overline{MR} only affects the shift register
X	↑	L	L	X	L	L	empty shift register loaded into storage register
X	X	H	L	X	L	Z	shift register clear; parallel outputs in high impedance OFF-state
↑	X	L	H	H	Q6S	NC	logic HIGH-state shifted into shift register stage 0. Contents of all shift register stages shifted through, e.g. previous state of stage 6 (internal Q6S) appears on the serial output (Q7S).
X	↑	L	H	X	NC	QnS	contents of shift register stages (internal QnS) are transferred to the storage register and parallel output stages
↑	↑	L	H	X	Q6S	QnS	contents of shift register shifted through; previous contents of the shift register is transferred to the storage register and the parallel output stages

- [1] H = HIGH voltage state;
 L = LOW voltage state;
 ↑ = LOW-to-HIGH transition;
 X = don't care;
 NC = no change;
 Z = high-impedance OFF-state.

8. Limiting values

Table 4. Limiting values

In accordance with the Absolute Maximum Rating System (IEC 60134). Voltages are referenced to GND (ground = 0 V).

Symbol	Parameter	Conditions	Min	Max	Unit
V_{CC}	supply voltage		-0.5	+6.5	V
I_{IK}	input clamping current	$V_I < 0$ V	-50	-	mA
V_I	input voltage		[1] -0.5	+6.5	V
I_{OK}	output clamping current	$V_O > V_{CC}$ or $V_O < 0$ V	-	±50	mA
V_O	output voltage	3-state	[1] -0.5	6.5	V
		output HIGH or LOW state	[1] -0.5	$V_{CC} + 0.5$	V
I_O	output current	$V_O = 0$ V to V_{CC}	-	±50	mA
I_{CC}	supply current		-	100	mA
I_{GND}	ground current		-100	-	mA
T_{stg}	storage temperature		-65	+150	°C
P_{tot}	total power dissipation	$T_{amb} = -40$ °C to +125 °C	[2] -	500	mW

- [1] The input and output voltage ratings may be exceeded if the input and output current ratings are observed.
 [2] For SO16 packages: above 70 °C the value of P_{tot} derates linearly with 8 mW/K.
 For TSSOP16 packages: above 60 °C the value of P_{tot} derates linearly with 5.5 mW/K.
 For DHVQFN16 packages: above 60 °C the value of P_{tot} derates linearly with 4.5 mW/K.

9. Recommended operating conditions

Table 5. Recommended operating conditions

Symbol	Parameter	Conditions	Min	Typ	Max	Unit
V _{CC}	supply voltage		1.65	-	3.6	V
		functional	1.2	-	-	V
V _I	input voltage		0	-	5.5	V
V _O	output voltage	3-state	0	-	5.5	V
		output HIGH or LOW state	0	-	V _{CC}	V
T _{amb}	ambient temperature		-40	-	+125	°C
Δt/ΔV	input transition rise and fall rate	V _{CC} = 1.65 V to 2.7 V	0	-	20	ns/V
		V _{CC} = 2.7 V to 3.6 V	0	-	10	ns/V

10. Static characteristics

Table 6. Static characteristics

At recommended operating conditions. Voltages are referenced to GND (ground = 0 V).

Symbol	Parameter	Conditions	-40 °C to +85 °C			-40 °C to +125 °C		Unit
			Min	Typ ^[1]	Max	Min	Max	
V _{IH}	HIGH-level input voltage	V _{CC} = 1.2 V	1.08	-	-	1.08	-	V
		V _{CC} = 1.65 V to 1.95 V	0.65 × V _{CC}	-	-	0.65 × V _{CC}	-	V
		V _{CC} = 2.3 V to 2.7 V	1.7	-	-	1.7	-	V
		V _{CC} = 2.7 V to 3.6 V	2.0	-	-	2.0	-	V
V _{IL}	LOW-level input voltage	V _{CC} = 1.2 V	-	-	0.12	-	0.12	V
		V _{CC} = 1.65 V to 1.95 V	-	-	0.35 × V _{CC}	-	0.35 × V _{CC}	V
		V _{CC} = 2.3 V to 2.7 V	-	-	0.7	-	0.7	V
		V _{CC} = 2.7 V to 3.6 V	-	-	0.8	-	0.8	V
V _{OH}	HIGH-level output voltage	V _I = V _{IH} or V _{IL}						
		I _O = -100 μA; V _{CC} = 1.65 V to 3.6 V	V _{CC} - 0.2	-	-	V _{CC} - 0.3	-	V
		I _O = -4 mA; V _{CC} = 1.65 V	1.2	-	-	1.05	-	V
		I _O = -8 mA; V _{CC} = 2.3 V	1.8	-	-	1.65	-	V
		I _O = -12 mA; V _{CC} = 2.7 V	2.2	-	-	2.05	-	V
		I _O = -18 mA; V _{CC} = 3.0 V	2.4	-	-	2.25	-	V
		I _O = -24 mA; V _{CC} = 3.0 V	2.2	-	-	2.0	-	V
V _{OL}	LOW-level output voltage	V _I = V _{IH} or V _{IL}						
		I _O = 100 μA; V _{CC} = 1.65 V to 3.6 V	-	-	0.2	-	0.3	V
		I _O = 4 mA; V _{CC} = 1.65 V	-	-	0.45	-	0.65	V
		I _O = 8 mA; V _{CC} = 2.3 V	-	-	0.6	-	0.8	V
		I _O = 12 mA; V _{CC} = 2.7 V	-	-	0.4	-	0.6	V
		I _O = 24 mA; V _{CC} = 3.0 V	-	-	0.55	-	0.8	V
I _I	input leakage current	V _{CC} = 3.6 V; V _I = 5.5 V or GND	-	±0.1	±5	-	±20	μA

Table 6. Static characteristics ...continued

At recommended operating conditions. Voltages are referenced to GND (ground = 0 V).

Symbol	Parameter	Conditions	-40 °C to +85 °C			-40 °C to +125 °C		Unit
			Min	Typ ^[1]	Max	Min	Max	
I _{OZ}	OFF-state output current	V _I = V _{IH} or V _{IL} ; V _O = 5.5 V or GND; V _{CC} = 3.6 V ^[2]	-	0.1	±10	-	±20	µA
I _{OFF}	power-off leakage current	V _{CC} = 0 V; V _I or V _O = 5.5 V	-	0.1	10	-	20	µA
I _{CC}	supply current	V _{CC} = 3.6 V; V _I = V _{CC} or GND; I _O = 0 A	-	0.1	10	-	40	µA
ΔI _{CC}	additional supply current	per input pin; V _{CC} = 1.65 V to 3.6 V; V _I = V _{CC} - 0.6 V; I _O = 0 A	-	5	500	-	5000	µA
C _I	input capacitance	V _{CC} = 0 V to 3.6 V; V _I = GND to V _{CC}	-	5.0	-	-	-	pF

[1] All typical values are measured at V_{CC} = 3.3 V (unless stated otherwise) and T_{amb} = 25 °C.[2] For transceivers, the parameter I_{OZ} includes the input leaking current.

11. Dynamic characteristics

Table 7. Dynamic characteristicsVoltages are referenced to GND (ground = 0 V). For test circuit see [Figure 13](#).

Symbol	Parameter	Conditions	-40 °C to +85 °C			-40 °C to +125 °C		Unit
			Min	Typ ^[1]	Max	Min	Max	
t _{pd}	propagation delay	SHCP to Q7S; see Figure 7 ^[2]						
		V _{CC} = 1.2 V	-	17.5	-	-	-	ns
		V _{CC} = 1.65 V to 1.95 V	2.0	6.6	15.8	2.0	18.2	ns
		V _{CC} = 2.3 V to 2.7 V	1.5	4.2	8.1	1.5	9.3	ns
		V _{CC} = 2.7 V	1.5	4.7	7.6	1.5	8.7	ns
		V _{CC} = 3.0 V to 3.6 V	1.5	4.0	6.7	1.5	7.7	ns
		STCP to Qn; see Figure 8 ^[2]						
		V _{CC} = 1.2 V	-	16.8	-	-	-	ns
		V _{CC} = 1.65 V to 1.95 V	2.0	5.8	15.8	2.0	18.2	ns
		V _{CC} = 2.3 V to 2.7 V	1.5	3.7	8.1	1.5	9.3	ns
		V _{CC} = 2.7 V	1.5	4.0	7.6	1.5	8.7	ns
		V _{CC} = 3.0 V to 3.6 V	1.2	3.3	6.7	1.2	7.7	ns
t _{PHL}	HIGH to LOW propagation delay	MR to Q7S; see Figure 11						
		V _{CC} = 1.2 V	-	17.3	-	-	-	ns
		V _{CC} = 1.65 V to 1.95 V	2.0	6.9	15.8	2.0	18.2	ns
		V _{CC} = 2.3 V to 2.7 V	1.5	4.3	8.1	1.5	9.3	ns
		V _{CC} = 2.7 V	1.5	4.5	7.6	1.5	8.7	ns
		V _{CC} = 3.0 V to 3.6 V	1.2	3.8	6.7	1.2	7.7	ns

Table 7. Dynamic characteristics ...continuedVoltages are referenced to GND (ground = 0 V). For test circuit see [Figure 13](#).

Symbol	Parameter	Conditions	-40 °C to +85 °C			-40 °C to +125 °C		Unit
			Min	Typ ^[1]	Max	Min	Max	
t _{en}	enable time	\overline{OE} to Qn; see Figure 12 ^[3]						
		V _{CC} = 1.2 V	-	17.9	-	-	-	ns
		V _{CC} = 1.65 V to 1.95 V	2.0	6.4	14.1	2.0	16.2	ns
		V _{CC} = 2.3 V to 2.7 V	1.5	4.2	8.0	1.5	9.2	ns
		V _{CC} = 2.7 V	1.5	4.5	7.6	1.5	8.7	ns
		V _{CC} = 3.0 V to 3.6 V	1.2	3.8	6.7	1.2	7.7	ns
t _{dis}	disable time	\overline{OE} to Qn; see Figure 12 ^[4]						
		V _{CC} = 1.2 V	-	9.6	-	-	-	ns
		V _{CC} = 1.65 V to 1.95 V	2.0	4.9	9.8	2.0	11.2	ns
		V _{CC} = 2.3 V to 2.7 V	1.2	2.8	5.8	1.2	6.6	ns
		V _{CC} = 2.7 V	1.5	3.7	6.2	1.5	7.1	ns
		V _{CC} = 3.0 V to 3.6 V	1.2	3.5	5.7	1.2	6.5	ns
t _w	pulse width	SHCP, STCP HIGH or LOW; see Figure 7 and Figure 8						
		V _{CC} = 1.65 V to 1.95 V	6.0	2.5	-	7.0	-	ns
		V _{CC} = 2.3 V to 2.7 V	5.0	2.0	-	5.5	-	ns
		V _{CC} = 2.7 V	4.5	1.5	-	5.0	-	ns
		V _{CC} = 3.0 V to 3.6 V	4.0	1.5	-	4.5	-	ns
		\overline{MR} LOW; see Figure 11						
		V _{CC} = 1.65 V to 1.95 V	5.0	2.0	-	5.5	-	ns
		V _{CC} = 2.3 V to 2.7 V	4.0	1.5	-	4.5	-	ns
		V _{CC} = 2.7 V	2.5	1.0	-	3.0	-	ns
		V _{CC} = 3.0 V to 3.6 V	2.5	1.0	-	3.0	-	ns
t _{su}	set-up time	DS to SHCP; see Figure 9						
		V _{CC} = 1.65 V to 1.95 V	5.0	0.4	-	5.5	-	ns
		V _{CC} = 2.3 V to 2.7 V	4.0	0.1	-	4.5	-	ns
		V _{CC} = 2.7 V	2.0	0	-	2.5	-	ns
		V _{CC} = 3.0 V to 3.6 V	2.0	-0.1	-	2.5	-	ns
		\overline{MR} to STCP; see Figure 10						
		V _{CC} = 1.65 V to 1.95 V	8.0	3.5	-	8.5	-	ns
		V _{CC} = 2.3 V to 2.7 V	5.0	2.1	-	5.5	-	ns
		V _{CC} = 2.7 V	4.0	1.8	-	4.5	-	ns
		V _{CC} = 3.0 V to 3.6 V	4.0	1.7	-	4.5	-	ns
		SHCP to STCP; see Figure 8						
		V _{CC} = 1.65 V to 1.95 V	8.0	3.5	-	8.5	-	ns
		V _{CC} = 2.3 V to 2.7 V	5.0	2.1	-	5.5	-	ns
V _{CC} = 2.7 V	4.0	1.8	-	4.5	-	ns		
		V _{CC} = 3.0 V to 3.6 V	4.0	1.7	-	4.5	-	ns

Table 7. Dynamic characteristics ...continued

Voltages are referenced to GND (ground = 0 V). For test circuit see [Figure 13](#).

Symbol	Parameter	Conditions	–40 °C to +85 °C			–40 °C to +125 °C		Unit
			Min	Typ ^[1]	Max	Min	Max	
t _h	hold time	DS to SHCP; see Figure 9						
		V _{CC} = 1.65 V to 1.95 V	1.5	0.2	-	2.0	-	ns
		V _{CC} = 2.3 V to 2.7 V	1.5	0.1	-	2.0	-	ns
		V _{CC} = 2.7 V	1.5	–0.1	-	2.0	-	ns
t _{rec}	recovery time	M \bar{R} to SHCP; see Figure 11						
		V _{CC} = 1.65 V to 1.95 V	5.0	–2.7	-	5.5	-	ns
		V _{CC} = 2.3 V to 2.7 V	4.0	–1.5	-	4.5	-	ns
		V _{CC} = 2.7 V	2.0	–1.0	-	2.5	-	ns
f _{max}	maximum frequency	SHCP or STCP; see Figure 7 and Figure 8						
		V _{CC} = 1.65 V to 1.95 V	80	130	-	70	-	MHz
		V _{CC} = 2.3 V to 2.7 V	100	140	-	90	-	MHz
		V _{CC} = 2.7 V	110	150	-	100	-	MHz
t _{sk(o)}	output skew time	V _{CC} = 3.0 V to 3.6 V [5]	-	-	1.0	-	1.5	ns
		V _{CC} = 3.0 V to 3.6 V [6]						
		V _{CC} = 1.65 V to 1.95 V	-	50	-	-	-	pF
		V _{CC} = 2.3 V to 2.7 V	-	45	-	-	-	pF
C _{PD}	power dissipation capacitance	V _{CC} = 3.0 V to 3.6 V [6]	-	44	-	-	-	pF
		V _{CC} = 1.65 V to 1.95 V	-	50	-	-	-	pF
		V _{CC} = 2.3 V to 2.7 V	-	45	-	-	-	pF
		V _{CC} = 3.0 V to 3.6 V	-	44	-	-	-	pF

[1] Typical values are measured at T_{amb} = 25 °C and V_{CC} = 1.8 V, 2.5 V, 2.7 V, and 3.3 V respectively.

[2] t_{pd} is the same as t_{PLH} and t_{PHL}.

[3] t_{en} is the same as t_{PZH} and t_{PZL}.

[4] t_{dis} is the same as t_{PHZ} and t_{PLZ}.

[5] Skew between any two outputs of the same package switching in the same direction. This parameter is guaranteed by design.

[6] C_{PD} is used to determine the dynamic power dissipation (P_D in μW).

$$P_D = C_{PD} \times V_{CC}^2 \times f_i \times N + \sum(C_L \times V_{CC}^2 \times f_o) \text{ where:}$$

f_i = input frequency in MHz;

f_o = output frequency in MHz;

C_L = output load capacitance in pF;

V_{CC} = supply voltage in V;

N = number of inputs switching;

$\sum(C_L \times V_{CC}^2 \times f_o)$ = sum of outputs.

12. Waveforms

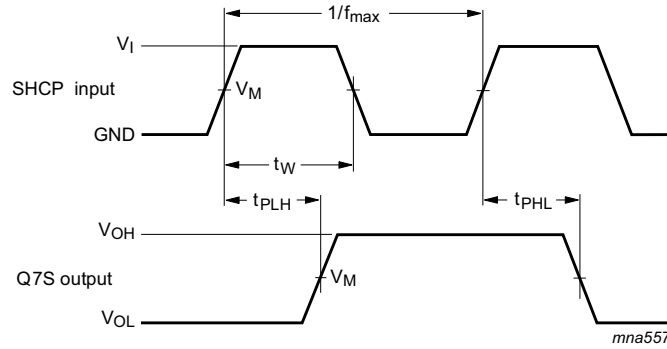

Measurement points are given in [Table 8](#).

V_{OL} and V_{OH} are typical output voltage drops that occur with the output load.

Fig 7. The shift clock (SHCP) to serial data output (Q7S) propagation delays, the shift clock pulse width and maximum shift clock frequency

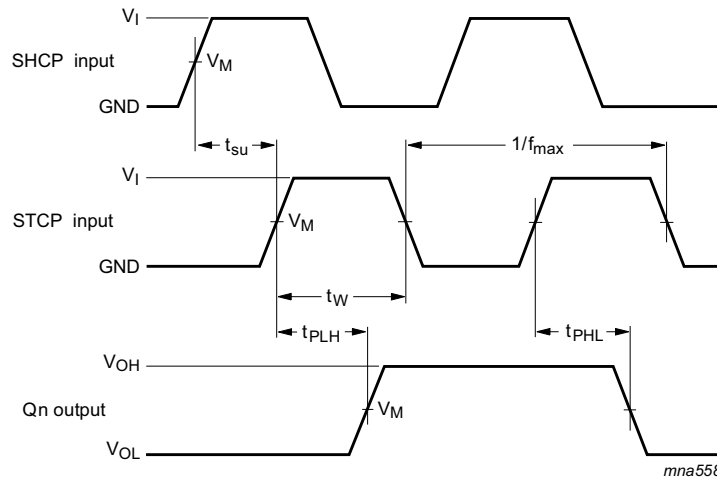

Measurement points are given in [Table 8](#).

V_{OL} and V_{OH} are typical output voltage drops that occur with the output load.

Fig 8. The storage clock (STCP) to parallel data output (Qn) propagation delays, the storage clock pulse width and the shift clock to storage clock set-up time

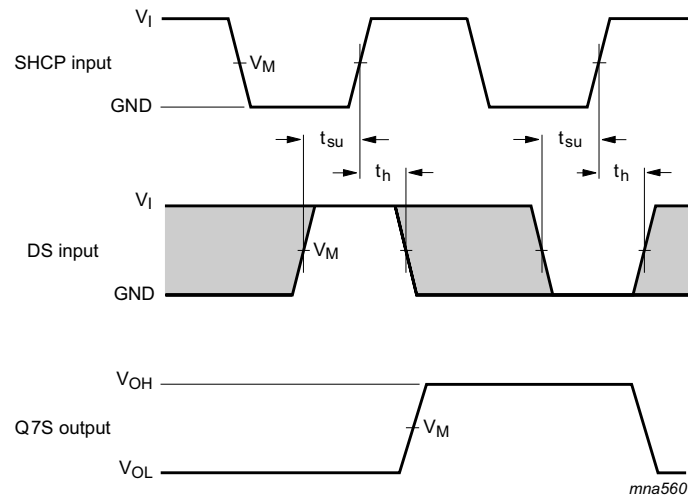

Measurement points are given in [Table 8](#).
 The shaded areas indicate when the input is permitted to change for predictable output performance.
 V_{OL} and V_{OH} are typical output voltage drops that occur with the output load.

Fig 9. The data set-up and hold times for the serial data input (DS)

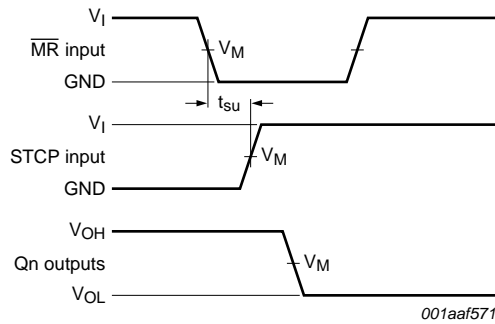

Measurement points are given in [Table 8](#).
 V_{OL} and V_{OH} are typical output voltage drops that occur with the output load.

Fig 10. The master reset (\overline{MR}) to storage clock (STCP) set-up times

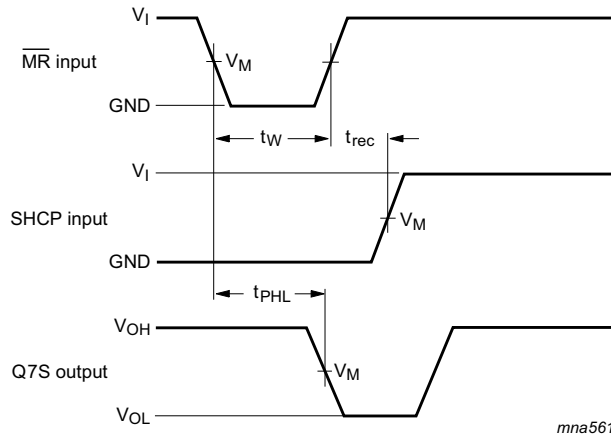

Measurement points are given in [Table 8](#).

V_{OL} and V_{OH} are typical output voltage drops that occur with the output load.

Fig 11. The master reset (MR) pulse width, the master reset to serial data output (Q7S) propagation delays and the master reset to shift clock (SHCP) recovery time

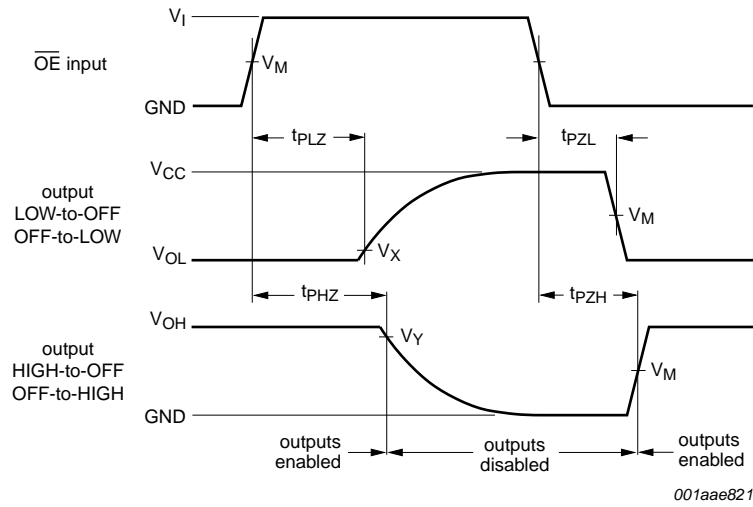

Measurement points are given in [Table 8](#).

V_{OL} and V_{OH} are typical output voltage drops that occur with the output load.

Fig 12. 3-state enable and disable times

Table 8. Measurement points

Supply voltage	Input	Output		
V_{CC}	V_M	V_M	V_X	V_Y
$V_{CC} < 2.7 V$	$0.5 \times V_{CC}$	$0.5 \times V_{CC}$	$V_{OL} + 0.15 V$	$V_{OH} - 0.15 V$
$V_{CC} \geq 2.7 V$	1.5 V	1.5 V	$V_{OL} + 0.3 V$	$V_{OH} - 0.3 V$

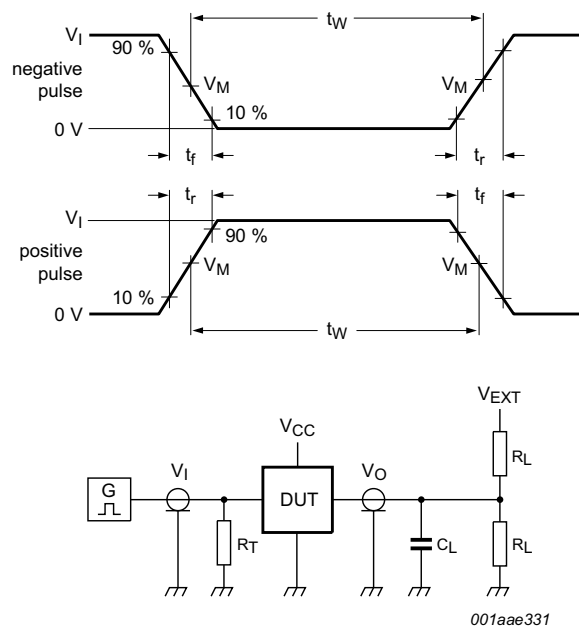

Test data is given in [Table 9](#). Definitions for test circuit:

R_L = Load resistance.

C_L = Load capacitance including jig and probe capacitance.

R_T = Termination resistance should be equal to output impedance Z_o of the pulse generator.

V_{EXT} = External voltage for measuring switching times.

Fig 13. Test circuit for measuring switching times

Table 9. Test data

Supply voltage	Input		Load		V_{EXT}		
	V_I	t_r, t_f	C_L	R_L	t_{PLH}, t_{PHL}	t_{PLZ}, t_{PZL}	t_{PHZ}, t_{PZH}
1.2 V	V_{CC}	≤ 2 ns	30 pF	1 k Ω	open	$2 \times V_{CC}$	GND
1.65 V to 1.95 V	V_{CC}	≤ 2 ns	30 pF	1 k Ω	open	$2 \times V_{CC}$	GND
2.3 V to 2.7 V	V_{CC}	≤ 2 ns	30 pF	500 Ω	open	$2 \times V_{CC}$	GND
2.7 V	2.7 V	≤ 2.5 ns	50 pF	500 Ω	open	$2 \times V_{CC}$	GND
3.0 V to 3.6 V	2.7 V	≤ 2.5 ns	50 pF	500 Ω	open	$2 \times V_{CC}$	GND

13. Package outline

SO16: plastic small outline package; 16 leads; body width 3.9 mm

SOT109-1

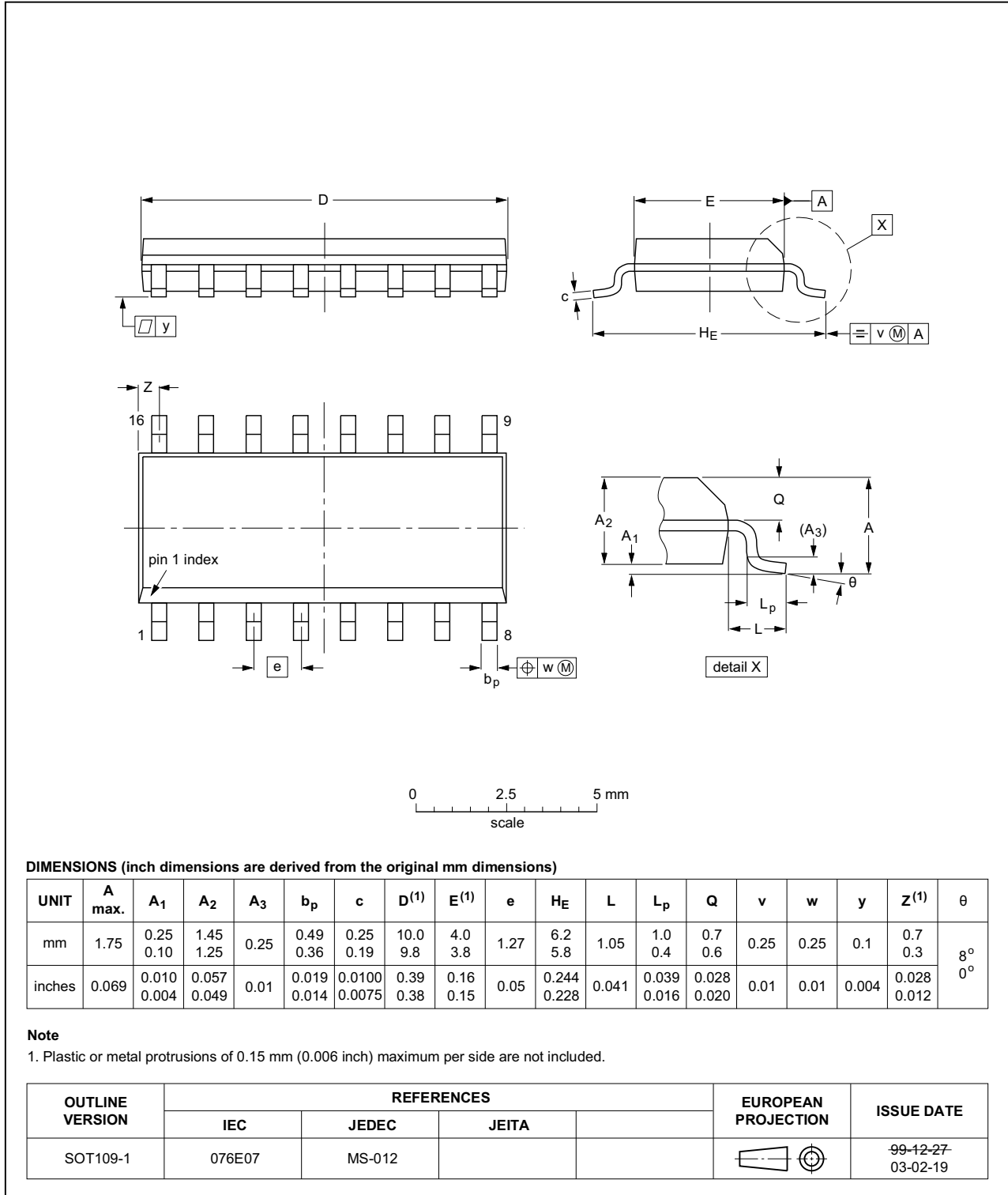

Fig 14. Package outline SOT109-1 (SO16)

TSSOP16: plastic thin shrink small outline package; 16 leads; body width 4.4 mm

SOT403-1

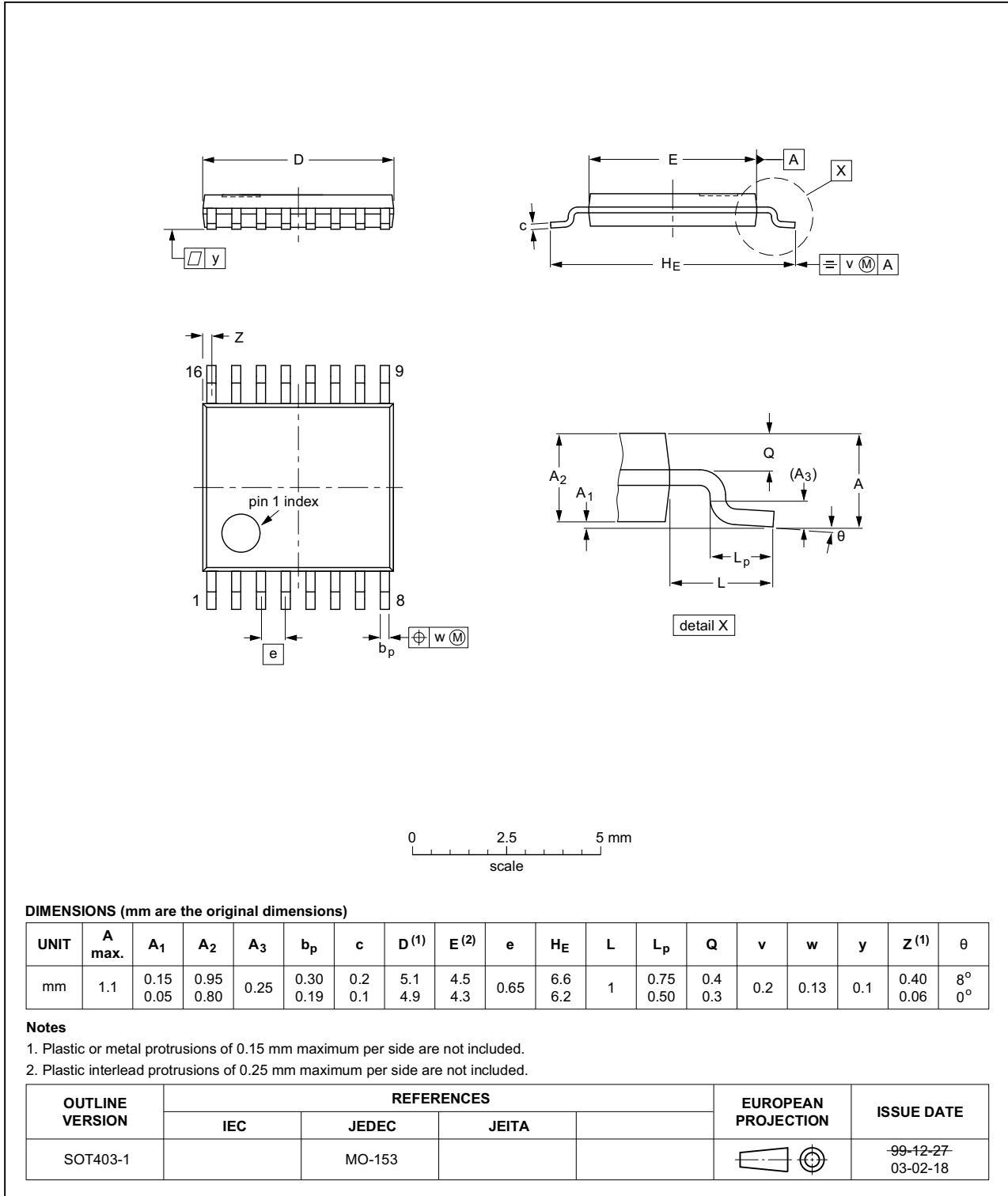

Fig 15. Package outline SOT403-1 (TSSOP16)

DHVQFN16: plastic dual in-line compatible thermal enhanced very thin quad flat package; no leads; 16 terminals; body 2.5 x 3.5 x 0.85 mm

SOT763-1

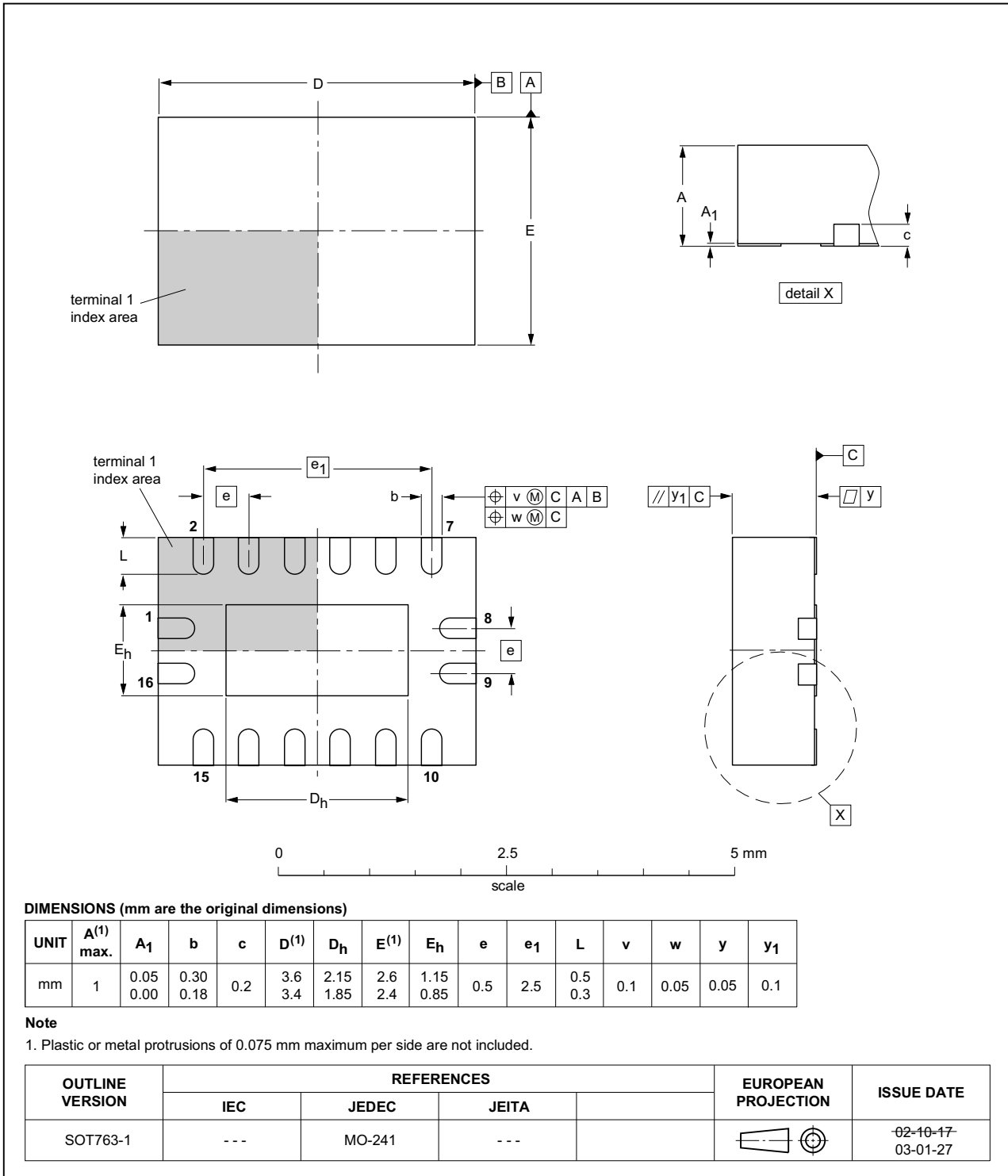

Fig 16. Package outline SOT763-1 (DHVQFN16)

14. Abbreviations

Table 10. Abbreviations

Acronym	Description
CDM	Charged Device Model
CMOS	Complementary Metal Oxide Semiconductor
DUT	Device Under Test
ESD	ElectroStatic Discharge
HBM	Human Body Model
TTL	Transistor-Transistor Logic

15. Revision history

Table 11. Revision history

Document ID	Release date	Data sheet status	Change notice	Supersedes
74LVC595A v.2	20140620	Product data sheet	-	74LVC595A v.1
Modifications:	<ul style="list-style-type: none">The format of this data sheet has been redesigned to comply with the new identity guidelines of NXP Semiconductors.Figure note for Figure 6 added.			
74LVC595A v.1	20070529	Product data sheet	-	-

16. Legal information

16.1 Data sheet status

Document status ^{[1][2]}	Product status ^[3]	Definition
Objective [short] data sheet	Development	This document contains data from the objective specification for product development.
Preliminary [short] data sheet	Qualification	This document contains data from the preliminary specification.
Product [short] data sheet	Production	This document contains the product specification.

[1] Please consult the most recently issued document before initiating or completing a design.

[2] The term 'short data sheet' is explained in section "Definitions".

[3] The product status of device(s) described in this document may have changed since this document was published and may differ in case of multiple devices. The latest product status information is available on the Internet at URL <http://www.nexperia.com>.

16.2 Definitions

Draft — The document is a draft version only. The content is still under internal review and subject to formal approval, which may result in modifications or additions. Nexperia does not give any representations or warranties as to the accuracy or completeness of information included herein and shall have no liability for the consequences of use of such information.

Short data sheet — A short data sheet is an extract from a full data sheet with the same product type number(s) and title. A short data sheet is intended for quick reference only and should not be relied upon to contain detailed and full information. For detailed and full information see the relevant full data sheet, which is available on request via the local Nexperia sales office. In case of any inconsistency or conflict with the short data sheet, the full data sheet shall prevail.

Product specification — The information and data provided in a Product data sheet shall define the specification of the product as agreed between Nexperia and its customer, unless Nexperia and customer have explicitly agreed otherwise in writing. In no event however, shall an agreement be valid in which the Nexperia product is deemed to offer functions and qualities beyond those described in the Product data sheet.

16.3 Disclaimers

Limited warranty and liability — Information in this document is believed to be accurate and reliable. However, Nexperia does not give any representations or warranties, expressed or implied, as to the accuracy or completeness of such information and shall have no liability for the consequences of use of such information. Nexperia takes no responsibility for the content in this document if provided by an information source outside of Nexperia.

In no event shall Nexperia be liable for any indirect, incidental, punitive, special or consequential damages (including - without limitation - lost profits, lost savings, business interruption, costs related to the removal or replacement of any products or rework charges) whether or not such damages are based on tort (including negligence), warranty, breach of contract or any other legal theory.

Notwithstanding any damages that customer might incur for any reason whatsoever, Nexperia's aggregate and cumulative liability towards customer for the products described herein shall be limited in accordance with the *Terms and conditions of commercial sale* of Nexperia.

Right to make changes — Nexperia reserves the right to make changes to information published in this document, including without limitation specifications and product descriptions, at any time and without notice. This document supersedes and replaces all information supplied prior to the publication hereof.

Suitability for use — Nexperia products are not designed, authorized or warranted to be suitable for use in life support, life-critical or safety-critical systems or equipment, nor in applications where failure or malfunction of a Nexperia product can reasonably be expected to result in personal injury, death or severe property or environmental damage. Nexperia and its suppliers accept no liability for inclusion and/or use of Nexperia products in such equipment or applications and therefore such inclusion and/or use is at the customer's own risk.

Applications — Applications that are described herein for any of these products are for illustrative purposes only. Nexperia makes no representation or warranty that such applications will be suitable for the specified use without further testing or modification.

Customers are responsible for the design and operation of their applications and products using Nexperia products, and Nexperia accepts no liability for any assistance with applications or customer product design. It is customer's sole responsibility to determine whether the Nexperia product is suitable and fit for the customer's applications and products planned, as well as for the planned application and use of customer's third party customer(s). Customers should provide appropriate design and operating safeguards to minimize the risks associated with their applications and products.

Nexperia does not accept any liability related to any default, damage, costs or problem which is based on any weakness or default in the customer's applications or products, or the application or use by customer's third party customer(s). Customer is responsible for doing all necessary testing for the customer's applications and products using Nexperia products in order to avoid a default of the applications and the products or of the application or use by customer's third party customer(s). Nexperia does not accept any liability in this respect.

Limiting values — Stress above one or more limiting values (as defined in the Absolute Maximum Ratings System of IEC 60134) will cause permanent damage to the device. Limiting values are stress ratings only and (proper) operation of the device at these or any other conditions above those given in the Recommended operating conditions section (if present) or the Characteristics sections of this document is not warranted. Constant or repeated exposure to limiting values will permanently and irreversibly affect the quality and reliability of the device.

Terms and conditions of commercial sale — Nexperia products are sold subject to the general terms and conditions of commercial sale, as published at <http://www.nexperia.com/profile/terms>, unless otherwise agreed in a valid written individual agreement. In case an individual agreement is concluded only the terms and conditions of the respective agreement shall apply. Nexperia hereby expressly objects to applying the customer's general terms and conditions with regard to the purchase of Nexperia products by customer.

No offer to sell or license — Nothing in this document may be interpreted or construed as an offer to sell products that is open for acceptance or the grant, conveyance or implication of any license under any copyrights, patents or other industrial or intellectual property rights.

Export control — This document as well as the item(s) described herein may be subject to export control regulations. Export might require a prior authorization from competent authorities.

Non-automotive qualified products — Unless this data sheet expressly states that this specific Nexperia product is automotive qualified, the product is not suitable for automotive use. It is neither qualified nor tested in accordance with automotive testing or application requirements. Nexperia accepts no liability for inclusion and/or use of non-automotive qualified products in automotive equipment or applications.

In the event that customer uses the product for design-in and use in automotive applications to automotive specifications and standards, customer (a) shall use the product without Nexperia's warranty of the product for such automotive applications, use and specifications, and (b) whenever customer uses the product for automotive applications beyond

Nexperia's specifications such use shall be solely at customer's own risk, and (c) customer fully indemnifies Nexperia for any liability, damages or failed product claims resulting from customer design and use of the product for automotive applications beyond Nexperia's standard warranty and Nexperia's product specifications.

Translations — A non-English (translated) version of a document is for reference only. The English version shall prevail in case of any discrepancy between the translated and English versions.

16.4 Trademarks

Notice: All referenced brands, product names, service names and trademarks are the property of their respective owners.

17. Contact information

For more information, please visit: <http://www.nexperia.com>

For sales office addresses, please send an email to: salesaddresses@nexperia.com

18. Contents

1	General description	1
2	Features and benefits	1
3	Applications	1
4	Ordering information	2
5	Functional diagram	2
6	Pinning information	4
6.1	Pinning	4
6.2	Pin description	4
7	Functional description	5
8	Limiting values	5
9	Recommended operating conditions	6
10	Static characteristics	6
11	Dynamic characteristics	7
12	Waveforms	10
13	Package outline	14
14	Abbreviations	17
15	Revision history	17
16	Legal information	18
16.1	Data sheet status	18
16.2	Definitions	18
16.3	Disclaimers	18
16.4	Trademarks	19
17	Contact information	19
18	Contents	20